



850nm 400mW VCSEL Diode in 3535 Package

Part No.VC35A-850H400A (Substrate AlN) | VC35C-850H400A (Substrate CuAg)

Features

- 3535 package
- Good thermal conduction
- Oxide isolation technology
- Low threshold current
- High reliability and easy to collimate
- 400mW 850nm VCSEL @ 780mA

Applications

- Lidar
- IR illumination
- 3D sensor
- Machine vision
- Medical application

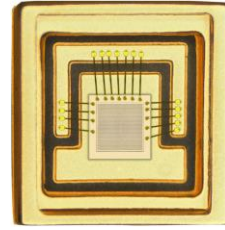

Substrate AlN, 3535 Package



Substrate CuAg, 3535 Package

Specifications

Absolute Maximum Ratings					
Parameters	Symbol	Rating	Unit	Conditions	
Case Operating Temperature	Top	-40 to 85	°C		
Storage Temperature	Tstg	-40 to 105	°C		
Reflow Soldering Temperature	Tsol	260	°C	10 seconds	
Reverse Voltage	Vr	5	V		
Maximum Continuous Current	I _{max}	1.5	A		
ESD Exposure (Human Body) Model	ESD	2K	V		

Notes:

- Stresses greater than those listed under “Absolute Maximum Ratings” may cause permanent damage to the device. This is a stress rating only and functional operation of the device at these or other conditions above those indicated in the operations section for expanded periods of time may affect reliability.
- In its maximum rating diode laser operation could damage its performance or cause potential safety hazard such as equipment failure.
- Electrostatic discharge is the main reason for laser fault of the diode. Take effective precautions against ESD. When dealing with laser diodes, use wrist strap, grounding work surface and strict antistatic technology.

Electro-Optical Characteristics (T _{op} =25°C, CW mode)						
Parameters	Symbol	Min.	Typ.	Max.	Unit	Conditions
Optical Output Power	P _o	-	400	-	mW	I _F =780mA
Threshold Current	I _{th}	-	90	-	mA	
Forward current	I _F	-	780	-	mA	
Slope Efficiency	η	-	0.64	-	mW/mA	P _o =400mW
Power Conversion Efficiency	PCE	-	23	-	%	I _F =780mA
Peak Wavelength	λ _P	840	850	860	nm	I _F =780mA
Laser Forward Voltage	V _F	-	2.25	-	V	I _F =780mA
Series Resistance	R _S	-	0.63	-	Ohm	I _F =780mA
Beam Angle	Θ	-	24	-	Deg	I _F =780mA
Wavelength Temperature Drift	Δλ _P / ΔT	-	0.07	-	nm/°C	I _F =780mA
Soldering Temperature	Tsol			260	°C	10 seconds
Substrate						AlN; CuAg

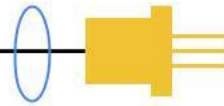

Typical Characteristics

LIV Graph

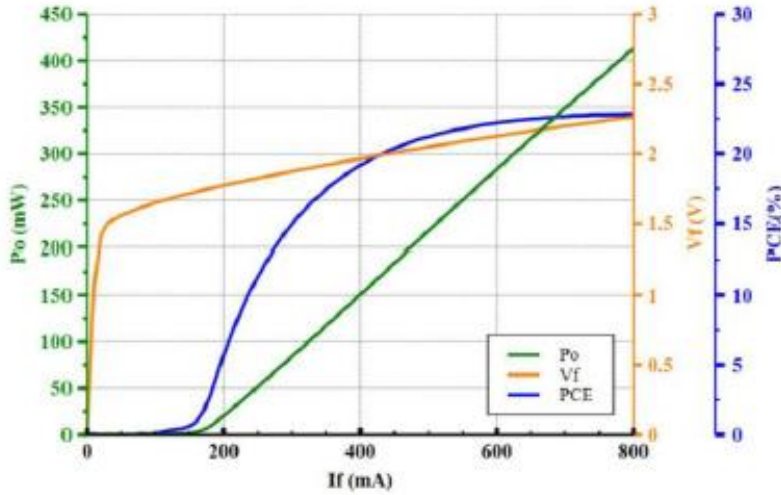

Intensity vs. Wavelength

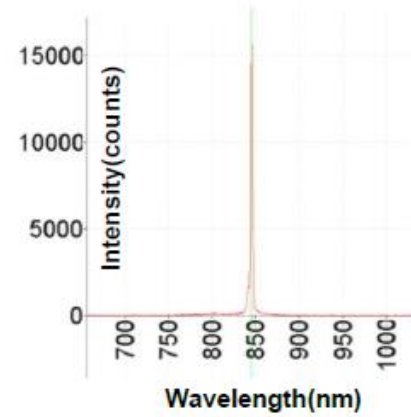

Outline Dimensions (unit: mm)

Substrate AlN, Package 3535

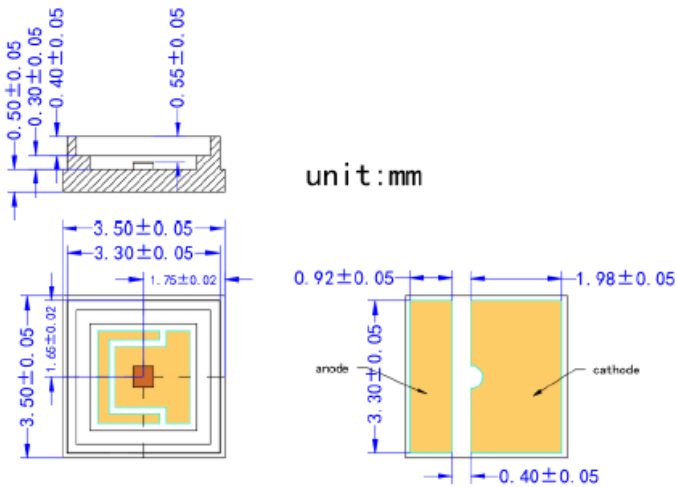

Substrate CuAg, Package 3535

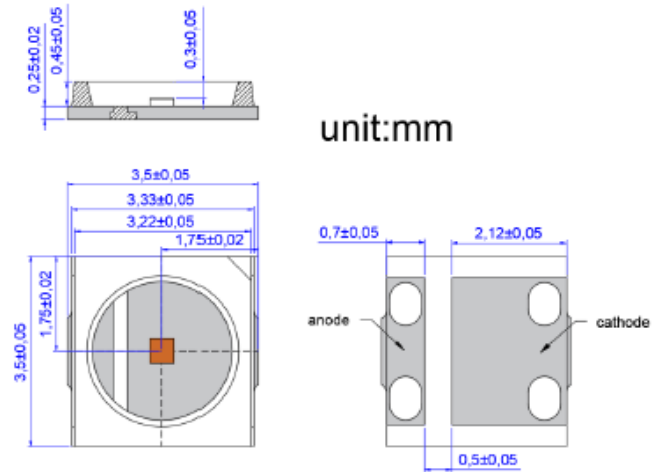

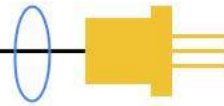

SMT Reflow Soldering Curve

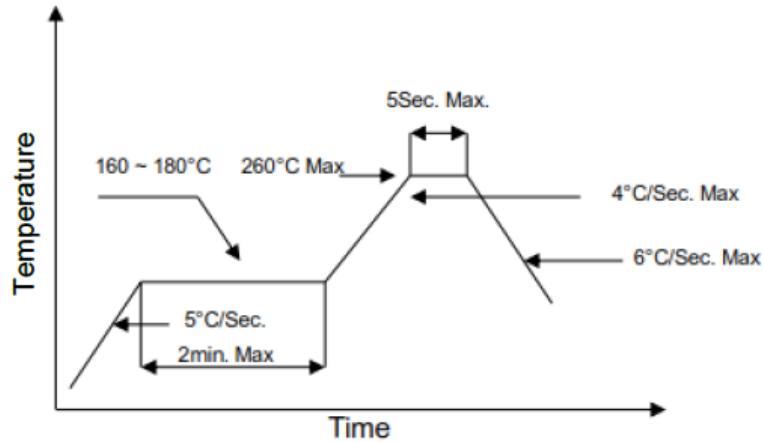

Note: Reflow soldering can be operated only one time. During the temperature ramp-up, no forces may be exerted on the LD which would deform or damage them. After soldering is completed, please do not process until the product temperature ramps down to room temperature.

Additional Notes

1. Please use solder paste to cure the laser diode.
2. Please make sure that the heat of VCSEL diode has been completely conducted to metal shell to avoid affecting the optical power output.
3. This VCSEL diode can be only used in constant voltage and current.
4. Please do not aim the laser at people or animals.
5. You may observe the laser spot through an image monitoring equipment.
6. Please do not touch VCSEL diode surface by naked hands or squeeze the sealant on VCSEL diode surface. It may cause wrong optical angle and distorted laser spot, and even damage the VCSEL diode.
7. Please use ceramic suction nozzle to absorb the VCSEL diode, so as to avoid VCSEL diode sticking to the nozzle.
8. Please add a 0.02s blowing action after locating the laser diode to aluminum substrate.
9. Specifications are subject to change without notice.