

125Mbps 1310nm Multimode 2km SGMII SFP Optical Transceiver with Duplex LC Connector

Model No. SGMII-125MF-3C-TI-L

DESCRIPTION

The 100BASE-FX Small Form-Factor Pluggable (SFP) Fast Ethernet interface transceiver is a hot swappable device that plugs into a Gigabit Ethernet SFP port. This SGMII SFP transceiver built-in PHY chip provides full-duplex 100-Mbps connectivity between switches over multimode fiber (MMF) or single mode fiber (SMF) infrastructures. The host equipment can access this information via the 2-wire serial CMOS EEPROM protocol. For further information, please refer to SFP Multi-Source Agreement (MSA). To meet the increasing demand of Industrial Ethernet fiber solution, SGMII SFP transceiver series can operate reliably in electrically harsh, climatically demanding, and wide temperature range (-40°C to 85°C) environment.

FEATURES

- Built-in PHY and MCU supporting SGMII Interface
- 125Mbps IEEE 802.3u 100BASE-FX compliant
- Standard serial ID information
- Compatible with SFP MSA
- AC-coupled differential inputs and outputs
- 2km link on a multimode fiber and 10km/40km on a single mode fiber
- SFF8472 diagnostic monitoring interface
- LC type pluggable optical interface
- Fully metallic enclosure for low EMI
- +3.3V single power supply
- Operating case temperature: -40 to +85°C



APPLICATIONS

- 125 Mbps 100Base-FX Ethernet / FDDI
- Switch to Switch interface
- Switched backplane applications
- Switch/Router to Switch/Router Link
- Other optical transmission systems

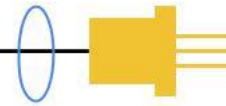
**ABSOLUTE MAXIMUM RATINGS**

PARAMETER	SYMBOL	MIN	MAX	UNIT	NOTES
Case Operating Temperature	T_c	-40	85	°C	
Storage Temperature	T_s	-40	85	°C	
Supply Voltage	V_{CC}	3.0	3.65	V	
Storage Humidity	H_s	5	+95	%	Non-condensing

RECOMMENDED OPERATING CONDITIONS

PARAMETER	SYMBOL	MIN	TYP	MAX	UNIT	NOTES
Case Operating Temperature	T_c	-40	-	85	°C	
Operating Humidity	H_o	10	-	85	%	
Power Supply Voltage	V_{CC}	3.14	3.30	3.47	V	
Power Supply Current	I_{CC}	-	-	350	mA	Max power supply current after module work stable.
Data Rate	D_R	-	125	-	Mbps	

TRANSMITTER ELECTRO-OPTICAL CHARACTERISTICS

PARAMETER	SYMBOL	MIN	TYP.	MAX	UNIT	NOTES
Output Optical Power 62.5/125 μ m fiber	P_{out}	-20	-	-14	dBm	
Output Optical Power 50/125 μ m fiber	P_{out}	-23.5	-	-14	dBm	
Center Wavelength	λ_c	1260	-	1380	nm	
Spectral Width (FWHM)	FWHM	-	-	100	nm	
Extinction Ratio	ER	10	-	-	dB	
Rise/Fall Time (10~90%)	T_r/T_f	-	-	3	ns	
Output Optical Eye	Compliant with ITU-T recommendation G-957					
Data Input Differential Voltage	$V_{D,TX}$	0.25	-	1.20	V	Internally AC coupled and terminated to 100 Ohm differential load.
Differential Input Impedance	Z_{TX}	80	100	120	ohm	
Transmitter Disable Input-High	V_{DISH}	2.0	-	$V_{CC}+0.3$	V	
Transmitter Disable Input-Low	V_{DISL}	0	-	0.8	V	

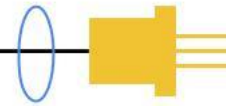

RECEIVER ELECTRO-OPTICAL CHARACTERISTICS

PARAMETER	SYMBOL	MIN	TYP.	MAX	UNIT	NOTES
Center Wavelength	λ_c	1260	-	1380	nm	
Optical Input Power-Maximum	P_{IN}	-8	-	-	dBm	Measured with 4B/5B code for 100Mbps, worst-case extinction ratio, $BER \leq 10^{-10}$
Optical Input Power-Sensitivity	P_{IN}	-	-	-31	dBm	Measured with 4B/5B code for 100Mbps, worst-case extinction ratio, $BER \leq 10^{-10}$
LOS-Deasserted	P_D	-	-	-31	dBm	
LOS-Asserted	P_A	-45	-	-	dBm	
Receiver Loss of Signal Output Voltage-Low	RX_LOS_L	0	-	0.5	V	
Receiver Loss of Signal Output Voltage-High	RX_LOS_H	2.4	-	Vcc	V	
Data Output Differential Voltage	$V_{D,RX}$	0.35	-	0.8	V	Internally AC coupled, but requires a 100 Ohm differential termination at MAC side
Differential Output Impedance	Z_{RX}	80	100	120	ohm	
Data Output Rise/Fall Time	$T_{r,RX}/T_{f,RX}$	-	175	-	ps	20%-80% values
LOS Output Voltage-High	V_{SDHL}	Vcc-0.5	-	Vcc+0.3	V	Pull up to Vcc with a 4.7K-10K Ohm resistor on host board.
LOS Output Voltage-Low	V_{SDL}	0	-	0.8	V	Pull up to Vcc with a 4.7K-10K Ohm resistor on host board.

RECOMMENDED HOST BOARD POWER SUPPLY CIRCUIT

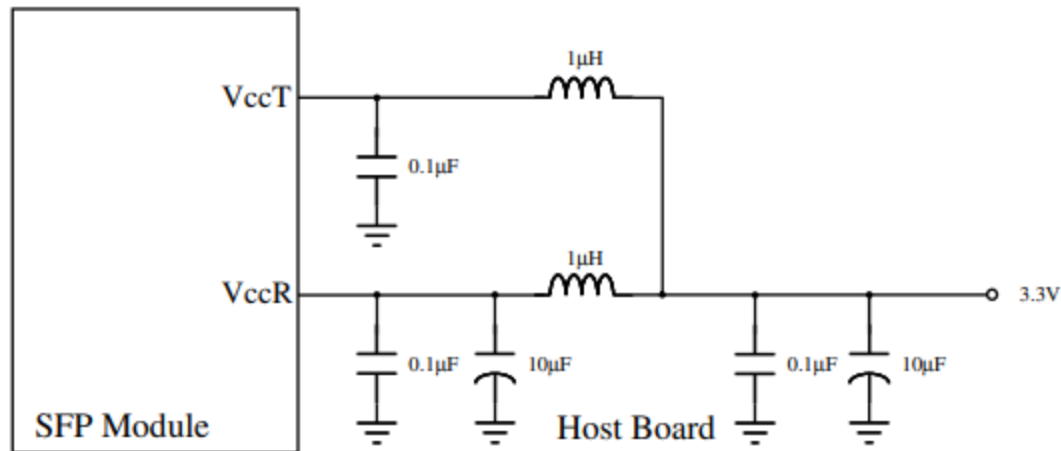

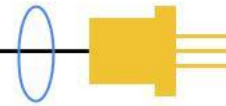

RECOMMENDED INTERFACE CIRCUIT

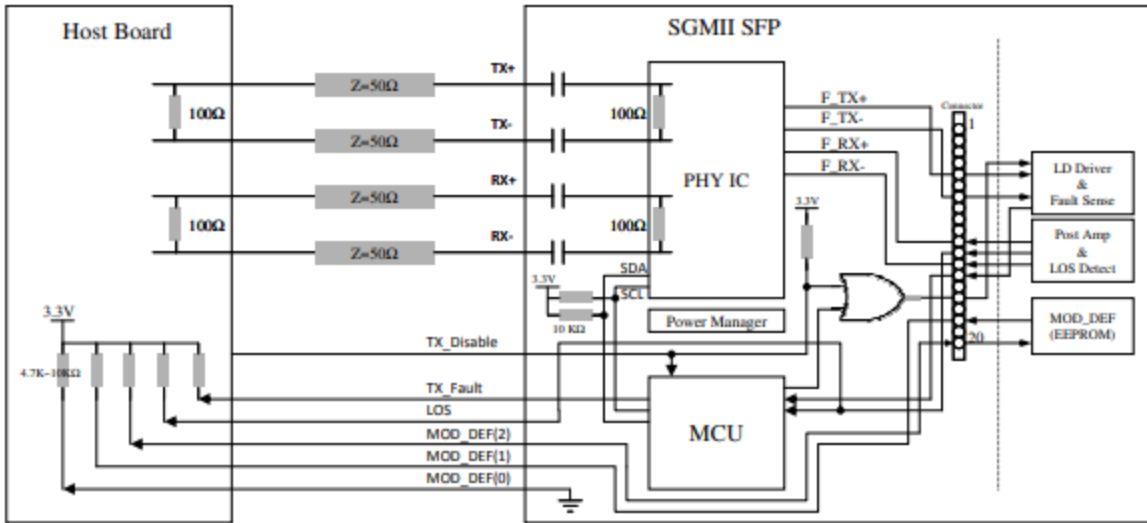

TX_DISABLE Function

There are active components in the SFP Transceiver as PHY and MCU so it takes some time to start up MCU and initialize the active PHY. The communication path of the SFP is ready after 20ms. The TX_DISABLE signal is high (TTL logic “1”) to turn off the laser output. The laser will turn on when TX_DISABLE is low (TTL logic “0”).

LOS Function

The SFP MSA specification defines a pin called LOS to indicate loss of signal to the motherboard. This should be pulled up with a 4.7K to 10K resistor. Pull up voltage between 2.0V and Vcc-T/R+0.3V. When high, this output indicates link fail. Low indicates normal operation. In the low state, the output will be pulled to <0.8V.

Termination Circuits

Inputs to the transceiver are AC coupled and internally terminated through 50 ohms. These modules can operate with PECL or ECL logic levels. The input signal must have at least a 250mV peak-to-peak (single ended) signal swing. Output from the receiver section of the module is also AC coupled and is expected to drive a 50-ohm load. Different termination strategies may be required depending on the particular Serializer/Deserializer chip set used.

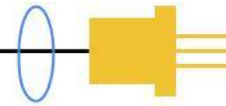

EEPROM SECTION

The Smart SFP support the 2-wire serial communication protocol defined in the SFP MSA. These SFP use a 128-byte EEPROM with an address of A0H. Accessing Serial ID Memory uses the 2 wire address 10100000 (A0H). Memory Contents of Serial ID are shown in Table 1.

Table 1 Serial ID Memory Contents

Addr.	Size (Bytes)	Name of Field	Hex	Description
0	1	identifier	03	SFP or SFP+
1	1	Ext.Identifier	04	GBIC/SFP function is defined by two-wire interface ID only
2	1	Connector	07	LC
3-10	8	Transceiver	00 00 00 08 00 00 00 00	Transceiver Code
11	1	Encoding	02	4B/5B
12	1	BR(Nominal)	01	125Mbps
13	1	Rate Identifier	00	Unspecified
14	1	Length(SMFm)-km	00	N/A
15	1	Length(SMF)	00	N/A
16	1	Length(50µm)	C8	2Km
17	1	Length(62.5µm)	C8	2Km
18	1	Length(cable)	00	N/A
19	1	Length(OM3)	00	N/A
20-35	16	Vendor name	XX XX XX XX XX XX XX 20 20 20 20 20 20 20 20 20	Vendor name (ASCII)
36	1	Transceiver	00	Unallocated
37-39	3	Vendor OUI	XX XX XX	Vendor OUI
40-55	16	Vendor PN	XX XX XX XX XX XX XX XX XX XX XX XX XX XX XX XX XX XX	Transceiver part number
56-59	4	Vendor rev	XX XX XX XX	Vendor rev
60-61	2	Wavelength	05 1E	1310nm
62	1	Unallocated	00	Unallocated
63	1	CC_BASE	Check Sum (Variable)	Check code for Base ID Fields
64-65	2	Options	00 1A	LOS, TX_FALUT, and TX_DISABLE
66	1	BR	00	max
67	1	BR	00	min
68-83	16	Vendor SN	41 34 32 30 33 30 30 34 20 20 20 20 20 20 20 20	Serial Number of transceiver (ASCII). For example "A4203004".
84-91	8	Date code	XX XX XX XX XX XX XX XX	Manufacture date code
92	1	Diagnostic Monitoring Type	68	N/A
93	1	Enhanced Options	B0	N/A
94	1	SFF-8472 Compliance	02	Digital diagnostic function not included or undefined
95	1	CC_EXT	Check Sum (Variable)	Check sum for Extended ID Field.
96-127	32	Vendor Specific	Read only	Depends on customer information

Note: The "XX" byte should be filled in according to practical case. For more information, please refer to the related document of SFP Multi-Source Agreement (MSA).

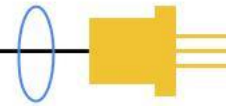

The SGMII SFP transceiver provides diagnostic information about the present operating conditions. This transceiver generates this diagnostic data by digitization of internal analog signals. Calibration and alarm/warning threshold data is written during device manufacture. Received power monitoring, transmitted power monitoring, bias current monitoring, supply voltage monitoring and temperature monitoring all are implemented. The diagnostic data are raw A/D values and must be converted to real world units using calibration constants stored in EEPROM locations 56 – 95 at wire serial bus address A2h. The digital diagnostic memory map specific data field defined as following.

2 wire address 1010000X (A0h)

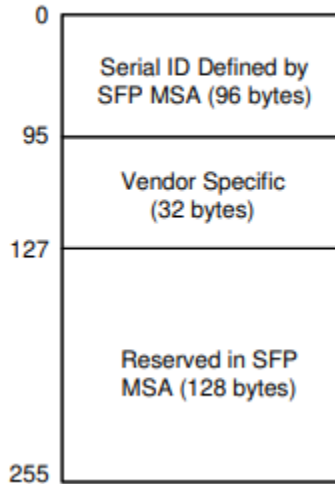

2 wire address 1010001X (A2h)

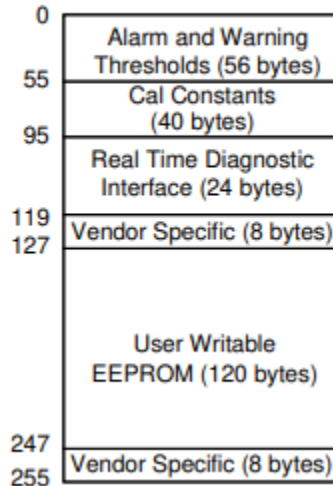

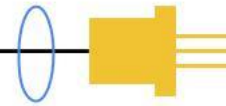

SFP PIN DEFINITIONS

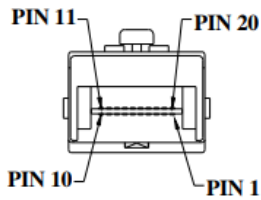

Pin	Signal Name	Function	NOTES
1	VeeT	Transmitter Ground	VeeT and VeeR are connected in SFP.
2	TX_FAULT	Transmitter Fault Indication	Transmit Fault
3	TX_DISABLE	Transmitter Disable	Connected to PHY reset
4	MOD DEF (2)	Module Definition 2	Data Line for Serial ID (SDA).
5	MOD DEF (1)	Module Definition 1	Clock Line for Serial ID (SCL).
6	MOD DEF (0)	Module Definition 0	Tied to Vee in SFP.
7	RATE SELECT	Not Implemented	Not implemented.
8	LOS	Loss of Signal	See LOS option.
9	VeeR	Receiver Ground	VeeT and VeeR are connected in SFP.
10	VeeR	Receiver Ground	VeeT and VeeR are connected in SFP.
11	VeeR	Receiver Ground	VeeT and VeeR are connected in SFP.
12	RD-	Inverted Received Data out	AC coupled 100 ohm differential high speed data lines.
13	RD+	Non-Inverted Received Data out	AC coupled 100 ohm differential high speed data lines.
14	VeeR	Receiver Ground	VeeT and VeeR are connected in SFP.
15	VccR	Receiver Power	VccR and VccT are connected in SFP.
16	VccT	Transmitter Power	VccR and VccT are connected in SFP.
17	VeeT	Transmitter Ground	VeeT and VeeR are connected in SFP.
18	TD+	Non-inverted Data In	AC coupled 100 ohm differential high speed data lines.
19	TD-	Inverted Data In	AC coupled 100ohm differential high speed data lines
20	VeeT	Transmitter Ground	Veet and VeeR are connected in SFP

Notes:

1. TX Fault is an open collector output, which should be pulled up with a 4.7k-10kΩ resistor on the host board to a voltage between 2.0V and Vcc+0.3V. Logic 0 indicates normal operation; Logic 1 indicates a laser fault of some kind. In the low state, the output will be pulled to less than 0.8V.
2. TX Disable as described in the MSA is connected to PHY reset and optical module for the 100BASE-FX application.
3. Mod-Def 0, 1, 2 are the module definition pins. They should be pulled up with a 4.7k-10kΩ resistor on the host board to a supply less than VccT + 0.3 V or VccR + 0.3 V.
4. RD-/+: These are the differential receiver outputs. They are ac coupled 100Ω differential lines which should be terminated with 100Ω differentials. The ac coupling is done inside the module and is thus not

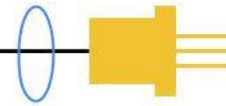

required on the host board. The voltage swing levels are compatible with CML and LVPECL voltage swings.

5. VccR and VccT are the receiver and transmitter power supplies. They are defined as $3.3V \pm 5\%$ at the SFP connector pin.
6. TD-/+ : These are the differential transmitter inputs. They are ac coupled differential lines with 100Ω differential terminations inside the module. The ac coupling is done inside the module and is thus not required on the host board. The inputs levels are compatible with CML and LVPECL voltage swings.

DRAWING DIMENSIONS

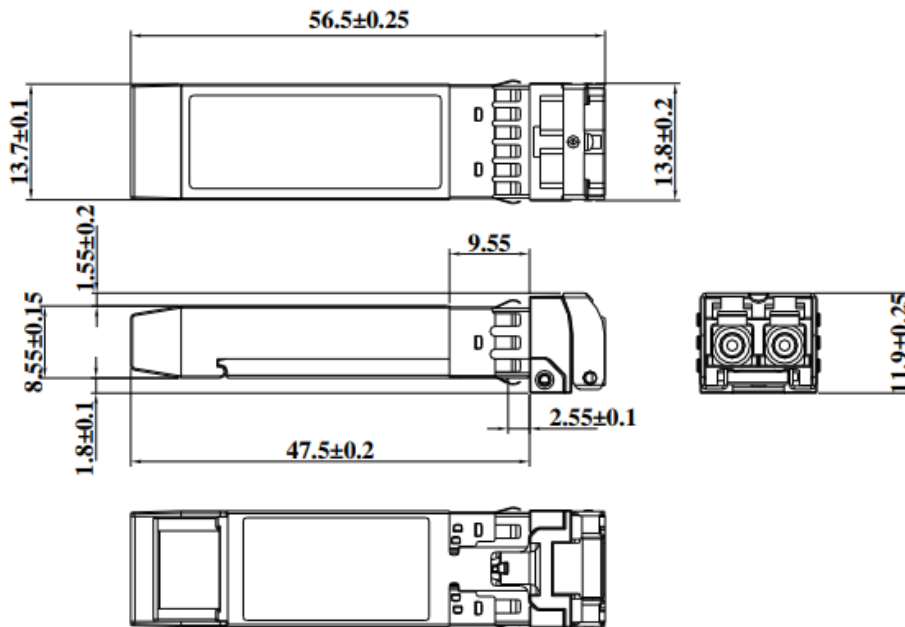

Unit : mm

ADDITIONAL NOTES

- [Warning] Laser Safety: Radiation emitted by laser devices can be dangerous to human eyes. Avoid eye exposure to direct or indirect radiation.
- The specifications subject to change without notice.