



QSLF355 Series 355nm Passively Q-Switched Laser System up to 10μJ

Overview

The QSLF355 series diode pumped solid state (DPSS) Q-switched UV laser is ideal for applications that require a wavelength of 355nm and single pulse energy levels up to 10uJ. The laser features a compact design, long lifetime, easy operation, and FDA-compliant system with driver. The laser is widely used in UV curing, microelectronics, CD carving, laser medical treatment, scientific experiment, and many other applications.



Specifications

Model Number		QSLF355-XYPR
Wavelength (nm)		355±1
Operating mode		Frequency conversion of Q-switched pulsed laser
Single pulse energy (μJ)		~1 (X=1), ~3 (X=3), ~5 (X=5), ~10 (X=10)
Average power stability (rms, over 4 hours)		<10% (P=B), <5% (P=A)
Pulse duration (ns)		~5
Peak power (W)		Peak Power (W) = Single Pulse Energy (μJ) / Pulse Duration (μs)
Repetition rate (kHz)	Fixed	One fixed rep. rate internal between 1kHz-4kHz, such as 1kHz (R=S1), 2kHz (R=S2), 3kHz (R=S3) and 4kHz (R=S4) with stable pulse energy, pulse duration and pulse period.
	External Trigger	Rep. rate in the range of 1kHz-4kHz obtained by external trigger with stable pulse energy, pulse duration and pulse period. (R=C)
	QCW	QCW state with one rep. rate between 5kHz-10kHz. (R=U)
Average power (mW)		Average power (mW) = Single pulse energy (μJ) * Rep. rate (kHz)
Transverse mode		Near TEM ₀₀
Beam divergence, full angle (mrad)		<1.5
Beam diameter at aperture (mm)		~2.0
M ² factor		<1.5
Spectral purity		>99%
Polarization ratio		>100:1
Warm-up time (minutes)		<10
Pointing stability after warm-up (mrad)		<0.05
Beam height from base plate (mm)		45
Operating temperature (°C)		10-35
Dimensions of laser head (mm)		211(L)x88(W) x74(H) mm ³
Weight of laser head (kg)		1.6 kg
Power supply		
High Power Elite Power Supply (Y=H)	Input voltage	90-264VAC
	Dimensions	236(L) x145(W) x104(H) mm ³
	Weight	2.3 kg
	Notes	CW mode with complete FDA compliant features, such as the turnkey switch and interlock, and easy to operate
Expected lifetime (hours)		5,000
Warranty period		10 months
FDA Compliance		FDA CDRH Title 21 CFR 1040.10/11 Class IV

Remarks:

- Due to the Walk-off effect of nonlinear crystals, the beam quality of the UV laser is not as good as that of the 1064/532nm laser.
- Specifications of the Q-switched pulsed laser is based on the laser pulsed at the specified repetition rate. If the laser is run at a different repetition rate, the output characteristics may change.
- Specifications are subject to change without notice.



Outline Dimensions (unit: mm)

Laser Head

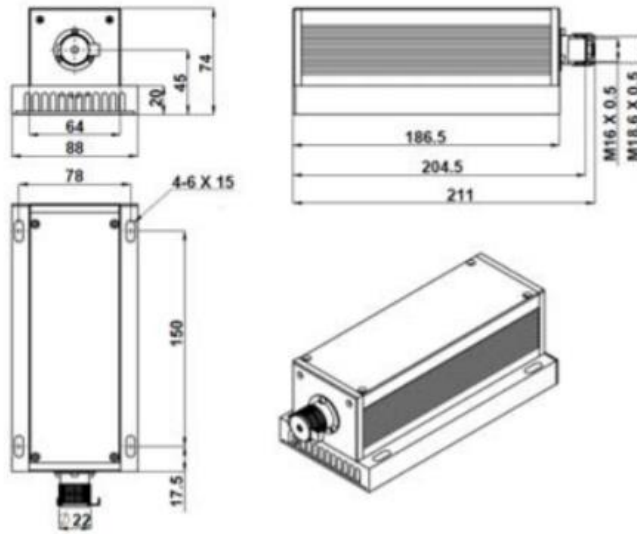

Power Supply

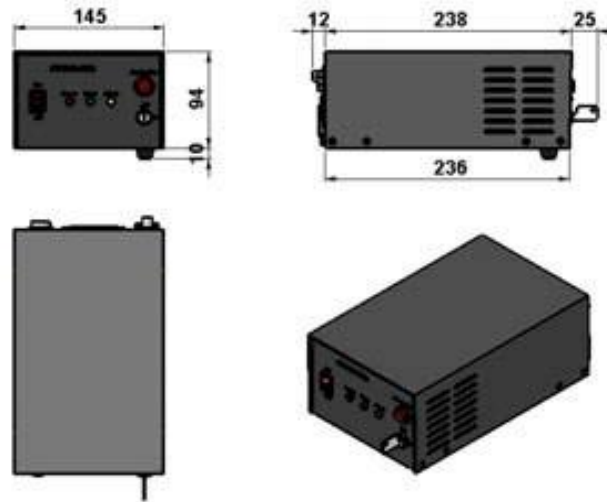

Note: The above specifications are subject to change without notice.