



## QSLF349 Series 349nm Passively Q-Switched Laser System up to 30mW

### Overview

The QSLF349 series diode pumped solid state (DPSS) Q-switched UV laser is ideal for applications that require a wavelength of 349nm and average output power up to 30mW. The laser is constructed with features of FDA compliance, ultra-compactness, long lifetime, easy operation, and cost effectiveness. The laser is widely used in UV curing, microelectronics, CD carving, laser medical treatment, scientific experiment, and many other applications.



### Specifications

<b>Model Number</b>		<b>QSLF349-XYPR</b>
Wavelength (nm)		349±1
Operating mode		Frequency conversion of Q-switched pulsed laser
Transverse mode		Near TEM <sub>00</sub>
Output average power (mW)		~5 ( <b>X=5</b> ), ~10 ( <b>X=10</b> ), ~20 ( <b>X=20</b> ), ~30 ( <b>X=30</b> )
Single pulse energy (µJ)		Single pulse energy (µJ) = Average power (mW) / Rep. rate (kHz)
Average power stability (rms, over 4 hours)		<10% ( <b>P=B</b> ), <5% ( <b>P=A</b> )
Pulse duration (ns)		~4
Peak power (W)		Peak Power (W) = Single Pulse Energy (µJ) / Pulse Duration (µs)
Repetition rate (kHz)	Fixed	One fixed rep. rate internal between 0.1Hz-1kHz, such as 0.1Hz ( <b>R=S1</b> ), 100Hz ( <b>R=S2</b> ), 500Hz ( <b>R=S3</b> ) and 1kHz ( <b>R=S4</b> ) with stable pulse energy, pulse duration and pulse period.
	External Trigger	Rep. rate in the range of 0.1Hz-1kHz obtained by external trigger with stable pulse energy, pulse duration and pulse period. ( <b>R=C</b> )
	QCW	QCW state with one rep. rate between 2kHz-3kHz. ( <b>R=U</b> )
Average power (mW)		Average power (mW) = Single pulse energy (µJ) * Rep. rate (kHz)
Beam divergence, full angle (mrad)		<1.5
Beam diameter at aperture (mm)		~2.0
Polarization ratio		>50:1
Pointing stability after warm-up (mrad)		<0.05
Warm-up time (minutes)		<10
Beam height from base plate (mm)		45
Spectral purity		>99%
Operating temperature (°C)		10~35
Dimensions of laser head (mm)		211(L)×88(W) ×74(H) mm <sup>3</sup>
Weight of laser head (kg)		1.6 kg
Power supply		
High Power Elite Power Supply ( <b>Y=H</b> )	Input voltage	90-264VAC
	Dimensions	236(L) ×145(W) ×104(H) mm <sup>3</sup>
	Weight	2.3 kg
	Notes	CW mode with complete FDA compliant features, such as the turnkey switch and interlock, and easy to operate
Expected lifetime (hours)		5,000
Warranty period		10 months
FDA Compliance		FDA CDRH Title 21 CFR 1040.10/11 Class IV

#### Remarks:

- Due to the Walk-off effect of nonlinear crystals, the beam quality of the UV laser is not as good as that of the 1047/532nm laser.
- Specifications of the Q-switched pulsed laser is based on the laser pulsed at the specified repetition rate. If the laser is run at a different repetition rate, the output characteristics may change.

**Lasermate Group, Inc.**

19608 Camino De Rosa, Walnut, CA 91789, USA

Tel: (909)718-0999 | Fax: (909)718-0998 | E-mail: info@lasermate.com | URL: <http://www.lasermate.com>



**Outline Dimensions (unit: mm)**

**Laser Head**

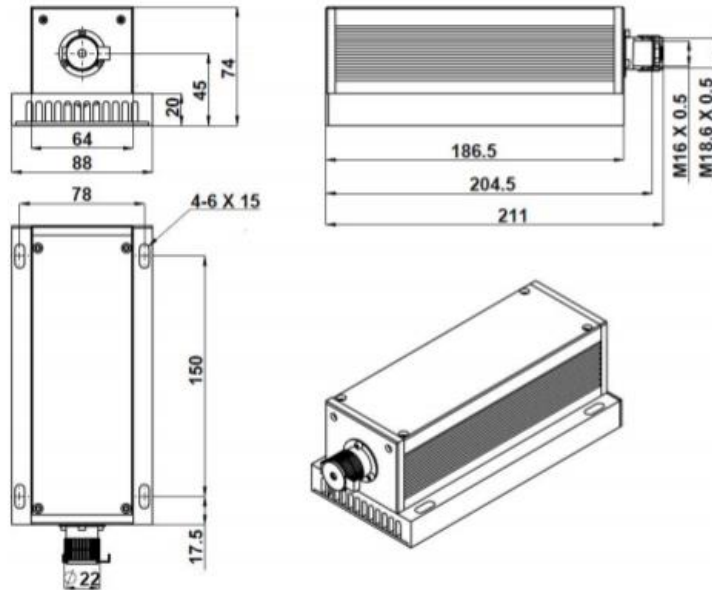

**Power Supply**

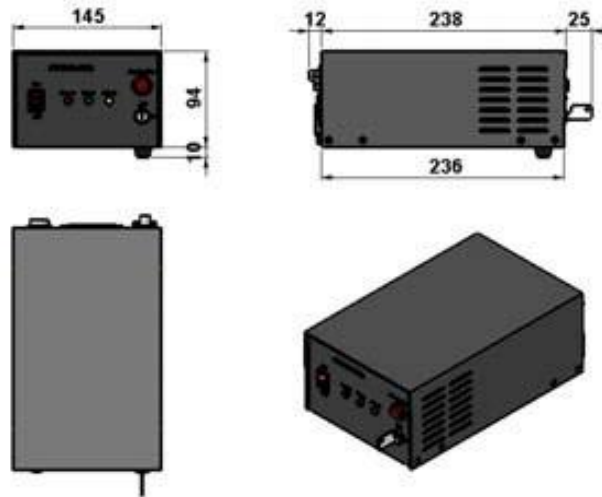

Note: The above specifications are subject to change without notice.