

QSL1319 Series 1319nm Passively Q-Switched Laser System up to 5uJ

Overview

The QSL1319 series diode pumped solid state (DPSS) Q-switched laser is ideal for applications that require a wavelength of 1319nm and single pulse energy levels up to 5uJ. The laser features high peak power, high repetition rate, and short pulse duration. The laser is widely used in industry (marking on diamond or stone), teaching of nonlinear optics, fiber communication, and many other applications.



Specifications

Model Number		QSL1319-XYPR
Wavelength (nm)		1319±1
Operating mode		Q-switched pulsed laser
Single pulse energy (µJ)		~5 (X=5)
Average power stability (rms, over 4 hours)		<5% (P=A), <3% (P=E), <2% (P=2), <1% (P=D)
Pulse duration (ns)		~10
Peak power (W)		Peak Power (W) = Single Pulse Energy (µJ) / Pulse Duration (µs)
Repetition rate (kHz)	Fixed	One fixed rep. rate internal between 1kHz-4kHz, such as 1kHz (R=S1), 2kHz (R=S2), 3kHz (R=S3) and 4kHz (R=S4) with stable pulse energy, pulse duration and pulse period.
	External Trigger	Rep. rate in the range of 1kHz-4kHz obtained by external trigger with stable pulse energy, pulse duration and pulse period. (R=C)
	QCW	QCW state with one rep. rate between 10kHz-20kHz. (R=U)
Average power (mW)		Average power (mW) = Single pulse energy (µJ) * Rep. rate (kHz)
Transverse mode		TEM ₀₀
Beam divergence, full angle (mrad)		<1.5
Beam diameter at aperture (mm)		~1.5
Warm-up time (minutes)		<10
Beam height from base plate (mm)		24.8
Operating temperature (°C)		10-35
Dimensions of laser head (mm)		140.5(L)×73(W) ×46.2(H) mm ³
Weight of laser head (kg)		0.6 kg
Power supply		
Elite Power Supply (Y=E)	Input voltage	90-264VAC
	Dimensions	171(L) ×130(W) ×62.2(H) mm ³
	Weight	1.2 kg
	Notes	Fixed output power
Warranty period		10 months
Expected lifetime (hours)		10,000
FDA Compliance		FDA CDRH Title 21 CFR 1040.10/11 Class IV

Remarks:

- Specifications of the Q-switched pulsed laser is based on the laser pulsed at the specified repetition rate. If the laser is run at a different repetition rate, the output characteristics may change.

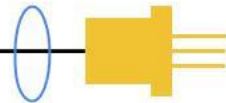

Outline Dimensions (unit: mm)

Laser Head

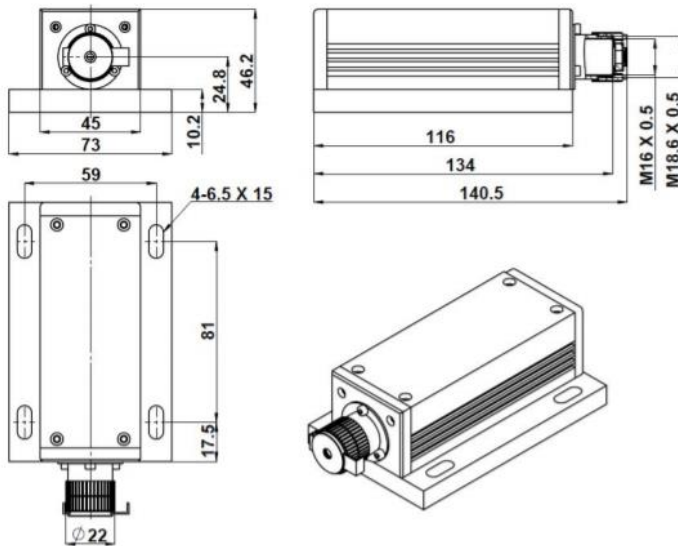

Power Supply

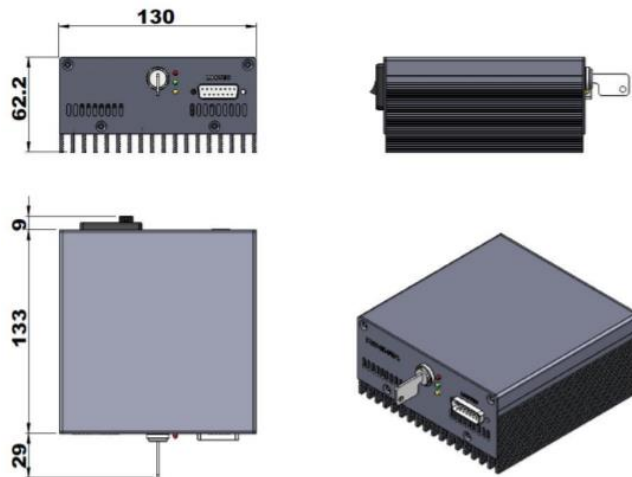

Note: The above specifications are subject to change without notice.