



QEOQ532 Series 532nm High Energy DPSS Q-Switched Laser up to 20mJ

Overview

The QEOQ532 series high energy diode-pumped solid-state (DPSS) Q-switched EOM (Electro-Optic Modulation) laser is ideal for applications that require a wavelength of 532nm and single pulse energy levels up to 20mJ. The laser is constructed with features of high single pulse energy, short pulse duration, and high peak power. The laser is widely used in PIV, LIF, LIBS, ICP-MS, scientific research, laser processing, military, and many other applications.



Specifications

Model Number	QEOQ532-XYP-C				
Wavelength (nm)	532±1				
Operating mode	Q-switched: EOM (Electro-optic modulation)				
Single pulse energy (mJ)	~2 (X=2)	~5 (X=5)	~10 (X=10)	~15 (X=15)	~20 (X=20)
Pulse duration (ns)	<12	<12	<12	<10	<10
Repetition rate (Hz)	1000	1-100 (adjustable)			
Energy stability	<5% (P=A), <3% (P=E)				
Beam divergence, full angle (mrad)	~2				
Beam diameter (mm)	~1.5	~2	~2.5	~3	~4
Warm-up time (minutes)	<15				
Beam height from base plate (mm)	55				
Cooled method	Water Cooled				
Operating temperature (°C)	15-35				
Dimensions of laser head (mm)	437(L) x160(W) x100(H) mm ³				
Weight of laser head (kg)	7.5 kg				
Power supply (Y=DQ)	Input voltage	220/110VAC	220/110VAC		
	Dimensions	612(L) x 480(W) x150(H) mm ³	323(L) x 306(W) x106(H) mm ³		
	Weight	15 kg	4 kg		
	Features	Repetition rate and current can be adjusted by touch screen.			
Dimensions of water chiller (mm)	580(L) x290(W) x470(H) mm ³				
Weight of water chiller (kg)	24 kg				
Expected lifetime (pulses)	10 ⁹				
Warranty period	10 months				
FDA Compliance	FDA CDRH Title 21 CFR1040.10/11 Class IIIb				

Remarks:

- Specifications of the Q-switched pulsed laser is based on the laser pulsed at the specified repetition rate. If the laser is run at a different repetition rate, the output characteristics may change.

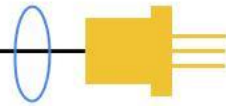

Outline Dimensions (unit: mm)

Laser Head

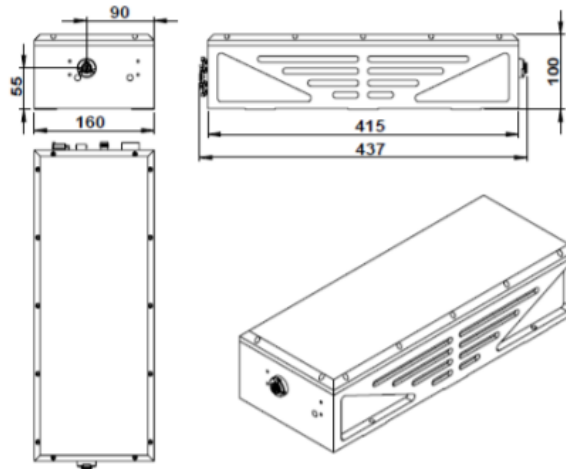

Power Supply

For Repetition rate 1000Hz

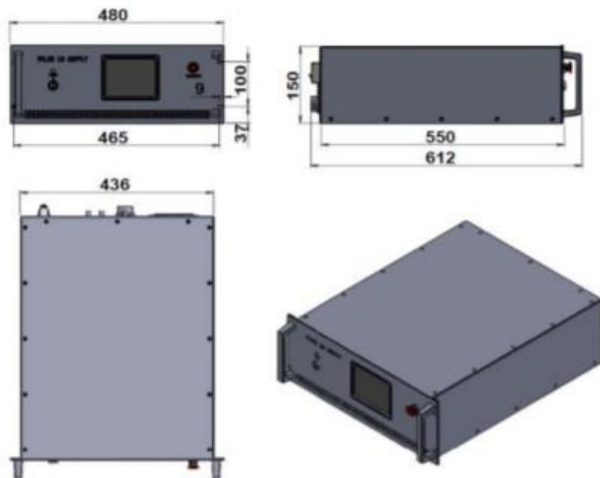

For Repetition rate 100Hz

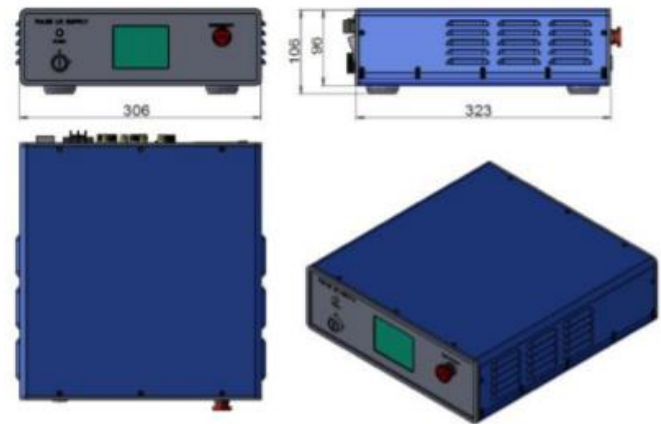

Water Chiller

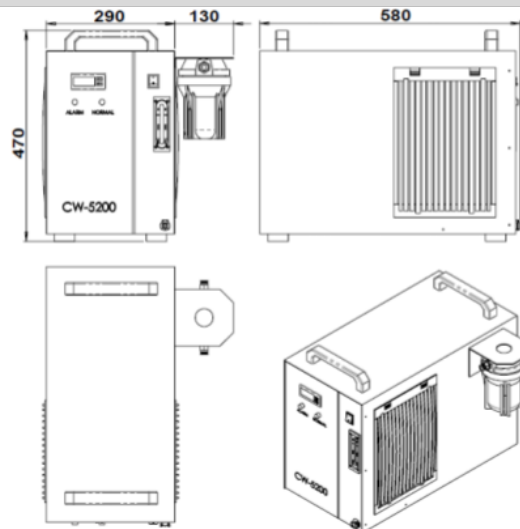

Note: The above specifications are subject to change without notice.