



1.25Gbps 1260nm~1620nm InGaAs PIN plus AGC Pre-Amplifier Photodiode in TO-46 Package, 4-pin

Part No. PDT-A13P4-1GD3

Features

- 1310nm/1550nm InGaAs PINTIA 4 pin TO
- Industry standard TO-46 package with cap lens
- Optimized for fiber optic application
- Design for long wavelength 1.25Gbps applications
- Single power supply +3.3V



Specifications

Electro-Optical Characteristics (Typical values are at + 3.3V@25°C)						
Parameters	Symbol	Min.	Typ.	Max.	Unit	Conditions
Power Supply	V _{CC}	3.0	3.3	3.6	V	
Supply Current	I _{CC}		22	30	mA	No loads
Differential Responsivity	R _d	14		30	mV/uW	λ=1310nm, R _{load} =100ohm, P=-26dBm
Single Ended Responsivity	R _s	7		15	mV/uW	λ=1310nm, R _{load} =50ohm, P=-26dBm
Small-Signal Bandwidth	BW	700			MHz	
Low-Frequency Cut Off	LF			100	kHz	
Rise/Fall Time (20-80%)	tr/tf			400	ps	P=-26dBm, T _A =25°C
Saturation Power	P _{sat}	0			dBm	
Single Ended Output Impedance	R _O		50		ohm	
Wavelength	λ	1260		1620	nm	
Sensitivity				-28	dBm	λ=1310nm, @1244.16Mbps, PRBS7, ER=10dB, BER=10 ⁻¹⁰

Absolute Maximum Ratings					
Parameters	Min.	Max.	Unit	Conditions	
Storage Temperature	-40	100	°C		
Operating Temperature	-40	85	°C		
Lead Solder Temperature		260	°C	10 seconds	

Outline Dimensions (unit: mm)

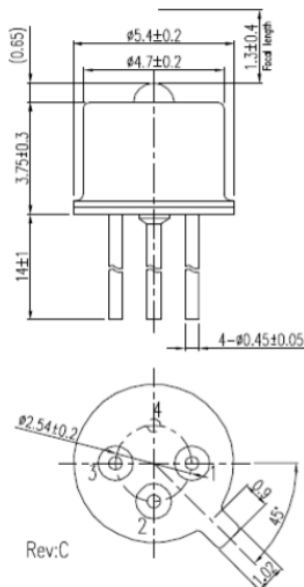

Pinout

1. Dout
2. V_{CC}
3. Dout
4. Gnd

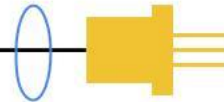

Typical Characteristics

Eye Diagram

$R_{load} = 50\Omega$, $P = -26\text{dBm}$ @1244.16Mbps, 1310nm, PRBS 7

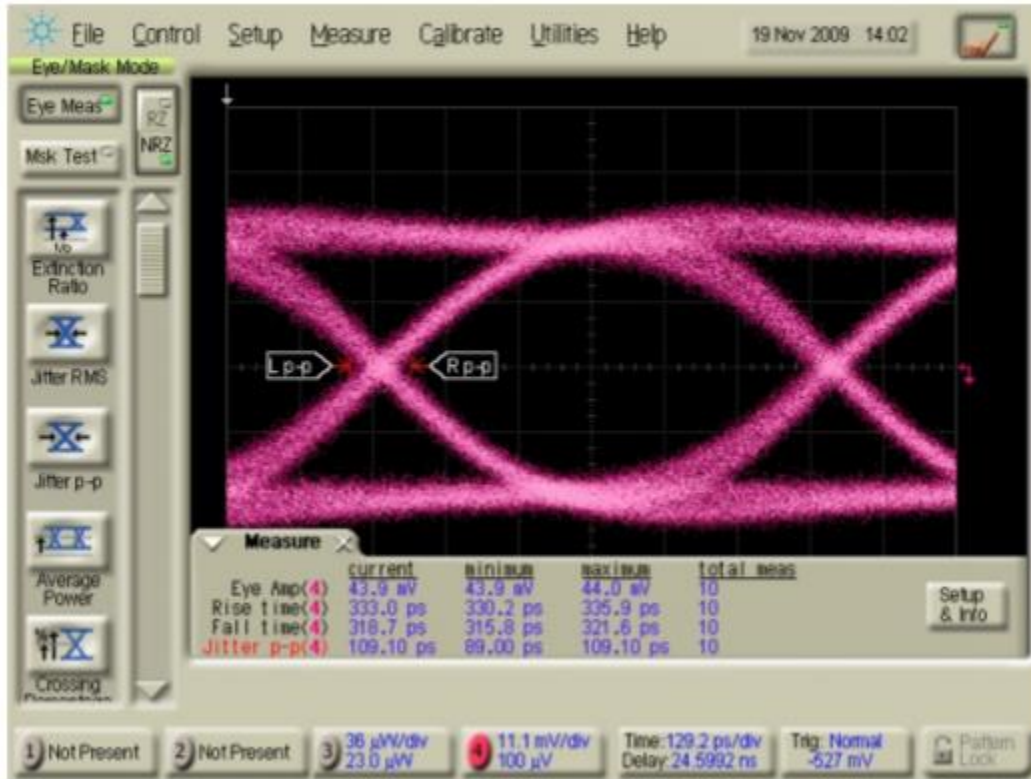

$t_r=333.0\text{ps}$, $t_f=318.7\text{ps}$, Jitter p-p=109.1ps

Note: Specifications are subject to change without notice.