

850nm 5mW 60°C Laser Diode in TO-33 ϕ 3.3mm Package

Part No. LD850A5A16

FEATURES

- 850nm 5mW CW AlGaAs Laser Diode
- Package: TO-33 (dia. 3.3mm)
- Built-in photodiode for monitoring laser diode
- Attractive light source

APPLICATIONS

- Motion recognition sensor
- Industrial optical module

ABSOLUTE MAXIMUM RATINGS

Parameter	Symbol	Condition	Rating	Unit
Optical output power	P_O	CW	7	mW
Reverse voltage (LD)	V_{RL}	-	2	V
Reverse voltage (PD)	V_{RD}	-	30	V
Operating temperature	T_{opr}	-	-10 to +60	°C
Storage temperature	T_{stg}	-	-40 to +85	°C

ELECTRICAL AND OPTICAL CHARACTERISTICS ($T_C = 25^\circ\text{C}$)

Parameter	Symbol	Min.	Typ.	Max.	Unit	Conditions
Lasing wavelength	λ_p	845	852	855	nm	$P_O = 5\text{mW}$
Threshold current	I_{th}	5	11	20	mA	
Operating current	I_{op}	12	17	30	mA	$P_O = 5\text{mW}$
Differential Efficiency	η	0.4	0.7	0.9	mW/mA	$P_O = 2\text{-}5\text{mW}$
Operating voltage	V_{op}	-	1.8	2.5	V	$P_O = 5\text{mW}$
Monitor current	I_m	0.05	0.15	0.4	mA	$P_O = 5\text{mW}$
Parallel divergence angle	$\Theta_{//}$	7	9	12	deg	$P_O = 5\text{mW}$
Perpendicular divergence angle	Θ_{\perp}	25	32	40	deg	$P_O = 5\text{mW}$
Parallel FFP deviation angle	$\Delta \Theta_{//}$	-3	0	+3	deg	$P_O = 5\text{mW}$
Perpendicular FFP deviation angle	$\Delta \Theta_{\perp}$	-3	0	+3	deg	$P_O = 5\text{mW}$
Astigmatism	A_s			15	um	
Emission point accuracy	$\Delta x \Delta y \Delta z$	-60	0	+60	um	

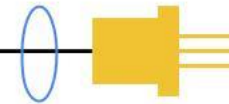

MECHANICAL OUTLINE (unit: mm)

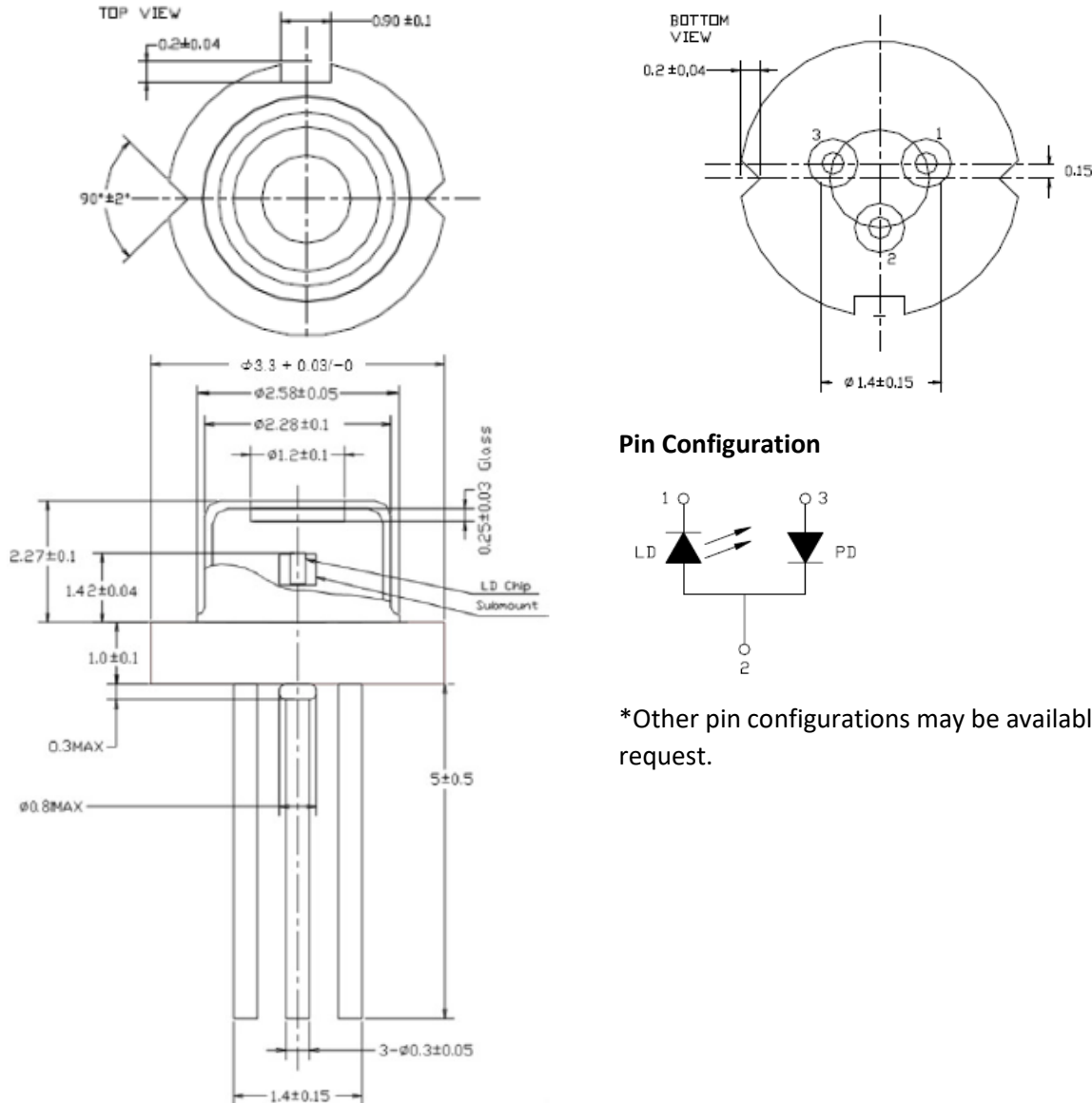

Pin Configuration

*Other pin configurations may be available upon request.

ADDITIONAL NOTES

- Do not operate the device above maximum ratings. Doing so may cause unexpected and permanent damage to the device.
- Take precautions to avoid electrostatic discharge and/or momentary power spikes. A change in the characteristics of the laser or premature failure may result.
- Proper heat sinking of the device assures stability and lifetime. Always ensure that maximum operating temperatures are not exceeded.
- Observing visible or invisible laser beams with human eye directly, or indirectly, can cause permanent damage. Use a camera to observe the laser.
- No laser device should be used in any application or situation where life or property is at risk in the event of device failure.
- Specifications are subject to change without notice. Ensure that you have the latest specification by contacting us prior to purchase or use of the product.