

## 808nm 8000mW 30°C Laser Diode in C-Mount Package

Part No. LD808E8WG13

### FEATURES

- 808nm 8W Fabry-Perot cavity semiconductor laser
- High power
- Package: C-Mount

### SPECIFICATIONS (T<sub>c</sub> = 20°C)

Item	Parameter	Typ.	Unit
Optical Parameter	Lasing wavelength	808±5	nm
	Output power	8	W
	Spectral width	≤5	nm
	Emitting area width	200	um
	Temperature coefficient	0.30	nm/°C
	Fast axis divergence	<40	deg
	Slow axis divergence	<10	deg
Electrical Parameter	Slope efficiency	≥1.0	W/A
	Threshold current	≤1.8	A
	Operating current	≤10.0	A
	Operating voltage	≤2.0	V
Others	Package	C-Mount	-
	Operating temperature	15 to 30	°C
	Storage temperature	-40 to +60	°C
	Welding temperature	≤260	°C

### TYPICAL CHARACTERISTICS

P-I-V Curve

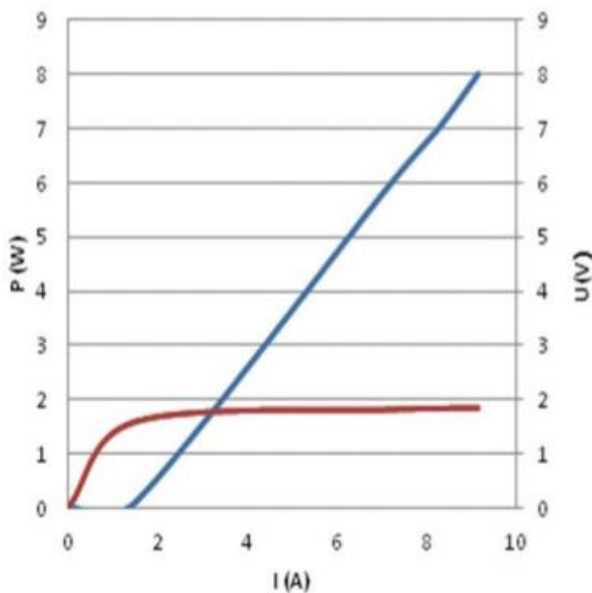

Spectral Curve

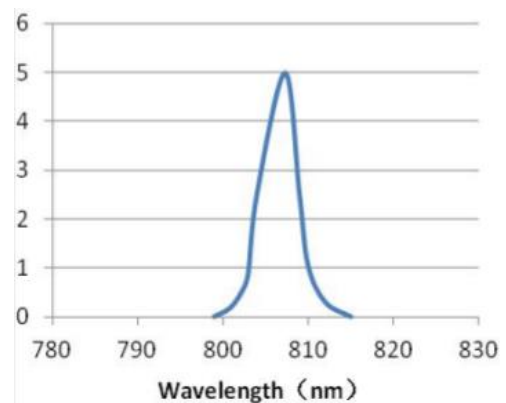

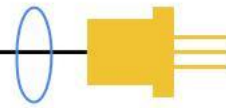

**MECHANICAL OUTLINE (unit: mm)**

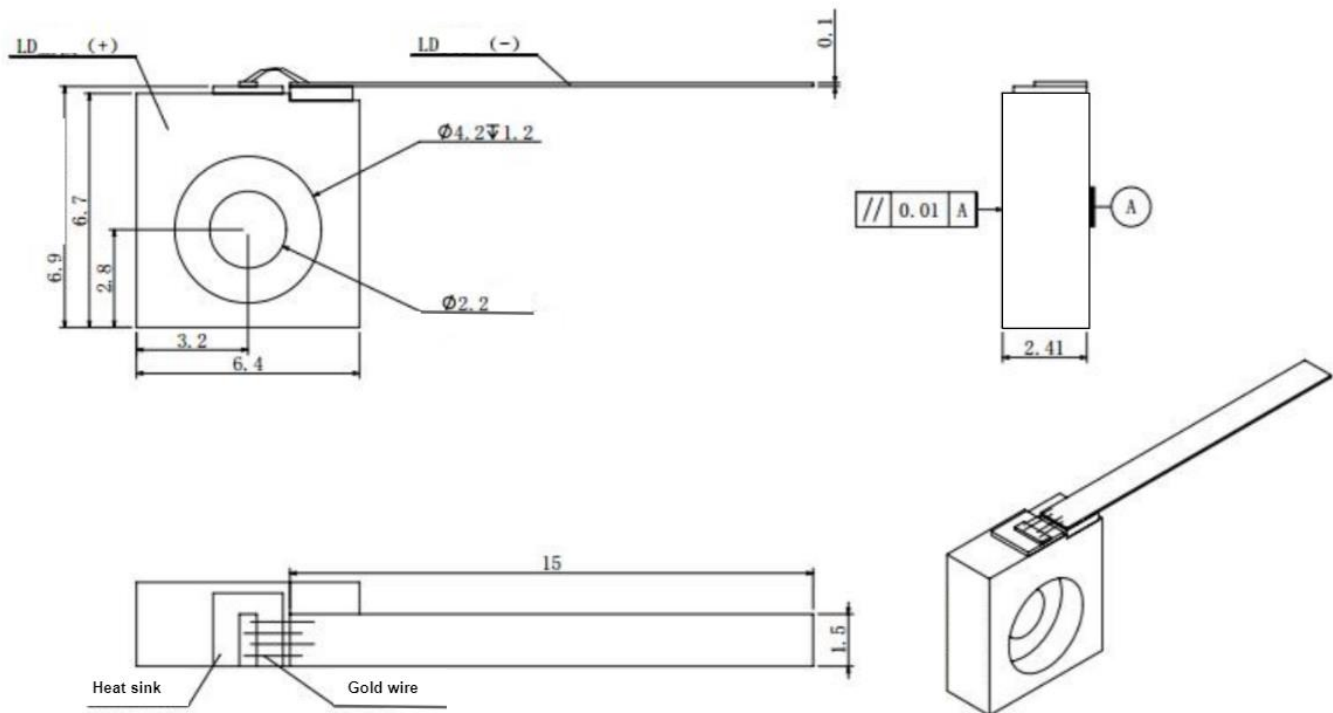

**ADDITIONAL NOTES**

- Data in the sheet are based on CoS package testing.
- Do not operate the device above maximum ratings. Doing so may cause unexpected and permanent damage to the device.
- Take precautions to avoid electrostatic discharge and/or momentary power spikes. A change in the characteristics of the laser or premature failure may result.
- Proper heat sinking of the device assures stability and lifetime. Always ensure that maximum operating temperatures are not exceeded.
- Observing visible or invisible laser beams with human eye directly, or indirectly, can cause permanent damage. Use a camera to observe the laser.
- No laser device should be used in any application or situation where life or property is at risk in the event of device failure.
- Specifications are subject to change without notice. Ensure that you have the latest specification by contacting us prior to purchase or use of the product.