

## 780nm 50mW 60°C Laser Diode in TO-18 $\phi$ 5.6mm Package

Part No. LD780A50C16

### FEATURES

- 780nm 50mW CW AlGaAs Laser Diode
- Package: TO-18 (dia. 5.6mm)
- Built-in photodiode for monitoring laser diode

### APPLICATIONS

- Industrial optical module
- Sensor

### ABSOLUTE MAXIMUM RATINGS

Parameter	Symbol	Condition	Rating	Unit
Optical output power	$P_O$	CW	50	mW
Reverse voltage (LD)	$V_{RL}$	-	2	V
Reverse voltage (PD)	$V_{RD}$	-	30	V
Operating temperature	$T_{opr}$	-	-10 to +60	°C
Storage temperature	$T_{stg}$	-	-40 to +85	°C

### ELECTRICAL AND OPTICAL CHARACTERISTICS ( $T_C = 25^\circ\text{C}$ )

Parameter	Symbol	Min.	Typ.	Max.	Unit	Conditions
Lasing wavelength	$\lambda_p$	775	785	795	nm	$P_O = 50\text{mW}$
Threshold current	$I_{th}$	-	25	40	mA	-
Operating current	$I_{op}$	-	75	100	mA	$P_O = 50\text{mW}$
Differential Efficiency	$\eta$	0.6	1.0	1.4	mW/mA	$40\text{mW}/I(45\text{mW}) - I(5\text{mW})$
Operating voltage	$V_{op}$	-	2	2.8	V	$P_O = 50\text{mW}$
Monitor current	$I_m$	0.1	0.25	0.6	mA	$P_O = 50\text{mW}$
Parallel divergence angle	$\Theta_{//}$	7	9	12	deg	$P_O = 50\text{mW}$
Perpendicular divergence angle	$\Theta_{\perp}$	17	22	27	deg	$P_O = 50\text{mW}$
Parallel FFP deviation angle	$\Delta \Theta_{//}$	-2	0	+2	deg	
Perpendicular FFP deviation angle	$\Delta \Theta_{\perp}$	-3	0	+3	deg	
Astigmatism	$A_s$	-	5	-	um	$P_O = 50\text{mW}$
Emission point accuracy	$\Delta x \Delta y \Delta z$	-60	0	+60	um	

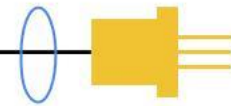

## MECHANICAL OUTLINE (unit: mm)

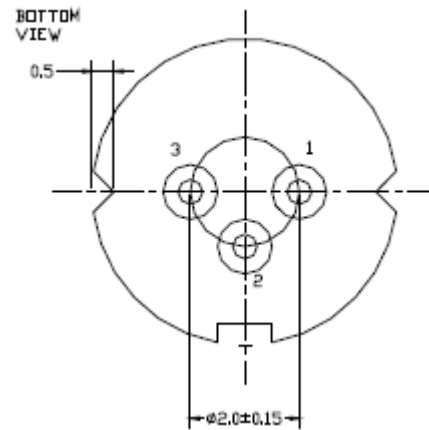
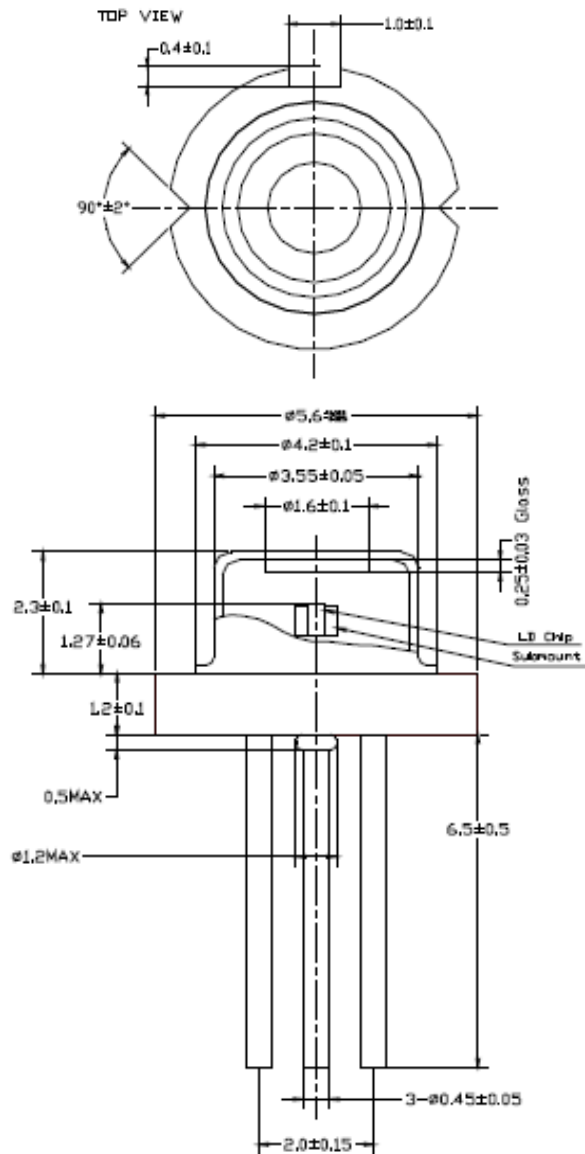

### Pin Configuration

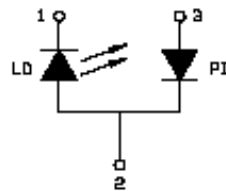

\*Other pin configurations may be available upon request.

### ADDITIONAL NOTES

- Do not operate the device above maximum ratings. Doing so may cause unexpected and permanent damage to the device.
- Take precautions to avoid electrostatic discharge and/or momentary power spikes. A change in the characteristics of the laser or premature failure may result.
- Proper heat sinking of the device assures stability and lifetime. Always ensure that maximum operating temperatures are not exceeded.
- Observing visible or invisible laser beams with human eye directly, or indirectly, can cause permanent damage. Use a camera to observe the laser.
- No laser device should be used in any application or situation where life or property is at risk in the event of device failure.
- Specifications are subject to change without notice. Ensure that you have the latest specification by contacting us prior to purchase or use of the product.