

780nm 10mW 70°C Laser Diode in TO-18 ϕ 5.6mm Package

Part No. LD780A10C17

FEATURES

- 780nm 10mW CW Laser Diode
- Package: TO-18 (dia. 5.6mm)
- Low operating current
- High efficiency
- High operating temperature

APPLICATIONS

- Laser printer light source
- Industrial tool

ABSOLUTE MAXIMUM RATINGS

Parameter	Symbol	Condition	Rating	Unit
Optical output power	P_O	CW	12	mW
Reverse voltage (LD)	V_{RL}	-	2	V
Reverse voltage (PD)	V_{RD}	-	30	V
Forward current (PD)	I_{FD}	-	10	mA
Operating temperature	T_{opr}	-	-10 to +70	°C
Storage temperature	T_{stg}	-	-40 to +85	°C

ELECTRICAL AND OPTICAL CHARACTERISTICS ($T_C = 25^\circ\text{C}$)

Parameter	Symbol	Min.	Typ.	Max.	Unit	Conditions
Lasing wavelength	λ_p	770	780	790	nm	$P_O = 10\text{mW}$
Threshold current	I_{th}	-	15	25	mA	
Operating current	I_{op}	-	30	40	mA	$P_O = 10\text{mW}$
Differential Efficiency	η	0.4	0.6	0.8	mW/mA	$P_O = 7\text{-}10\text{mW}$
Operating voltage	V_{op}	-	1.9	2.2	V	$P_O = 10\text{mW}$
Monitor current	I_m	0.2	0.6	1.2	mA	$P_O = 10\text{mW}$, $V_{RD} = 5\text{V}$
Parallel divergence angle	$\Theta_{//}$	7	11	15	deg	$P_O = 10\text{mW}$
Perpendicular divergence angle	Θ_{\perp}	24	28	32	deg	$P_O = 10\text{mW}$
Parallel FFP deviation angle	$\Delta \Theta_{//}$	-2	0	+2	deg	$P_O = 10\text{mW}$
Perpendicular FFP deviation angle	$\Delta \Theta_{\perp}$	-3	0	+3	deg	$P_O = 10\text{mW}$
Emission point accuracy	$\Delta x \Delta y \Delta z$	-80	0	+80	um	$P_O = 10\text{mW}$

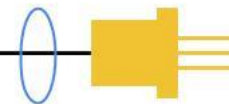

TYPICAL CHARACTERISTICS

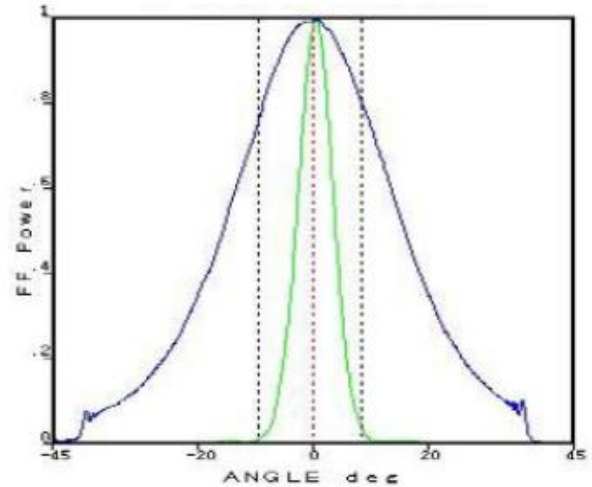
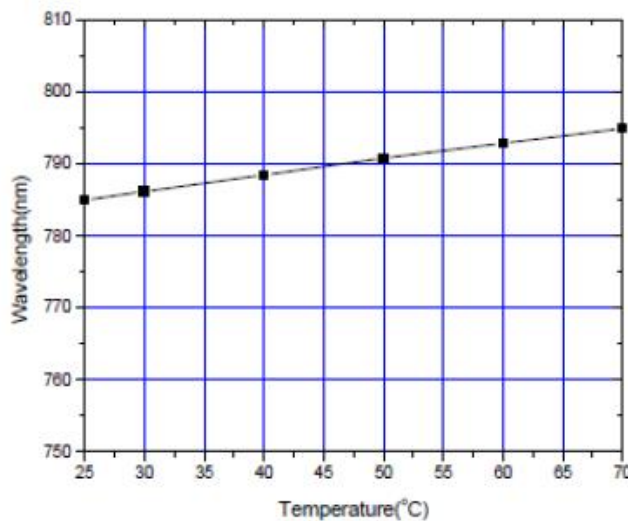
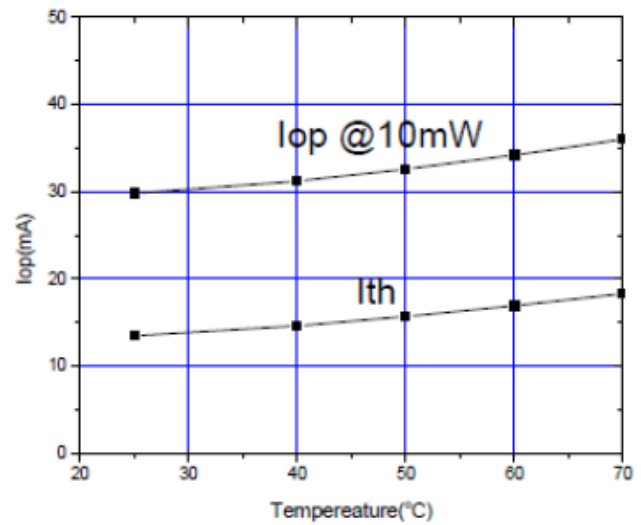
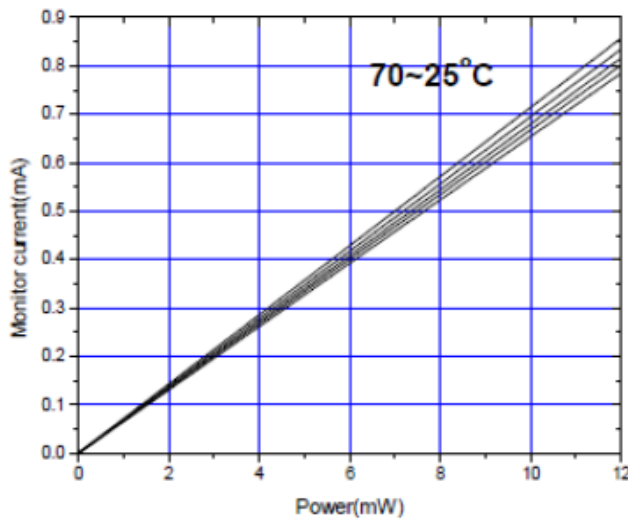
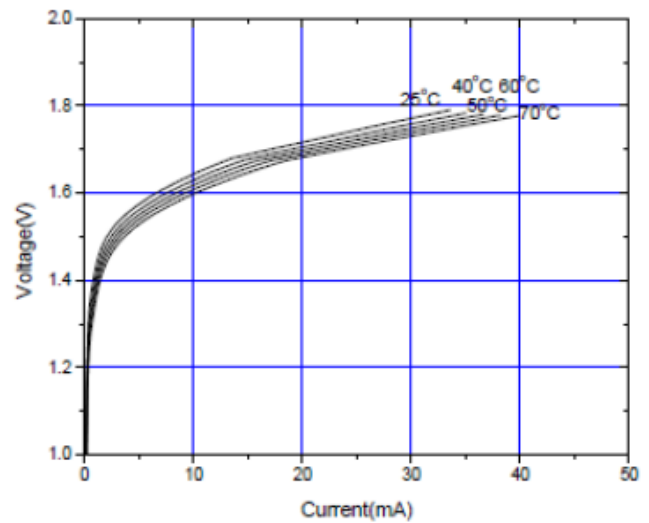
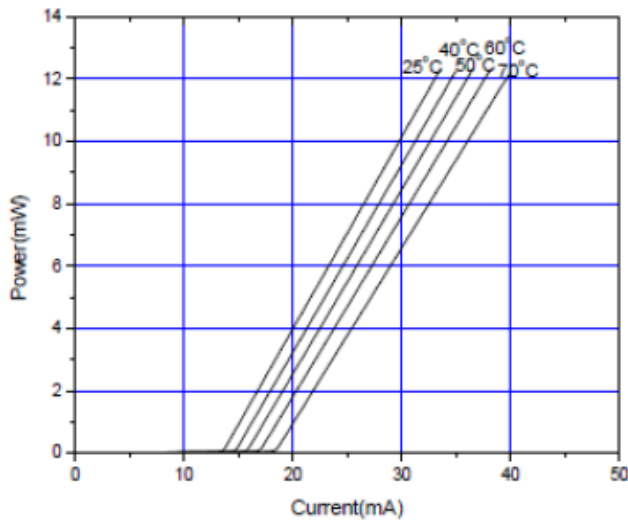

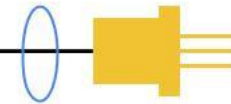

MECHANICAL OUTLINE (unit: mm)

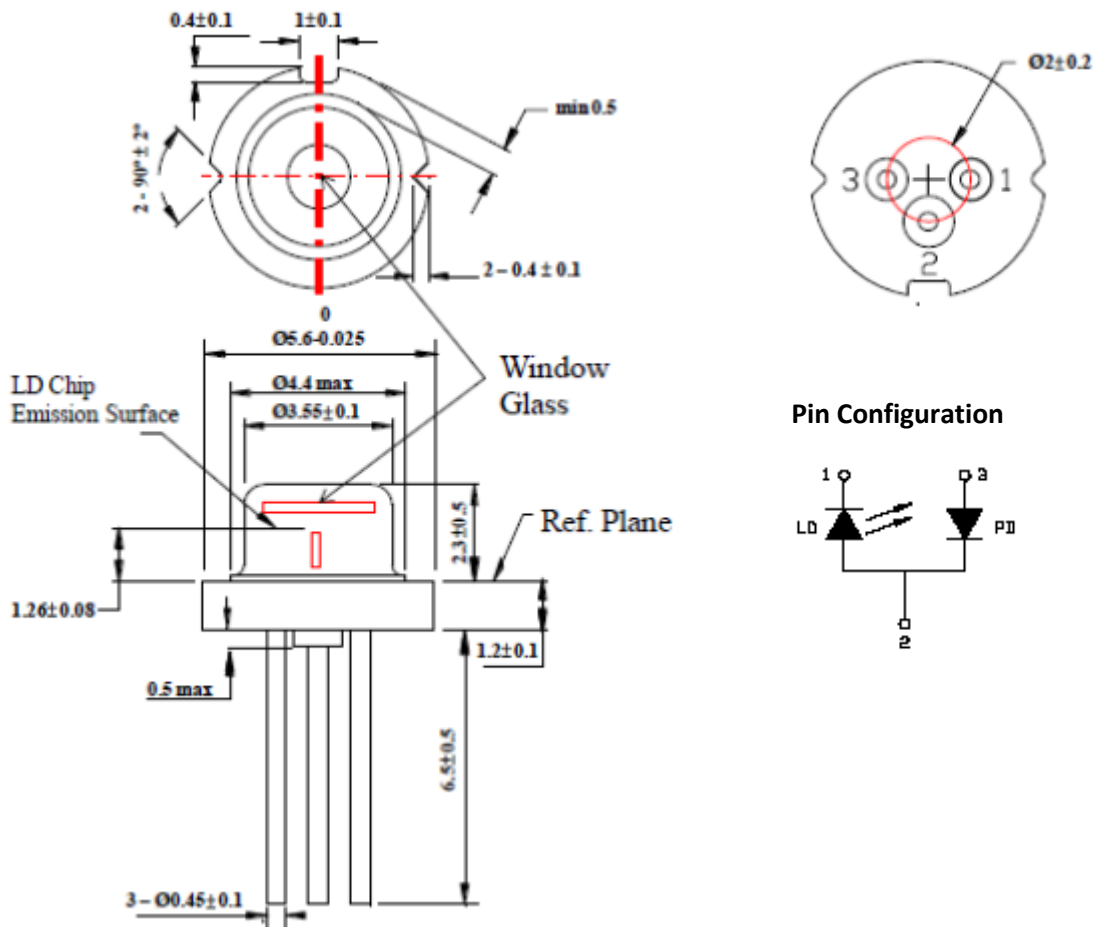

ADDITIONAL NOTES

- Do not operate the device above maximum ratings. Doing so may cause unexpected and permanent damage to the device.
- Take precautions to avoid electrostatic discharge and/or momentary power spikes. A change in the characteristics of the laser or premature failure may result.
- Proper heat sinking of the device assures stability and lifetime. Always ensure that maximum operating temperatures are not exceeded.
- Observing visible or invisible laser beams with human eye directly, or indirectly, can cause permanent damage. Use a camera to observe the laser.
- No laser device should be used in any application or situation where life or property is at risk in the event of device failure.
- Specifications are subject to change without notice. Ensure that you have the latest specification by contacting us prior to purchase or use of the product.