**670nm 10mW 70°C Laser Diode in TO-18  $\phi$ 5.6mm Package**

Part No. LD670A10C17

**FEATURES**

- 670nm 10mW CW Index-guided InGaAlP Diode
- Package: TO-18 (dia. 5.6mm)
- Built-in photodiode for monitoring laser diode

**APPLICATIONS**

- Laser module
- Optical leveler
- Bar code reader

**ABSOLUTE MAXIMUM RATINGS**

Parameter	Symbol	Condition	Rating	Unit
Optical output power	$P_O$	CW	12	mW
Reverse voltage (LD)	$V_{RL}$	-	2	V
Reverse Voltage (PD)	$V_{RD}$	-	30	V
Operating temperature	$T_{opr}$	-	-10 to +70	°C
Storage temperature	$T_{stg}$	-	-40 to +85	°C

**ELECTRICAL AND OPTICAL CHARACTERISTICS ( $T_C = 25^\circ\text{C}$ )**

Parameter	Symbol	Min.	Typ.	Max.	Unit	Conditions
Lasing wavelength	$\lambda_p$	660	670	680	nm	$P_O = 10\text{mW}$
Threshold current	$I_{th}$	-	20	40	mA	-
Operating current	$I_{op}$	-	40	80	mA	$P_O = 10\text{mW}$
Monitor Current	$I_m$	0.1	0.2	0.5	mA	$P_O = 10\text{mW}$
Operating voltage	$V_{op}$	-	2.3	2.6	V	$P_O = 10\text{mW}$
Parallel divergence angle	$\Theta_{//}$	7	9	11	deg	$P_O = 10\text{mW}$
Perpendicular divergence angle	$\Theta_{\perp}$	20	28	35	deg	$P_O = 10\text{mW}$
Parallel FFP deviation angle	$\Delta \Theta_{//}$	-1.5	0	+1.5	deg	$P_O = 10\text{mW}$
Perpendicular FFP deviation angle	$\Delta \Theta_{\perp}$	-2.5	0	+2.5	deg	$P_O = 10\text{mW}$
Astigmatism	As		8		um	
Emission point accuracy	$\Delta x \Delta y \Delta z$	-60	0	+60	um	

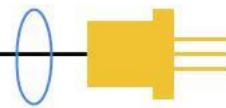

**MECHANICAL OUTLINE (unit: mm)**

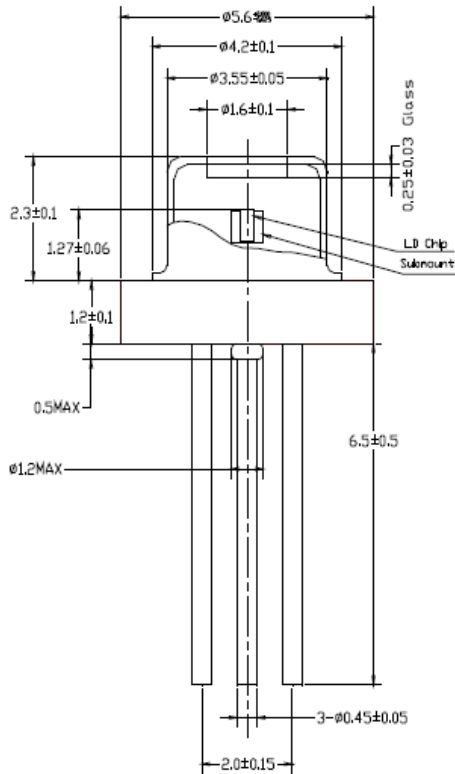
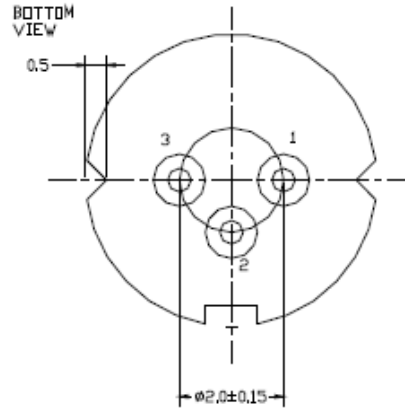
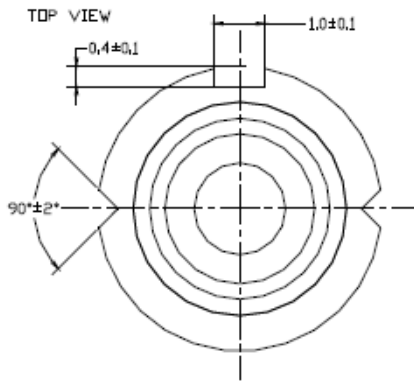

**Pin Configuration**

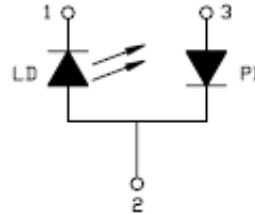

\*Other pin configurations may be available upon request.

**ADDITIONAL NOTES**

- Do not operate the device above maximum ratings. Doing so may cause unexpected and permanent damage to the device.
- Take precautions to avoid electrostatic discharge and/or momentary power spikes. A change in the characteristics of the laser or premature failure may result.
- Proper heat sinking of the device assures stability and lifetime. Always ensure that maximum operating temperatures are not exceeded.
- Observing visible or invisible laser beams with human eye directly, or indirectly, can cause permanent damage. Use a camera to observe the laser.
- No laser device should be used in any application or situation where life or property is at risk in the event of device failure.
- Specifications are subject to change without notice. Ensure that you have the latest specification by contacting us prior to purchase or use of the product.