**660nm 80mW 60°C Laser Diode in TO-18  $\phi$ 5.6mm Package**

Part No. LD660A80C16

**FEATURES**

- 660nm 80mW AlGaInP Visible Laser Diode
- Highly reliable
- Higher power
- Built-in monitor PD
- Package: TO-18 (dia. 5.6mm)

**APPLICATIONS**

- High power laser modules
- Medical applications
- Industrial laser markers / measuring instruments

**ABSOLUTE MAXIMUM RATINGS**

Parameter	Symbol	Condition	Rating	Unit
Light output power	$P_O$	CW	82	mW
Reverse voltage (LD)	$V_{RL}$	-	2	V
Reverse voltage (PD)	$V_{RD}$	-	30	V
Forward current (PD)	$I_{FD}$	-	10	mA
Case temperature	$T_C$	-	-10 to +60	°C
Storage temperature	$T_S$	-	-40 to +85	°C

**ELECTRICAL AND OPTICAL CHARACTERISTICS ( $T_C = 25+/-2$  °C)**

Parameter	Symbol	Min.	Typ.	Max.	Unit	Conditions
Peak wavelength	$\lambda$	654	660	666	nm	$P_O = 80\text{mW}$
Threshold current	$I_{th}$	-	55	80	mA	
Operating current	$I_{op}$	130	150	180	mA	
Operating voltage	$V_{op}$	-	2.6	3.0	V	
Differential efficiency	$\eta$	-	0.85	-	mW/mA	
Monitor current	$I_m$	-	0.5	-	mA	$P_O = 80\text{mW}, V_{RD} = 5\text{V}$
Parallel divergence angle	$\Theta_{//}$	7	10	14	deg	$P_O = 80\text{mW}$
Perpendicular divergence angle	$\Theta_{\perp}$	14	17	22	deg	
Parallel FFP deviation angle	$\Delta \Theta_{//}$	-3	-	+3	deg	
Perpendicular FFP deviation angle	$\Delta \Theta_{\perp}$	-3	-	+3	deg	
Emission point accuracy	$\Delta x \Delta y \Delta z$	-80	-	+80	um	

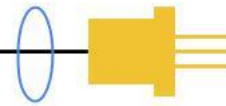

### TYPICAL CHARACTERISTICS

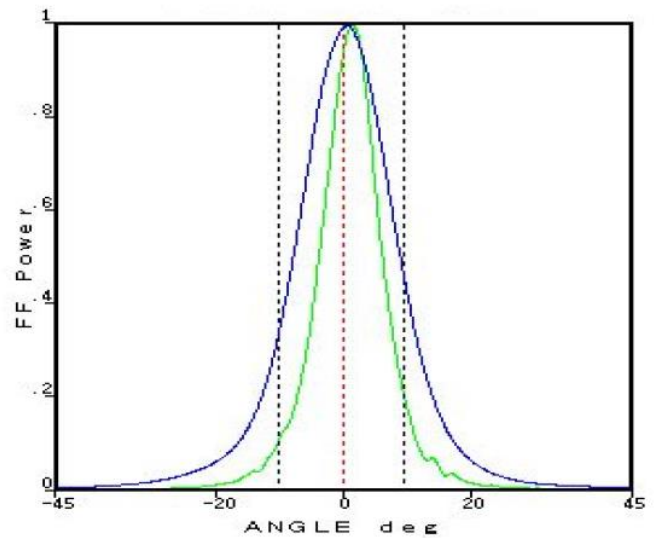
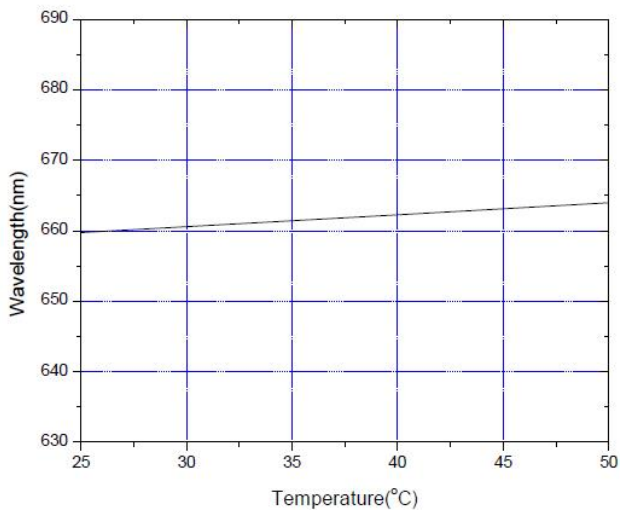
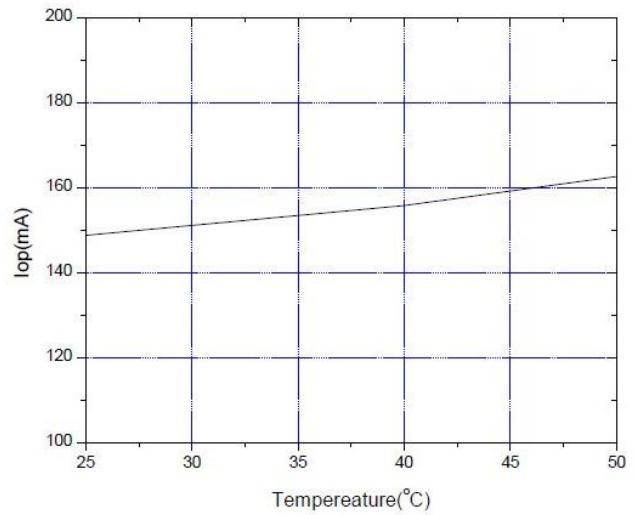
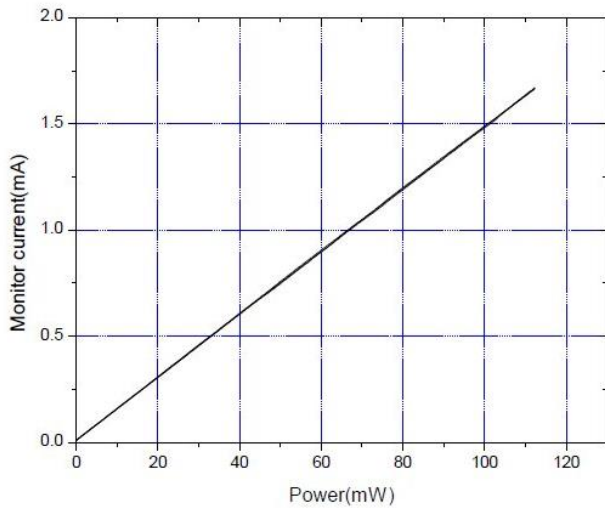
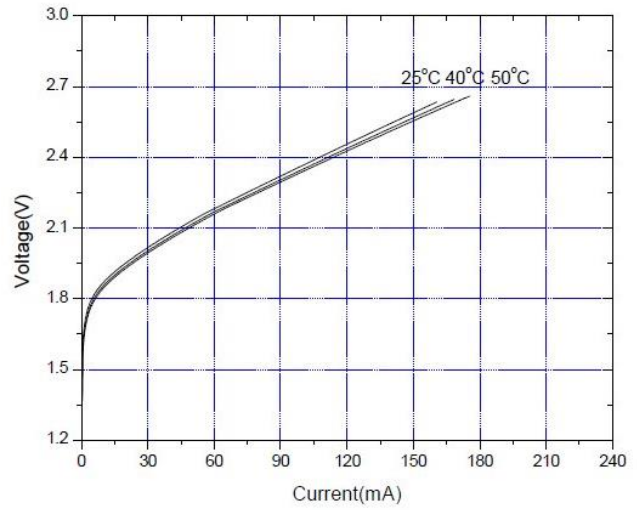
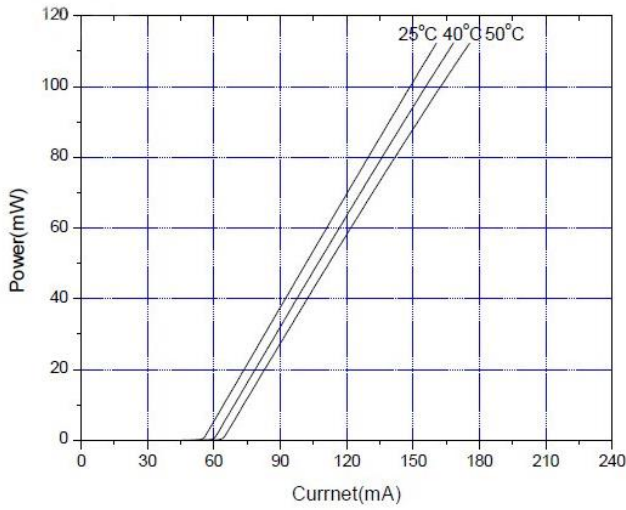

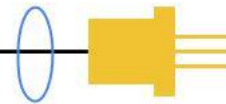

**MECHANICAL OUTLINE (unit: mm)**

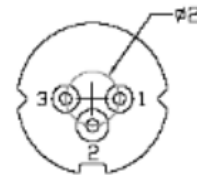
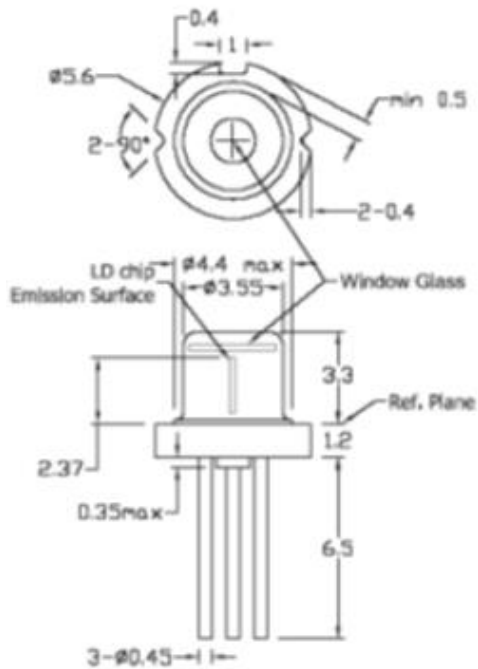

**Pin Configuration**

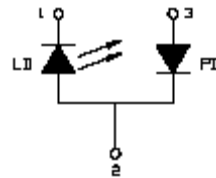

**ADDITIONAL NOTES**

- Do not operate the device above maximum ratings. Doing so may cause unexpected and permanent damage to the device.
- Take precautions to avoid electrostatic discharge and/or momentary power spikes. A change in the characteristics of the laser or premature failure may result.
- Proper heat sinking of the device assures stability and lifetime. Always ensure that maximum operating temperatures are not exceeded.
- Observing visible or invisible laser beams with human eye directly, or indirectly, can cause permanent damage. Use a camera to observe the laser.
- No laser device should be used in any application or situation where life or property is at risk in the event of device failure.
- Specifications are subject to change without notice. Ensure that you have the latest specification by contacting us prior to purchase or use of the product.