

650nm 300mW FP Laser Diode in C-Mount Package

Part No. LD650E300G13

FEATURES

- 650nm 300mW Fabry-Perot cavity semiconductor laser
- High output power
- Package: C-Mount

APPLICATIONS

- Bar code scanner

SPECIFICATIONS (T_c = 20°C)

Item	Parameter	Min.	Typ.	Max.	Unit
Optical Parameter	Lasing wavelength	640	650	660	nm
	Output power	-	300	-	mW
	Spectral width	-	1.0	2.0	nm
	Emitting area width	-	100	-	um
	Temperature coefficient	-	0.30	-	nm/°C
	Fast axis divergence	-	34	38	deg
	Slow axis divergence	-	7	10	deg
Electrical Parameter	Slope efficiency	0.90	-	-	W/A
	Threshold current	-	0.45	0.65	A
	Operating current	-	0.70	1.00	A
	Operating voltage	-	2.00	2.30	V
Others	Package	C-Mount			-
	Operating temperature	10 to 30			°C
	Storage temperature	-10 to +60			°C

MECHANICAL OUTLINE (unit: mm)

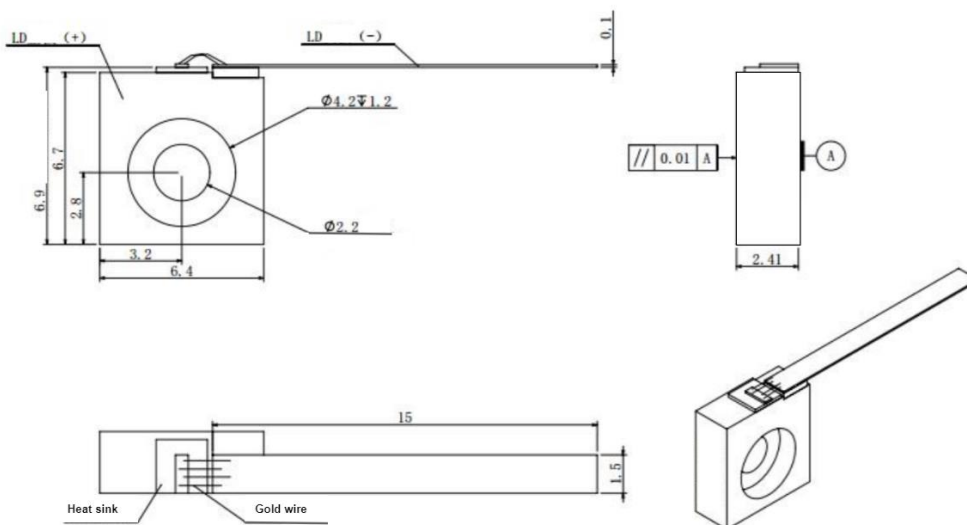

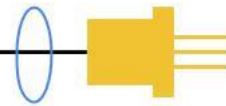

TYPICAL CHARACTERISTICS

P-I-V Curve

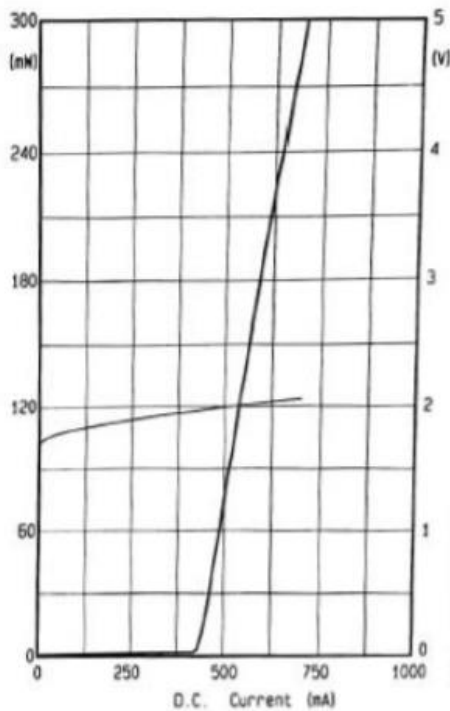

Spectral Curve

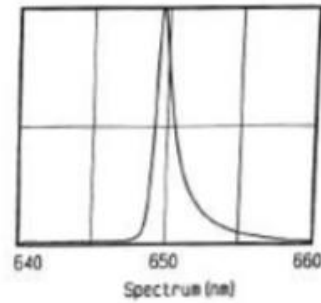

ADDITIONAL NOTES

- Do not operate the device above maximum ratings. Doing so may cause unexpected and permanent damage to the device.
- Take precautions to avoid electrostatic discharge and/or momentary power spikes. A change in the characteristics of the laser or premature failure may result.
- Proper heat sinking of the device assures stability and lifetime. Always ensure that maximum operating temperatures are not exceeded.
- Observing visible or invisible laser beams with human eye directly, or indirectly, can cause permanent damage. Use a camera to observe the laser.
- No laser device should be used in any application or situation where life or property is at risk in the event of device failure.
- Specifications are subject to change without notice. Ensure that you have the latest specification by contacting us prior to purchase or use of the product.