**650nm 35mW 70°C Laser Diode in TO-18 ϕ 5.6mm Package**

Part No. LD650A35C17

FEATURES

- 650nm 35mW CW InGaAlP Diode
- Package: TO-18 (dia. 5.6mm)
- Built-in photodiode for monitoring laser diode

APPLICATIONS

- DVD-Ram
- Industrial sensor

ABSOLUTE MAXIMUM RATINGS

Parameter	Symbol	Condition	Rating	Unit
Optical output power	P_O	CW	40	mW
Reverse voltage (LD)	V_{RL}	-	2	V
Reverse Voltage (PD)	V_{RD}	-	30	V
Operating temperature	T_{opr}	-	-10 to +70	°C
Storage temperature	T_{stg}	-	-40 to +85	°C

ELECTRICAL AND OPTICAL CHARACTERISTICS ($T_C = 25^\circ\text{C}$)

Parameter	Symbol	Min.	Typ.	Max.	Unit	Conditions
Lasing wavelength	λ_p	645	658	665	nm	$P_O = 35\text{mW}$
Threshold current	I_{th}	20	35	50	mA	-
Operating current	I_{op}	40	75	110	mA	$P_O = 35\text{mW}$
Monitor Current	I_m	0.05	0.30	1.50	mA	$P_O = 35\text{mW}$
Differential Efficiency	η	0.6	0.85	1.1	mW/mA	20-35mW
Operating voltage	V_{op}	1.8	2.2	2.6	V	$P_O = 35\text{mW}$
Parallel divergence angle	$\theta_{//}$	7	10	14	deg	$P_O = 35\text{mW}$
Perpendicular divergence angle	θ_{\perp}	16	20	27	deg	$P_O = 35\text{mW}$
Parallel FFP deviation angle	$\Delta \theta_{//}$	-3	0	+3	deg	$P_O = 35\text{mW}$
Perpendicular FFP deviation angle	$\Delta \theta_{\perp}$	-3	0	+3	deg	$P_O = 35\text{mW}$
Emission point accuracy	$\Delta x \Delta y \Delta z$	-60	0	+60	um	

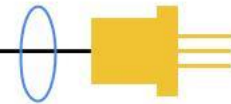

MECHANICAL OUTLINE (unit: mm)

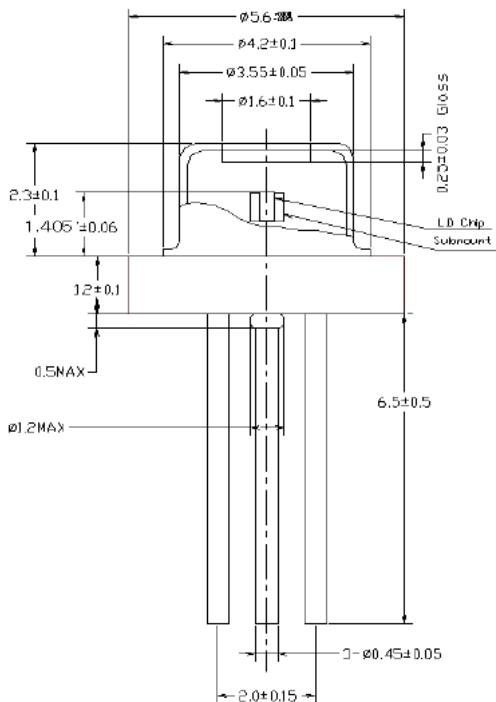
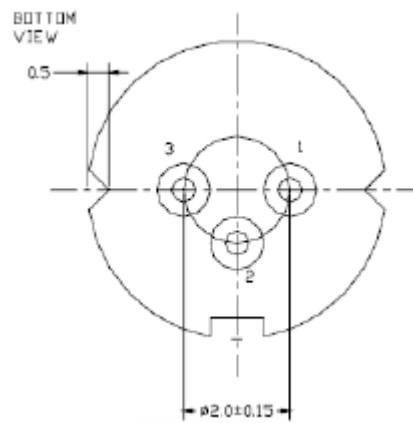
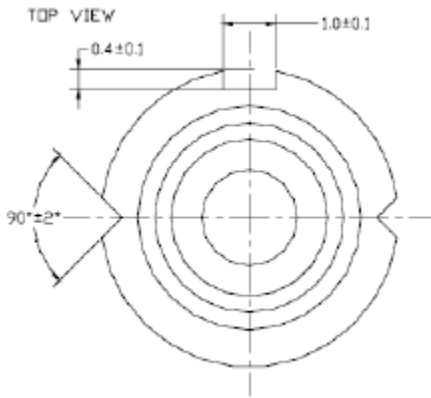

Pin Configuration

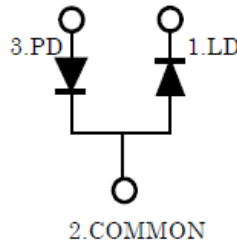

*Other pin configurations may be available upon request.

ADDITIONAL NOTES

- Do not operate the device above maximum ratings. Doing so may cause unexpected and permanent damage to the device.
- Take precautions to avoid electrostatic discharge and/or momentary power spikes. A change in the characteristics of the laser or premature failure may result.
- Proper heat sinking of the device assures stability and lifetime. Always ensure that maximum operating temperatures are not exceeded.
- Observing visible or invisible laser beams with human eye directly, or indirectly, can cause permanent damage. Use a camera to observe the laser.
- No laser device should be used in any application or situation where life or property is at risk in the event of device failure.
- Specifications are subject to change without notice. Ensure that you have the latest specification by contacting us prior to purchase or use of the product.