



915nm 200W Fiber Coupled Laser Diode for Fiber Laser Pumping Application

Part No. HBFC915P200W

Overview

The HBFC915P200W laser diode is a 915nm multimode fiber-coupled laser diode that offers high brightness with up to 200W of optical power output with a 200um core optical fiber. Compact yet reliable, it is in an air-cooled package with isolated electrical pins to ensure user-friendliness. The laser diode is the most cost-effective solution for pumped Yb-doped fiber lasers.

Features

- Single emitter-based laser diode module
- 915nm wavelength
- 200W output power
- 0.22NA, 200um fiber core diameter
- 52% E-O conversion efficiency

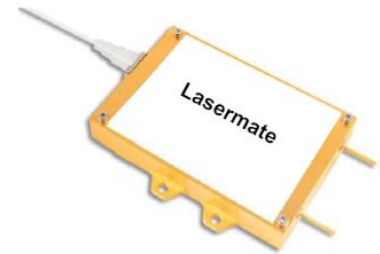

Applications

- Direct processing
- Fiber laser pumping
- Medical
- Analysis

Specifications

Absolute Maximum Ratings				
Parameter	Symbol	Min.	Max.	Unit
Output power	P_O	200		W
Forward current	I_{OP}		18	A
Reverse voltage	V_{RVS}		2	V
Case operating temperature	T_{op}	15	40	°C
Storage temperature	T_{stg}	-20	70	°C

Electrical-Optical Characteristics ($T_{op} = 25^{\circ}C$)					
Parameter	Symbol	Min.	Typ.	Max.	Unit
Output power	P_O	200			W
Center wavelength	λ_c	908	918	928	nm
Spectral width (FWHM)	$\Delta\lambda$		6		nm
Spectral temperature shift	$\Delta\lambda/\Delta T$		0.3		nm/°C
Electrical-to-optical efficiency	PE	46	52		%
Threshold current	I_{th}		0.9		A
Operating current	I_{op}		16.5	18	A
Operating voltage	V_{op}		23	24	V
Slope efficiency	η		12.8		W/A

Fiber Specifications					
Parameter	Symbol	Min.	Typ.	Max.	Unit
Fiber core diameter	D_{core}		200		um
NA	NA		0.22		
Cladding diameter	D_{clad}		220		um

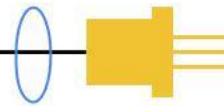

Outline Dimensions (unit: mm)

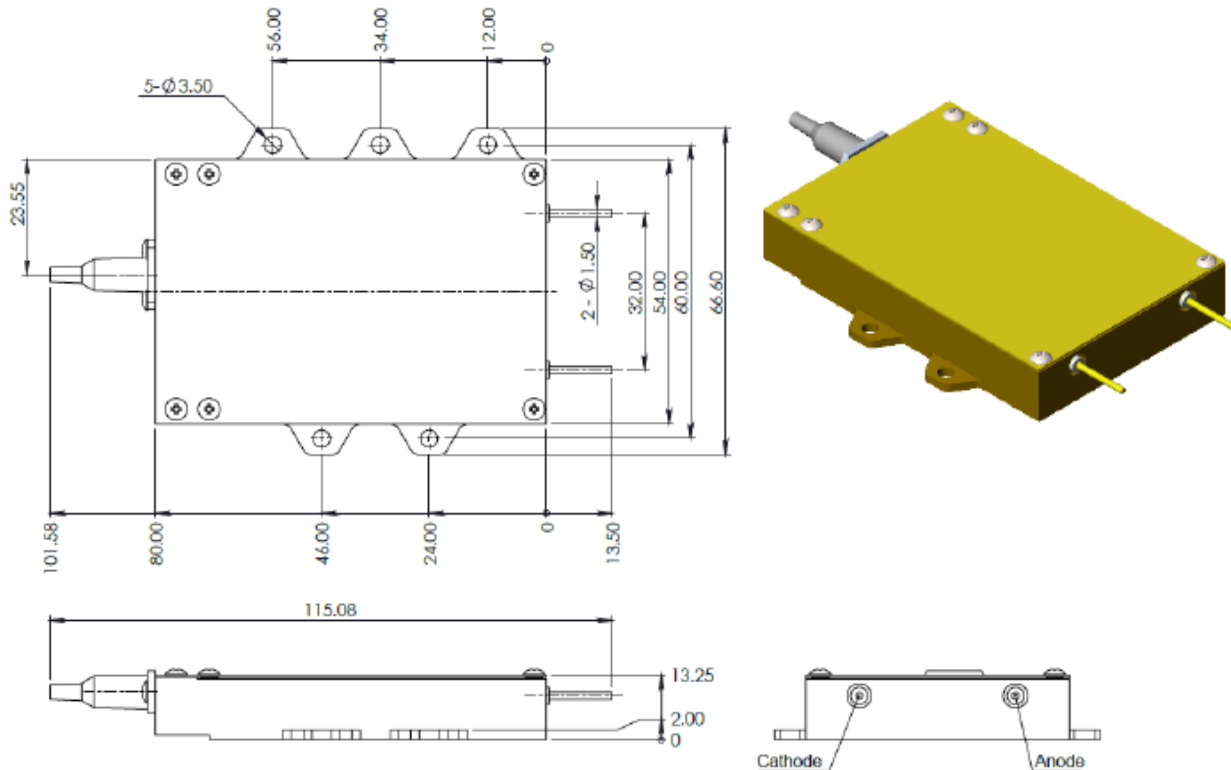

Additional Notes

- The HBFC915P200W laser diodes are designated solely as OEM components for incorporation into the customer's end products. Therefore, it is the customer's responsibility to comply with the appropriate requirements of FDA 21CFR, section 1040.10 and 1040.11 for complete laser products. For the code of FDA regulations, please refer to [FDA Performance Standards for Light-Emitting Products](#) for detailed information.
- Avoid eye and skin exposure to direct radiation during operation.
- ESD precautions must be taken during storage, transportation and operation. For ESD precaution, short-circuit is required between pins during storage and transportation.
- Soldering point should be close to the root of the pins. Soldering temperature should be lower than 260°C and time shorter than 10 seconds. Use a transformer to reduce the secondary voltage and ground the tip of the soldering iron.
- Make sure that the fiber output end is properly cleaned before operation of laser. Follow safety protocols to avoid injury when handling and cutting the fiber.
- Specifications are subject to change without notice.