



DPW473 Series 473nm CW DPSS Laser System up to 2000mW

Overview

The DPW473 series diode pumped solid state (DPSS) laser is ideal for applications that require a wavelength of 473nm and output power levels up to 2000mW. The laser features a compact design, long lifetime, easy operation, and FDA-compliant system with driver. The laser is widely used in fluorescence sensors, Raman spectrum, laser printing, holography, laser display, submarine communication, biomedicine, laser lighting show, and many other applications.



Specifications

| | | |
|--|---|---|
| Model Number | DPW473-XYZQ | |
| Wavelength (nm) | 473±1 | |
| Output power (mW) | >2000 (X=2W) | |
| Transverse mode | TEM ₀₀ | |
| Operating mode | CW | |
| Power stability (rms, over 4 hours) | <5% (Z=A), <3% (Z=E) | |
| M ² factor | <1.5 | |
| Beam diameter at aperture (1/e ² , mm) | ~3.0 | |
| Beam divergence, full angle (mrad) | <1.0 | |
| Polarization ratio | >100:1 | |
| Warm-up time (minutes) | <10 | |
| Beam height from base plate (mm) | 93.5 | |
| Operating temperature (°C) | 20-30 | |
| Dimensions of laser head (mm) | 344.5(L)×140(W) ×124.3(H) mm ³ | |
| Weight of laser head (kg) | 5.7 kg | |
| Power supply options | | |
| High Power W Version Elite Power Supply (Y=W) | Input voltage | 90-264VAC |
| | Dimensions | 307(L) ×168(W) ×123(H) mm ³ |
| | Weight | 4.5 kg |
| | Notes | Fixed output power |
| High Power W Version Laboratory Power Supply (Y=N) | Input voltage | 90-264VAC |
| | Dimensions | 336(L) ×168(W) ×133(H) mm ³ |
| | Weight | 4.6 kg |
| | Notes | Adjustable output power |
| Modulation option | None (Q=0) | |
| | TTL | 1Hz-1kHz (Q=T1), 1kHz-10kHz (Q=T2), 10kHz-30kHz (Q=T3) |
| | Analog | 1Hz-1kHz (Q=A1), 1kHz-10kHz (Q=A2), 10kHz-30kHz (Q=A3) |
| Expected lifetime (hours) | 10,000 | |
| Warranty period | 10 months | |
| FDA Compliance | FDA CDRH Title 21 CFR 1040.10/11 Class IV | |

Remarks:

- Specifications of the CW laser is based on the laser performance at full power output after the specified warmup period. The stability of output power may change when output power is adjusted at a different power level.



Outline Dimensions (unit: mm)

Laser Head

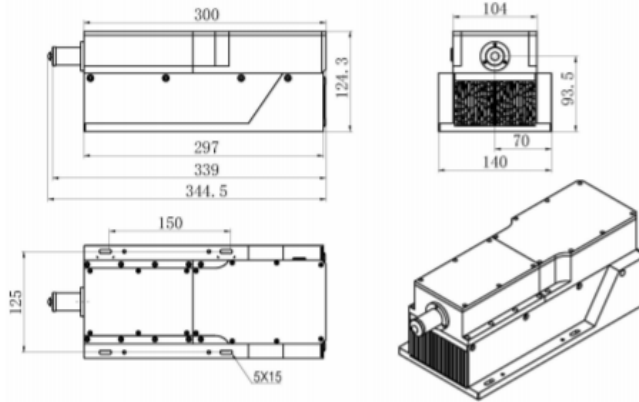

Power Supply Options

High Power W Version Elite Power Supply (Y=W)

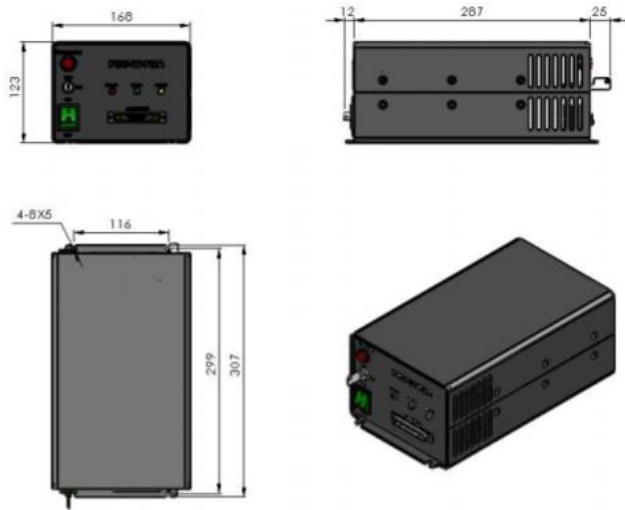

High Power W Version Laboratory Power Supply (Y=N)



Note: The above specifications are subject to change without notice.