

DPN473 Series 473nm CW DPSS Laser System up to 1500mW

Overview

The DPN473 series diode pumped solid state (DPSS) laser is ideal for applications that require a wavelength of 473nm and output power levels up to 1500mW. The laser features a compact design, long lifetime, easy operation, and FDA-compliant system with driver. The laser is widely used in collimation, laser medical treatment, scientific experiment, optical instrument, laser display, laser lighting show, and many other applications.



Specifications

Model Number	DPN473-XYZQ	
Wavelength (nm)	473±1	
Output power (mW)	>600 (X=600), >800 (X=800), >1000 (X=1W), >1500 (X=1H)	
Transverse mode	TEM ₀₀	
Operating mode	CW	
Power stability (rms, over 4 hours)	<5% (Z=A), <3% (Z=E), <2% (Z=2), <1% (Z=D)	
M ² factor	<1.5	
Beam diameter at aperture (1/e ² , mm)	~2.0	
Beam divergence, full angle (mrad)	<1.2	
Polarization ratio	>100:1	
Warm-up time (minutes)	<10	
Beam height from base plate (mm)	68.5	
Operating temperature (°C)	20-30	
Dimensions of laser head (mm)	245(L)×99(W) ×94(H) mm ³	
Weight of laser head (kg)	2.6 kg	
Power supply options		
High Power Elite Power Supply (Y=H)	Input voltage	90-264VAC
	Dimensions	307(L) ×150(W) ×106(H) mm ³
	Weight	2.9 kg
	Notes	Fixed output power
High Power Laboratory Power Supply (Y=M)	Input voltage	90-264VAC
	Dimensions	307(L) ×150(W) ×106(H) mm ³
	Weight	2.9 kg
	Notes	Adjustable output power
Modulation option	None (Q=0)	
	TTL	1Hz-1kHz (Q=T1), 1kHz-10kHz (Q=T2), 10kHz-30kHz (Q=T3)
	Analog	1Hz-1kHz (Q=A1), 1kHz-10kHz (Q=A2), 10kHz-30kHz (Q=A3)
Expected lifetime (hours)	10,000	
Warranty period	10 months	
FDA Compliance	FDA CDRH Title 21 CFR 1040.10/11 Class IV	

Remarks:

- Specifications of the CW laser is based on the laser performance at full power output after the specified warmup period. The stability of output power may change when output power is adjusted at a different power level.



Outline Dimensions (unit: mm)

Laser Head

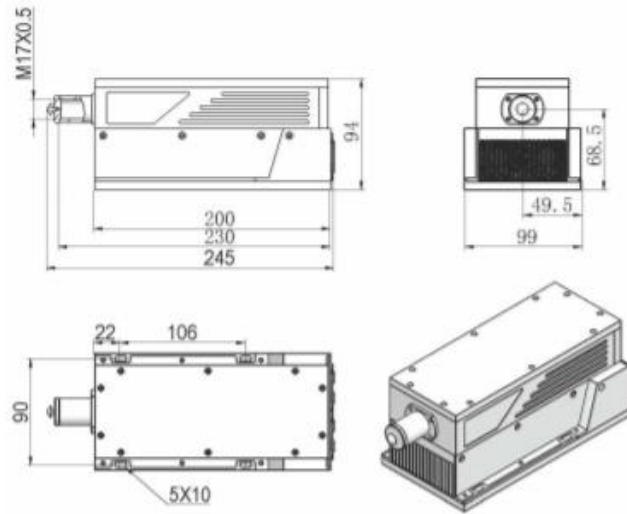

Power Supply Options

High Power Elite Power Supply (Y=H)

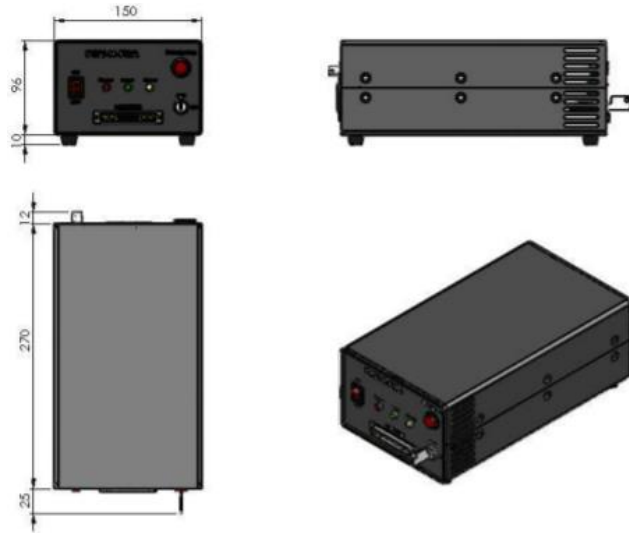

High Power Laboratory Power Supply (Y=M)

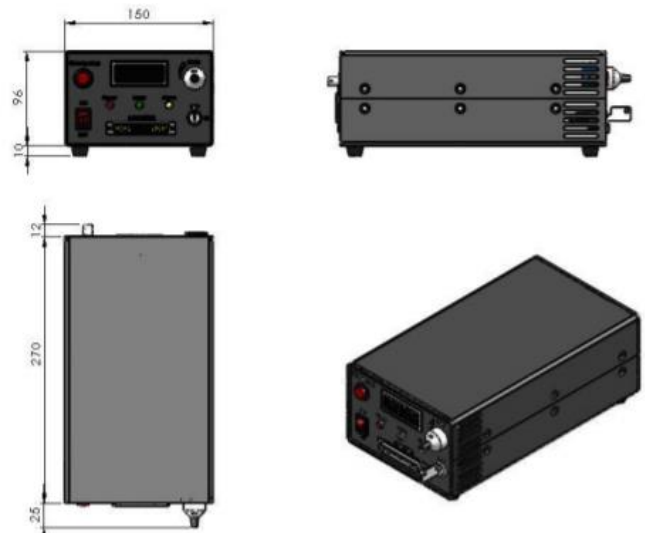

Note: The above specifications are subject to change without notice.