

DPLF532 Series 532nm Low Noise CW DPSS Laser System up to 2500mW

Overview

The DPLF532 series diode pumped solid state (DPSS) laser is ideal for applications that require a wavelength of 532nm and output power levels up to 2500mW. The laser features a compact design, low noise, long lifetime, easy operation, and FDA-compliant system with driver. The laser is widely used in DNA sequencing, flow cytometry, cell sorting, instrument, spectrum analysis, interference, measurement, holography, laser printing, chip inspection, physics experiment, and many other applications.



Specifications

Model Number	DPLF532-XYZAQ	
Wavelength (nm)	532±1	
Output power (mW)	>2000 (X=2W), >2500 (X=2H)	
Transverse mode	TEM ₀₀	
Operating mode	CW	
Power stability (rms, over 4 hours)	<5% (Z=A), <3% (Z=E), <2% (Z=2), <1% (Z=D)	
Noise of amplitude (rms, 1Hz-20MHz)	<1% (A=1), <0.5% (A=L)	
Beam diameter at aperture (mm)	~2.0	
Beam divergence, full angle (mrad)	<1.2	
M ² factor	<1.1	
Polarization ratio	>100:1	
Warm-up time (minutes)	<10	
Pointing stability after warm-up (mrad)	<0.05	
Beam height from base plate (mm)	45	
Operating temperature (°C)	10-35	
Dimensions of laser head (mm)	214(L)×88(W) ×74(H) mm ³	
Weight of laser head (kg)	1.6 kg	
Power supply options		
High Power Elite Power Supply (Y=H)	Input voltage	90-264VAC
	Dimensions	275(L) ×145(W) ×104(H) mm ³
	Weight	2.4 kg
	Notes	Fixed output power
High Power Laboratory Power Supply (Y=M)	Input voltage	90-264VAC
	Dimensions	277(L) ×145(W) ×106(H) mm ³
	Weight	2.6 kg
	Notes	Adjustable output power
Modulation option		None (Q=0)
	TTL	1Hz-1kHz (Q=T1), 1kHz-10kHz (Q=T2), 10kHz-30kHz (Q=T3)
	Analog	1Hz-1kHz (Q=A1), 1kHz-10kHz (Q=A2), 10kHz-30kHz (Q=A3)
Expected lifetime (hours)	10,000	
Warranty period	10 months	
FDA Compliance	FDA CDRH Title 21 CFR 1040.10/11 Class IV	

Remarks:

- Specifications of the CW laser is based on the laser performance at full power output after the specified warmup period. The stability of output power may change when output power is adjusted at a different power level.



Outline Dimensions (unit: mm)

Laser Head

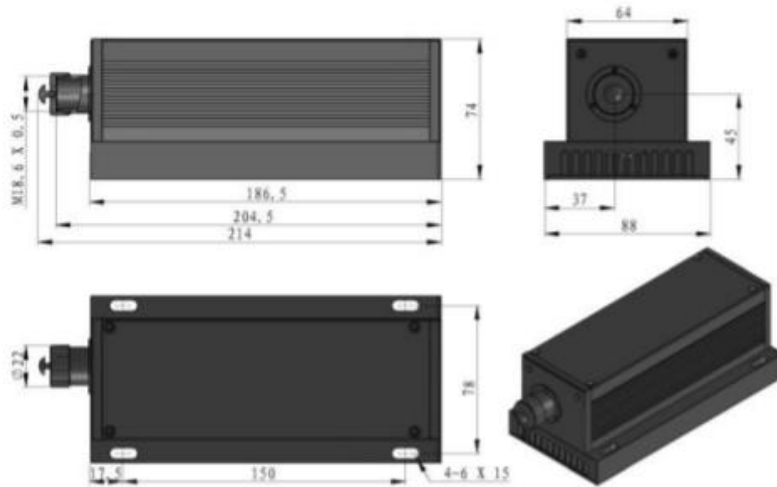

Power Supply Options

High Power Elite Power Supply (Y=H)

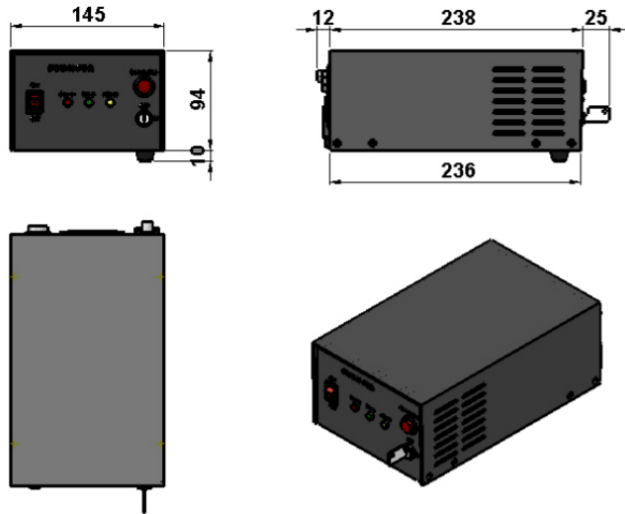

High Power Laboratory Power Supply (Y=M)



Note: The above specifications are subject to change without notice.