

DPL1444 Series 1444nm Low Noise CW DPSS Laser System up to 400mW

Overview

The DPL1444 series diode pumped solid state (DPSS) laser is ideal for applications that require a wavelength of 1444nm and output power levels up to 400mW. The laser features low noise, compact design, long lifetime, easy operation, and FDA-compliant system with driver. The laser is widely used in scientific experiment, measurement, optical sensor, measurement, spectrum analysis, optical instrument, communication, and many other applications.



Specifications

Model Number	DPL1444-XYZA		
Wavelength (nm)	1444±2		
Output power (mW)	>50 (X=50), >80 (X=80), >100 (X=100), >200 (X=200)	>300 (X=300), >400 (X=400)	
Transverse mode	Near TEM ₀₀		
Operating mode	CW		
Power stability (rms, over 4 hours)	<5% (Z=A), <3% (Z=E), <2% (Z=2)	<5% (Z=A), <3% (Z=E)	
Noise of amplitude (rms, 20Hz-20MHz)	<1% (A=1)		
M ² factor	<1.5		
Beam diameter at aperture (1/e ² , mm)	~1.5		
Beam divergence, full angle (mrad)	<1.5		
Warm-up time (minutes)	<10		
Beam height from base plate (mm)	24.8		
Pointing stability after warm-up (mrad)	<0.05		
Operating temperature (°C)	10-35		
Dimensions of laser head (mm)	140.5(L)×73(W) ×46.2(H) mm ³		
Weight of laser head (kg)	0.6 kg		
Power supply options			
Elite Power Supply (Y=E)	Input voltage	90-264VAC	
	Dimensions	171(L) ×130(W) ×62.2(H) mm ³	
	Weight	1.2 kg	
	Notes	Fixed output power	
Laboratory Power Supply (Y=L)	Input voltage	90-264VAC	
	Dimensions	188.6(L) ×155(W) ×92(H) mm ³	
	Weight	1.5 kg	
	Notes	Adjustable output power	
Modulation option		None (Q=0)	
	TTL	1Hz-1kHz (Q=T1), 1kHz-10kHz (Q=T2), 10kHz-30kHz (Q=T3)	
	Analog	1Hz-1kHz (Q=A1), 1kHz-10kHz (Q=A2), 10kHz-30kHz (Q=A3)	
Expected lifetime (hours)	10,000		
Warranty period	10 months		
FDA Compliance	FDA CDRH Title 21 CFR 1040.10/11 Class IIIb		

Remarks:

- Specifications of the CW laser is based on the laser performance at full power output after the specified warmup period. The stability of output power may change when output power is adjusted at a different power level.

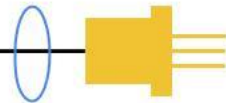

Outline Dimensions (unit: mm)

Laser Head

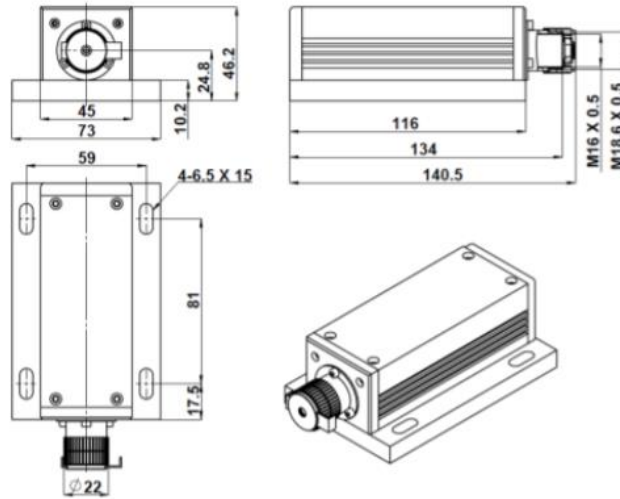

Power Supply Options

Elite Power Supply (Y=E)

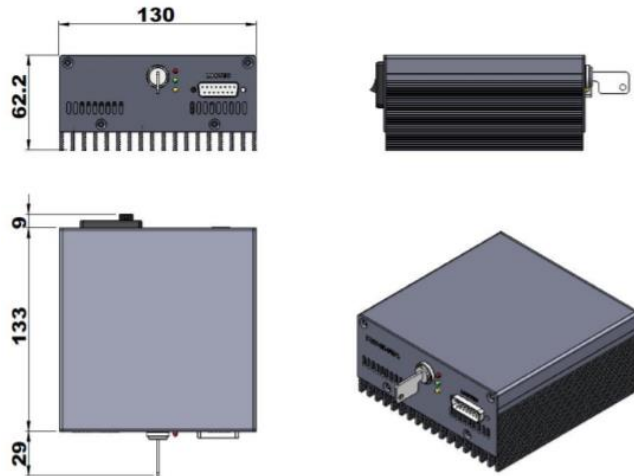

Laboratory Power Supply (Y=L)

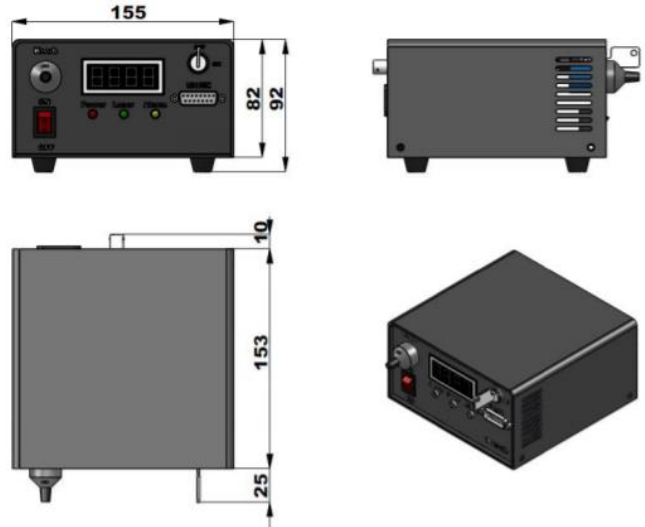

Note: The above specifications are subject to change without notice.