



## DPH1413 Series 1413nm CW DPSS Laser System up to 300mW

### Overview

The DPH1413 series diode pumped solid state (DPSS) laser is ideal for applications that require a wavelength of 1413nm and output power levels up to 300mW. The laser features a compact design, long lifetime, easy operation, and FDA-compliant system with driver. The laser is widely used in scientific experiment, optical instrument, optical sensor, measurement, communication, spectrum analysis, and many other applications.



### Specifications

<b>Model Number</b>	<b>DPH1413-XYZQ</b>	
Wavelength (nm)	1413±2	
Output power (mW)	>50 ( <b>X=50</b> ), >80 ( <b>X=80</b> ), >100 ( <b>X=100</b> ), >200 ( <b>X=200</b> ), >300 ( <b>X=300</b> )	
Transverse mode	Near TEM <sub>00</sub>	
Operating mode	CW	
Power stability (rms, over 4 hours)	<10% ( <b>Z=B</b> ), <5% ( <b>Z=A</b> ), <3% ( <b>Z=E</b> )	
M <sup>2</sup> factor	<15	
Beam diameter at aperture (1/e <sup>2</sup> , mm)	~1.5	
Beam divergence, full angle (mrad)	<1.5	
Warm-up time (minutes)	<10	
Pointing stability after warm-up (mrad)	<0.05	
Beam height from base plate (mm)	29	
Operating temperature (°C)	10-35	
Dimensions of laser head (mm)	154.5(L)×77(W) ×60(H) mm <sup>3</sup>	
Weight of laser head (kg)	0.9 kg	
Power supply options		
High Power Elite Power Supply ( <b>Y=H</b> )	Input voltage	90-264VAC
	Dimensions	275(L) ×145(W) ×104(H) mm <sup>3</sup>
	Weight	2.3 kg
	Notes	Fixed output power
High Power Laboratory Power Supply ( <b>Y=M</b> )	Input voltage	90-264VAC
	Dimensions	277(L) ×145(W) ×106(H) mm <sup>3</sup>
	Weight	2.6 kg
	Notes	Adjustable output power
Modulation option	None ( <b>Q=0</b> )	
	TTL	1Hz-1kHz ( <b>Q=T1</b> ), 1kHz-10kHz ( <b>Q=T2</b> ), 10kHz-30kHz ( <b>Q=T3</b> )
	Analog	1Hz-1kHz ( <b>Q=A1</b> ), 1kHz-10kHz ( <b>Q=A2</b> ), 10kHz-30kHz ( <b>Q=A3</b> )
Expected lifetime (hours)	10,000	
Warranty period	10 months	
FDA Compliance	FDA CDRH Title 21 CFR 1040.10/11 Class IV	

### Remarks:

- Specifications of the CW laser is based on the laser performance at full power output after the specified warmup period. The stability of output power may change when output power is adjusted at a different power level.



**Outline Dimensions (unit: mm)**

**Laser Head**

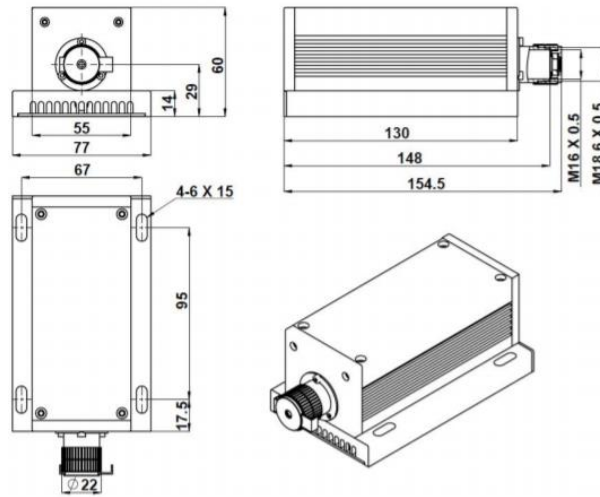

**Power Supply Options**

**High Power Elite Power Supply (Y=H)**

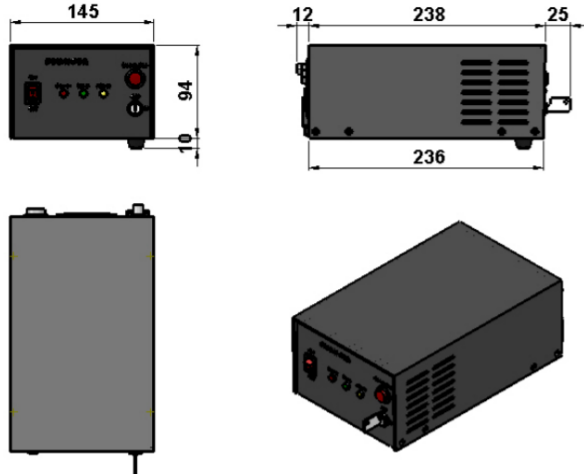

**High Power Laboratory Power Supply (Y=M)**



Note: The above specifications are subject to change without notice.