



DPFN604 Series 604nm Fan-less CW DPSS Laser System up to 100mW

Overview

The DPFN604 series diode pumped solid state (DPSS) laser is ideal for applications that require a wavelength of 604nm and output power levels up to 100mW. The laser features compact design, long lifetime, easy operating, and FDA-compliant system with driver. The laser is widely used in measurement, spectrum analysis, and as substitute for He-Ne lasers.



Specifications

Model Number	DPFN604-XYZQ	
Wavelength (nm)	604±3	
Output power (mW)	>10 (X=10), >30 (X=30), >50 (X=50), >80 (X=80), >100 (X=100)	
Transverse mode	TEM ₀₀	
Operating mode	CW	
Power stability (rms, over 4 hours)	<10% (Z=B), <5% (Z=A), <3% (Z=E)	
Beam diameter at aperture (mm)	~1.0	
Beam divergence, full angle (mrad)	<1.5	
Warm-up time (minutes)	<5	
Beam height from base plate (mm)	27.4	
Operating temperature (°C)	10-35	
Dimensions of laser head (mm)	197(L)×70(W) ×50(H) mm ³	
Weight of laser head (kg)	1.36 kg	
Power supply options		
High Power Elite Power Supply (Y=H)	Input voltage	90-264VAC
	Dimensions	275(L) ×145(W) ×104(H) mm ³
	Weight	2.3 kg
	Notes	Fixed output power
High Power Laboratory Power Supply (Y=M)	Input voltage	90-264VAC
	Dimensions	277(L) ×145(W) ×106(H) mm ³
	Weight	2.6 kg
	Notes	Adjustable output power
High Power S Version Laboratory Power Supply (Y=S)	Input voltage	90-264VAC
	Dimensions	188(L) ×145(W) ×83(H) mm ³
	Weight	2 kg
	Notes	Adjustable output power
Modulation option	None (Q=0)	
	TTL	1Hz-1kHz (Q=T1), 1kHz-10kHz (Q=T2), 10kHz-30kHz (Q=T3)
	Analog	1Hz-1kHz (Q=A1), 1kHz-10kHz (Q=A2), 10kHz-30kHz (Q=A3)
Expected lifetime (hours)	10,000	
Warranty period	10 months	
FDA Compliance	FDA CDRH Title 21 CFR 1040.10/11 Class IIIb	

Remarks:

- The laser head needs to be used on a heat sink with good heat dissipation.
- Specifications of the CW laser is based on the laser performance at full power output after the specified warmup period. The stability of output power may change when output power is adjusted at a different power level.



Outline Dimensions (unit: mm)

Laser Head

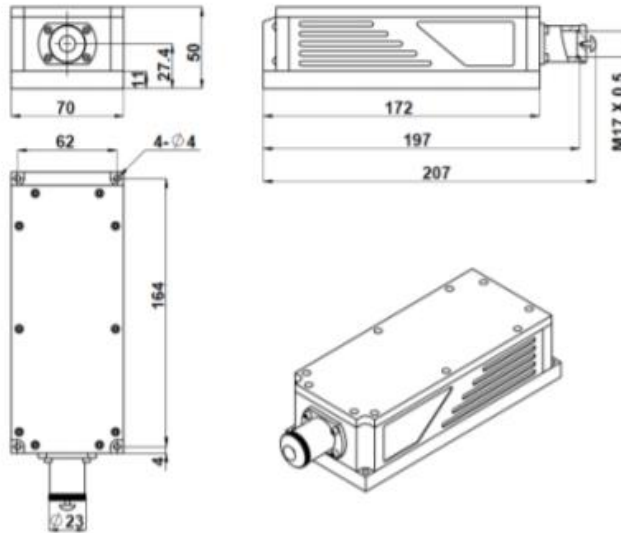

Power Supply Options

High Power Elite Power Supply (Y=H)

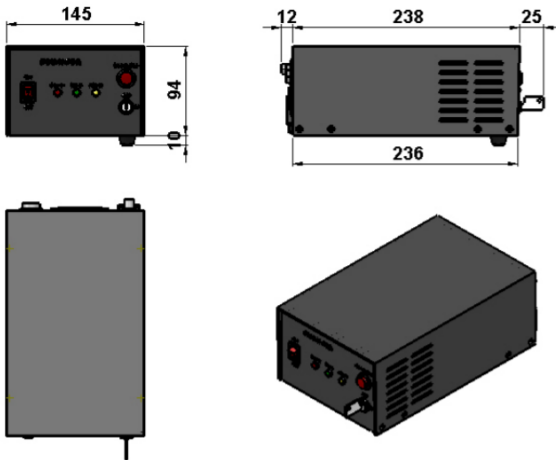

High Power Laboratory Power Supply (Y=M)



High Power S Version Laboratory Power Supply (Y=S)



Note: The above specifications are subject to change without notice.