

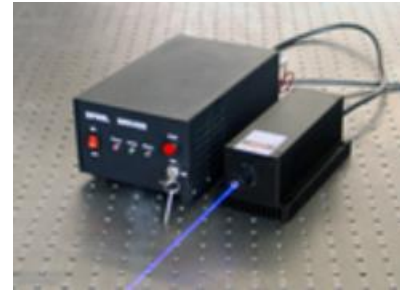

## DPF457 Series 457nm CW DPSS Laser System up to 1000mW

### Overview

The DPF457 series diode pumped solid state (DPSS) laser is ideal for applications that require a wavelength of 457nm and output power levels up to 1000mW. The laser features a compact design, long lifetime, easy operation, and FDA-compliant system with driver. The laser is widely used in fluorescence sensors, Raman spectrum, laser printing, holography, laser display, submarine communication, biomedicine, laser lighting show, and many other applications.



### Specifications

<b>Model Number</b>	<b>DPF457-XYZQ</b>		
Wavelength (nm)	457±1		
Output power (mW)	>50 ( <b>X=50</b> ), >100 ( <b>X=100</b> ), >300 ( <b>X=300</b> )	>500 ( <b>X=500</b> ), >800 ( <b>X=800</b> ), >1000 ( <b>X=1W</b> )	
Transverse mode	Near TEM <sub>00</sub>	Near TEM <sub>01</sub>	
Operating mode	CW		
Power stability (rms, over 4 hours)	<10% ( <b>Z=B</b> ), <5% ( <b>Z=A</b> ), <3% ( <b>Z=E</b> )	<10% ( <b>Z=B</b> ), <5% ( <b>Z=A</b> )	
M <sup>2</sup> factor	<2.0		
Beam diameter at aperture (1/e <sup>2</sup> , mm)	~3.0		
Beam divergence, full angle (mrad)	<1.5		
Polarization ratio	>100:1		
Warm-up time (minutes)	<10		
Pointing stability after warm-up (mrad)	<0.05		
Beam height from base plate (mm)	45		
Operating temperature (°C)	10-35		
Dimensions of laser head (mm)	211(L)x88(W) x74(H) mm <sup>3</sup>		
Weight of laser head (kg)	1.6 kg		
Power supply options			
High Power Elite Power Supply ( <b>Y=H</b> )	Input voltage	90-264VAC	
	Dimensions	236(L) x145(W) x104(H) mm <sup>3</sup>	
	Weight	2.3 kg	
	Notes	Fixed output power	
High Power Laboratory Power Supply ( <b>Y=M</b> )	Input voltage	90-264VAC	
	Dimensions	277(L) x145(W) x106(H) mm <sup>3</sup>	
	Weight	2.6 kg	
	Notes	Adjustable output power	
High Power S Version Laboratory Power Supply ( <b>Y=S</b> )	Input voltage	90-264VAC	
	Dimensions	188(L) x145(W) x83(H) mm <sup>3</sup>	
	Weight	2 kg	
	Notes	Adjustable output power	
Modulation option		None ( <b>Q=0</b> )	
	TTL	1Hz-1kHz ( <b>Q=T1</b> ), 1kHz-10kHz ( <b>Q=T2</b> ), 10kHz-30kHz ( <b>Q=T3</b> )	
	Analog	1Hz-1kHz ( <b>Q=A1</b> ), 1kHz-10kHz ( <b>Q=A2</b> ), 10kHz-30kHz ( <b>Q=A3</b> )	
Expected lifetime (hours)	10,000		
Warranty period	10 months		
FDA Compliance	FDA CDRH Title 21 CFR 1040.10/11 Class IV		

#### Remarks:

- Specifications of the CW laser is based on the laser performance at full power output after the specified warmup period. The stability of output power may change when output power is adjusted at a different power level.



**Outline Dimensions (unit: mm)**

**Laser Head**

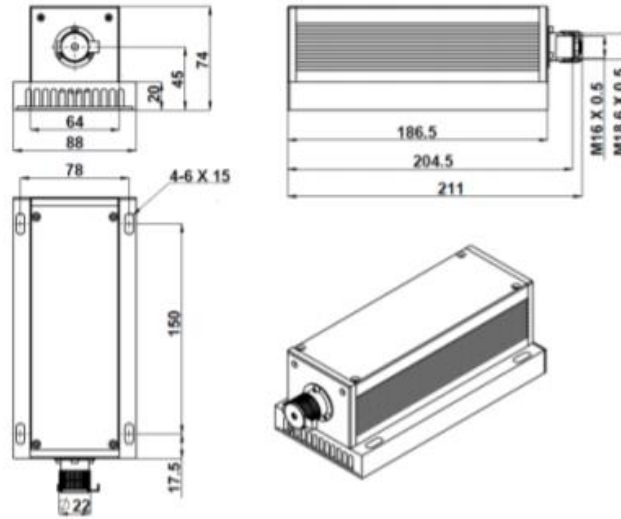

**Power Supply Options**

**High Power Elite Power Supply (Y=H)**

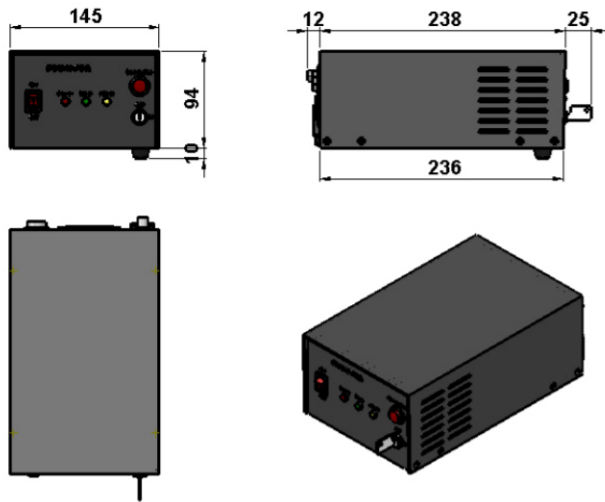

**High Power Laboratory Power Supply (Y=M)**



**High Power S Version Laboratory Power Supply (Y=S)**



Note: The above specifications are subject to change without notice.