

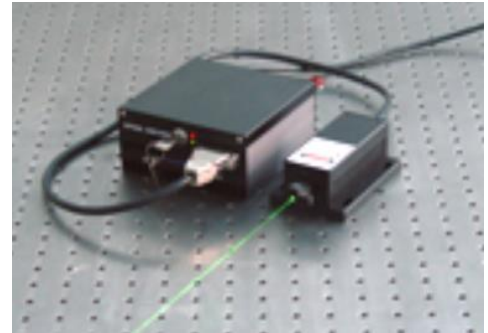

DP532 Series 532nm CW DPSS Laser System up to 300mW

Overview

The DP532 series diode pumped solid state (DPSS) laser is ideal for applications that require a wavelength of 532nm and output power levels up to 300mW. The laser features a compact design, long lifetime, easy operation, and FDA-compliant system with driver. The laser is widely used in collimation, laser medical treatment, scientific experiment, optical instrument, laser display, laser lighting show, and many other applications.



Specifications

Model Number	DP532-XYZQ		
Wavelength (nm)	532±1		
Output power (mW)	>100 (X=100), >200 (X=200)	>300 (X=300)	
Transverse mode	TEM ₀₀		
Operating mode	CW		
Power stability (rms, over 4 hours)	<3% (Z=E), <2% (Z=2), <1% (Z=D)	<3% (Z=E), <2% (Z=2)	
M ² factor	<1.2		
Beam diameter at aperture (1/e ² , mm)	~1.2		
Beam divergence, full angle (mrad)	<1.2		
Polarization ratio	>100:1 Horizontal ±5 degree		
Warm-up time (minutes)	<10		
Beam height from base plate (mm)	24.8		
Pointing stability after warm-up (mrad)	<0.05		
Operating temperature (°C)	10-35		
Dimensions of laser head (mm)	140.5(L)×73(W) ×46.2(H) mm ³		
Weight of laser head (kg)	0.6 kg		
Power supply options			
Elite Power Supply (Y=E)	Input voltage	90-264VAC	
	Dimensions	133(L) ×130(W) ×62.2(H) mm ³	
	Weight	1.2 kg	
	Notes	Fixed output power	
Laboratory Power Supply (Y=L)	Input voltage	90-264VAC	
	Dimensions	153(L) ×155(W) ×92(H) mm ³	
	Weight	1.5 kg	
	Notes	Adjustable output power	
Modulation option		None (Q=0)	
	TTL	1Hz-1kHz (Q=T1), 1kHz-10kHz (Q=T2), 10kHz-30kHz (Q=T3)	
	Analog	1Hz-1kHz (Q=A1), 1kHz-10kHz (Q=A2), 10kHz-30kHz (Q=A3)	
Expected lifetime (hours)	10,000		
Warranty period	10 months		
FDA Compliance	FDA CDRH Title 21 CFR 1040.10/11 Class IIIb		

Remarks:

- Specifications of the CW laser is based on the laser performance at full power output after the specified warmup period. The stability of output power may change when output power is adjusted at a different power level.



Outline Dimensions (unit: mm)

Laser Head

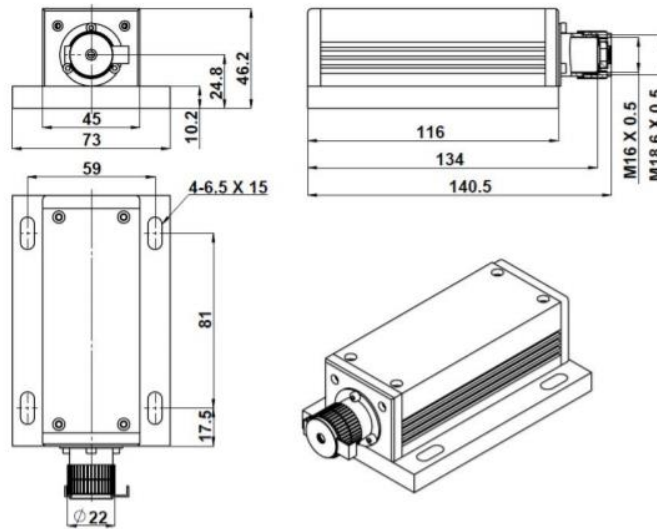

Power Supply Options

Elite Power Supply (Y=E)

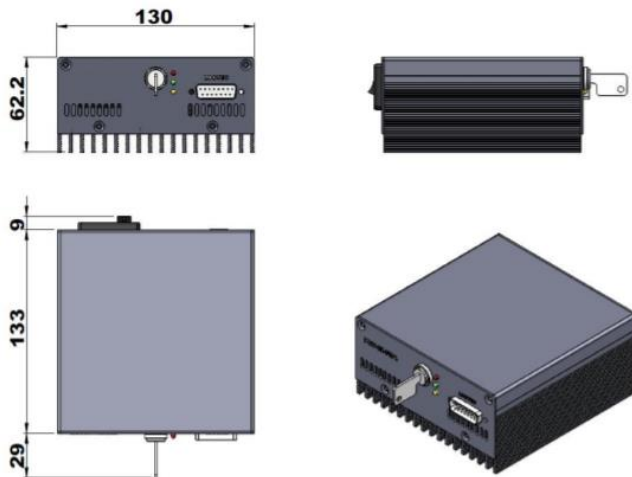

Laboratory Power Supply (Y=L)

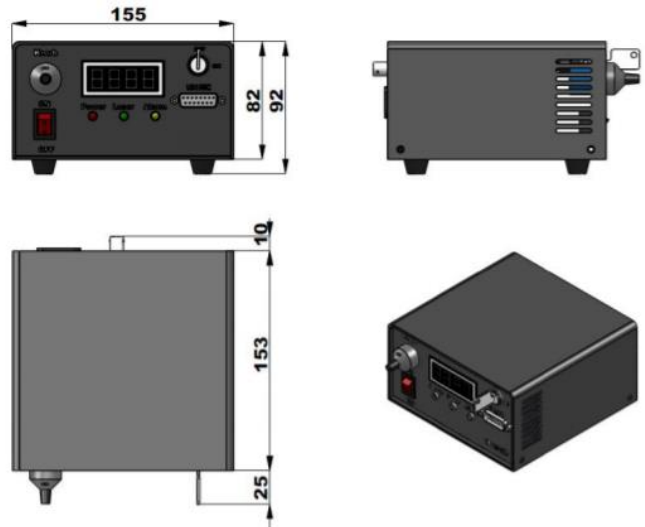

Note: The above specifications are subject to change without notice.