



## DLL915 Series 915nm Low Noise Diode Laser System up to 1500mW

### Overview

The DLL915 series diode laser is ideal for applications that require a wavelength of 915nm and output power levels up to 1500mW. The laser features low noise, compact design, long operating lifetime, easy operation, and FDA-compliant system with driver. The laser is widely used in measurement, communication, spectrum analysis, and many other applications.



### Specifications

<b>Model Number</b>	<b>DLL915-XYPZQ</b>	
Wavelength (nm)	915±5	
Output power (mW)	>500 ( <b>X=500</b> ), >1000 ( <b>X=1W</b> ), >1500 ( <b>X=1H</b> )	
Transverse mode	Multimode	
Operating mode	CW	
Power stability (rms, over 4 hours)	<1% ( <b>P=D</b> )	
Noise of amplitude (rms, 20Hz-20MHz)	<1% ( <b>Z=1</b> )	
Beam diameter at aperture (1/e <sup>2</sup> , mm)	~5x8	
Beam divergence, full angle (mrad)	<3.0	
Warm-up time (minutes)	<5	
Beam height from base plate (mm)	24.8	
Operating temperature (°C)	10-35	
Dimensions of laser head (mm)	146(L)x73(W) x46.2(H) mm <sup>3</sup>	
Weight of laser head (kg)	0.7 kg	
Power supply options		
Elite Power Supply ( <b>Y=E</b> )	Input voltage	85-264VAC
	Dimensions	171(L) x130(W) x62.2(H) mm <sup>3</sup>
	Weight	1.2 kg
	Notes	Fixed output power, frequency 1Hz-30kHz
Laboratory Power Supply ( <b>Y=L</b> )	Input voltage	85-264VAC
	Dimensions	188.6(L) x155(W) x92(H) mm <sup>3</sup>
	Weight	1.5 kg
	Notes	Adjustable output power, frequency 1Hz-30kHz
A Version Laboratory Power Supply ( <b>Y=T</b> )	Input voltage	100-240VAC
	Dimensions	162(L) x144(W) x70(H) mm <sup>3</sup>
	Weight	1.0 kg
	Notes	Adjustable output power, LCD display, frequency 30kHz-100kHz
Modulation option		None ( <b>Q=0</b> )
	TTL	1Hz-1kHz ( <b>Q=T1</b> ), 1kHz-10kHz ( <b>Q=T2</b> ), 10kHz-30kHz ( <b>Q=T3</b> ), 30kHz-100kHz ( <b>Q=T4</b> )
	Analog	1Hz-1kHz ( <b>Q=A1</b> ), 1kHz-10kHz ( <b>Q=A2</b> ), 10kHz-30kHz ( <b>Q=A3</b> ), 30kHz-100kHz ( <b>Q=A4</b> )
Expected lifetime (hours)	10,000	
Warranty period	10 months	
FDA Compliance	FDA CDRH Title 21 CFR 1040.10/11 Class IV	

### Remarks:

- Specifications of the CW laser is based on the laser performance at full power output after the specified warmup period. The stability of output power may change when output power is adjusted at a different power level.



**Outline Dimensions (unit: mm)**

**Laser Head**

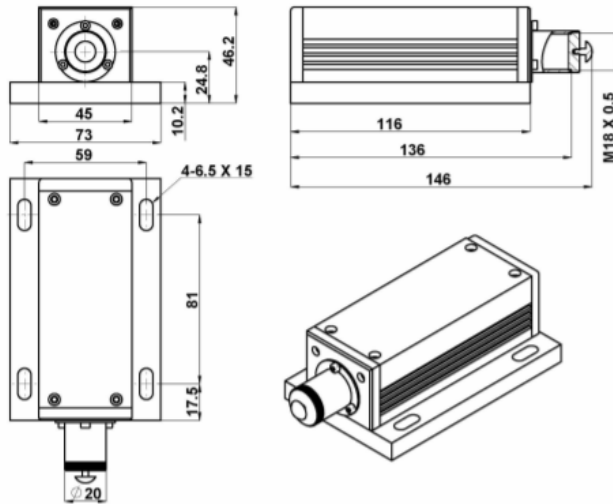

**Power Supply Options**

**Elite Power Supply (Y=E)**

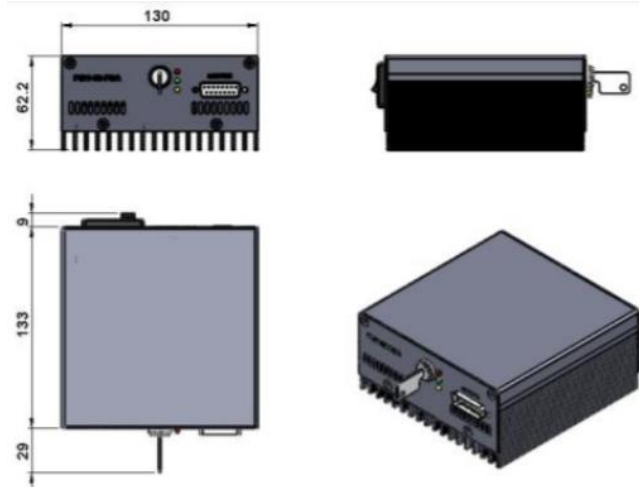

**Laboratory Power Supply (Y=L)**

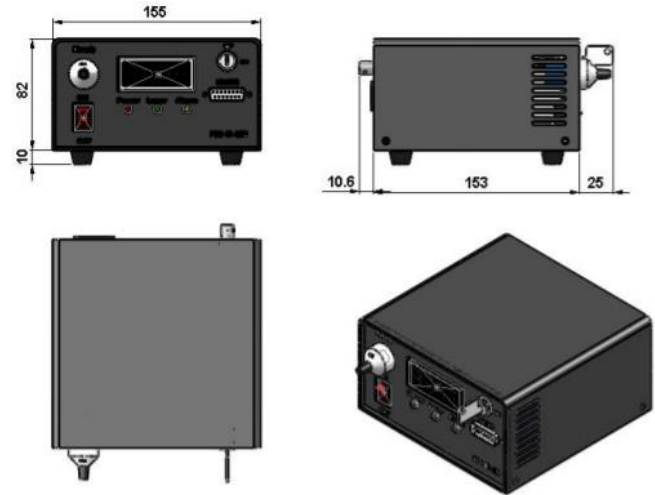

**A Version Laboratory Power Supply (Y=T)**

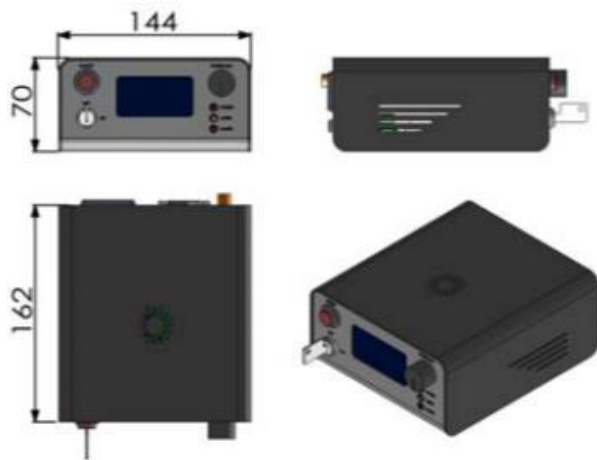

Note: The above specifications are subject to change without notice.

**Lasermate Group, Inc.**

19608 Camino De Rosa, Walnut, CA 91789, USA

Tel: (909)718-0999 | Fax: (909)718-0998 | E-mail: [info@lasermate.com](mailto:info@lasermate.com) | URL: <http://www.lasermate.com>