

DLL730 Series 730nm Low Noise Diode Laser System up to 1500mW

Overview

The DLL730 series diode laser is ideal for applications that require a wavelength of 730nm and output power levels up to 1500mW. The laser features low noise, compact design, long operating lifetime, easy operation, and FDA-compliant system with driver. The laser is widely used in measurement, spectrum analysis, and many other applications.



Specifications

Model Number	DLL730H-XYPZQ		DLL730-XYPZQ	
Wavelength (nm)	730±10		730±5	
Output power (mW)	>10 (X=10), >20 (X=20), >30 (X=30)		>100 (X=100), >300 (X=300), >1000 (X=1W), >1500 (X=1H)	
Transverse mode	Near TEM ₀₀		Multimode	
Operating mode	CW			
Power stability (rms, over 4 hours)	<1% (P=D), <0.5% (P=S)			
Noise of amplitude (rms, 20Hz-20MHz)	<1% (Z=1)			
Beam diameter at aperture (1/e ² , mm)	~3.0		~5x8	
Beam divergence, full angle (mrad)	<1.0		<3	
Warm-up time (minutes)	<5			
Beam height from base plate (mm)	24.8			
Operating temperature (°C)	10-35			
Dimensions of laser head (mm)	143.5(L)x73(W) x46.2(H) mm ³		146(L)x73(W) x46.2(H) mm ³	
Weight of laser head (kg)	0.7 kg		0.7 kg	
Power supply options				
Elite Power Supply (Y=E)	Input voltage	85-264VAC		
	Dimensions	171(L) x130(W) x62.2(H) mm ³		
	Weight	1.2 kg		
	Notes	Fixed output power, frequency 1Hz-30kHz		
Laboratory Power Supply (Y=L)	Input voltage	85-264VAC		
	Dimensions	188.6(L) x155(W) x92(H) mm ³		
	Weight	1.5 kg		
	Notes	Adjustable output power, frequency 1Hz-30kHz		
A Version Laboratory Power Supply (Y=T)	Input voltage	100-240VAC		
	Dimensions	162(L) x144(W) x70(H) mm ³		
	Weight	1.0 kg		
	Notes	Adjustable output power, LCD display, frequency 30kHz-100kHz		
Modulation option		None (Q=0)		
	TTL	1Hz-1kHz (Q=T1), 1kHz-10kHz (Q=T2), 10kHz-30kHz (Q=T3), 30kHz-100kHz (Q=T4)		
	Analog	1Hz-1kHz (Q=A1), 1kHz-10kHz (Q=A2), 10kHz-30kHz (Q=A3), 30kHz-100kHz (Q=A4)		
Expected lifetime (hours)	10,000			
Warranty period	10 months			
FDA Compliance	FDA CDRH Title 21 CFR 1040.10/11 Class IIIb		FDA CDRH Title 21 CFR 1040.10/11 Class IV	

Remarks:

- Specifications of the CW laser is based on the laser performance at full power output after the specified warmup period. The stability of output power may change when output power is adjusted at a different power level.

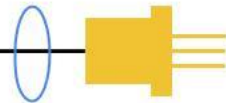

Outline Dimensions (unit: mm)

Laser Head

For DLL730H

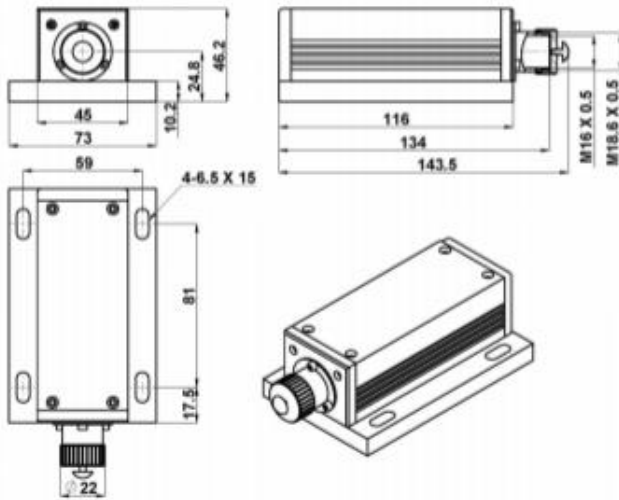

For DLL730

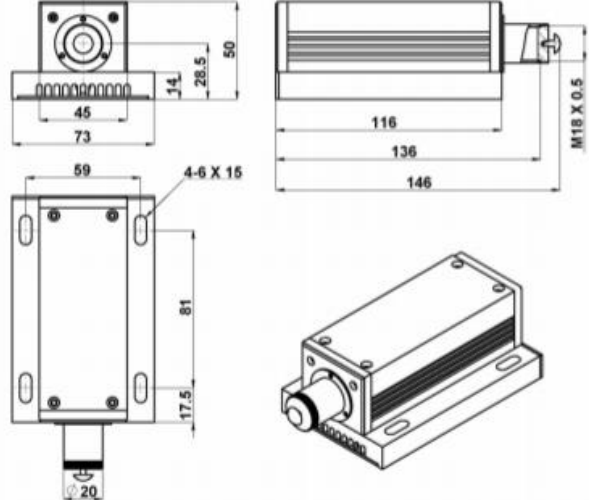

Power Supply Options

Elite Power Supply (Y=E)

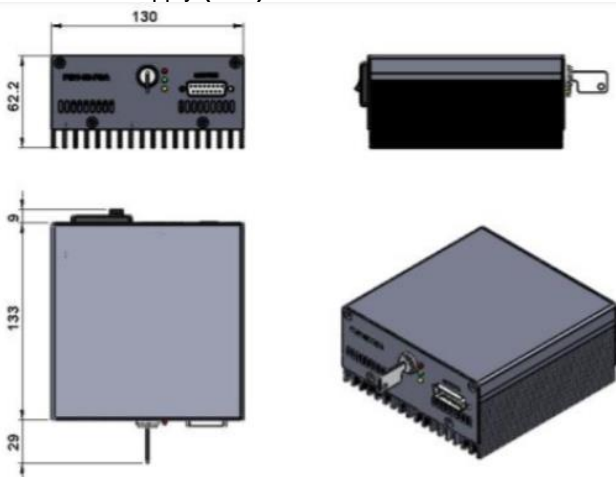

Laboratory Power Supply (Y=L)

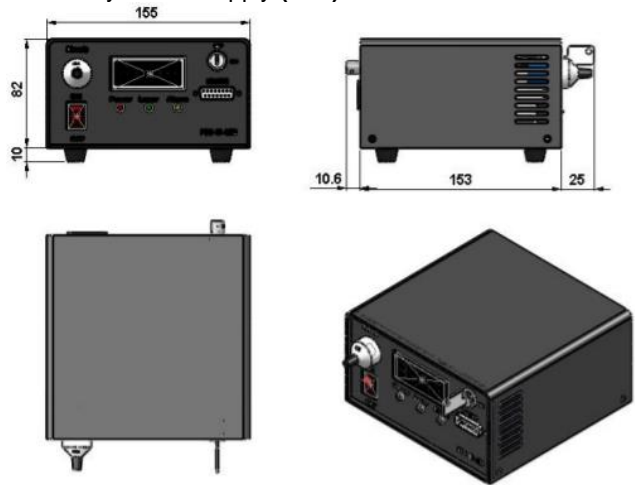

A Version Laboratory Power Supply (Y=T)

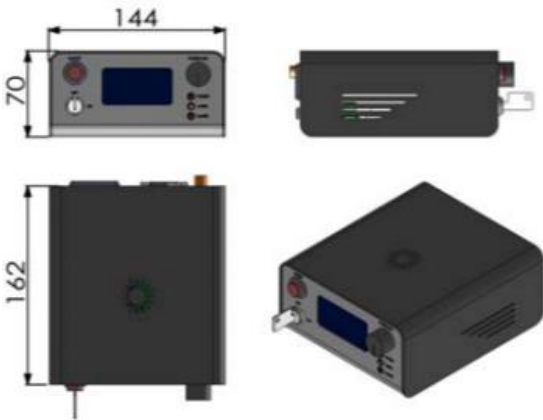

Note: The above specifications are subject to change without notice.