

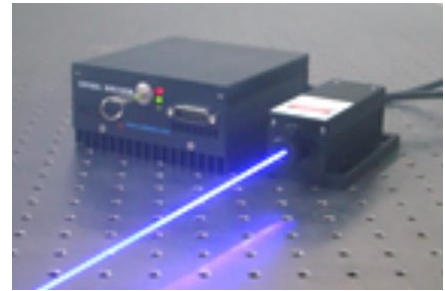

DLL400 Series 400nm Low Noise Diode Laser System up to 300mW

Overview

The DLL400 series low noise diode laser is ideal for applications that require a wavelength of 400nm and output power levels up to 300mW. The laser features a compact design, low noise, long operating lifetime, easy operation, and FDA-compliant system with driver. The laser is widely used in measurement, communication, spectrum analysis, and many other applications.



Specifications

Model Number	DLL400-XYPZQ	
Wavelength (nm)	400±5	
Output power (mW)	>50 (X=50), >100 (X=100), >150 (X=150), >200 (X=200), >250 (X=250), >300 (X=300)	
Transverse mode	Near TEM ₀₀	
Operating mode	CW	
Power stability (rms, over 4 hours)	<1% (P=D), <0.5% (P=S)	
Noise of amplitude (rms, 20Hz-20MHz)	<1% (Z=1)	
M ² factor	<1.5	
Beam diameter at aperture (1/e ² , mm)	~2.5	
Beam divergence, full angle (mrad)	0.5	
Polarization ratio	>50:1 Horizontal ±5 degree	
Warm-up time (minutes)	<5	
Pointing stability after warm-up (mrad)	<0.05	
Beam height from base plate (mm)	24.8	
Operating temperature (°C)	10-35	
Dimensions of laser head (mm)	143.5(L)×73(W) ×46.2(H) mm ³	
Weight of laser head (kg)	0.7 kg	
Power supply options		
Elite Power Supply (Y=E)	Input voltage	85-264VAC
	Dimensions	171(L) ×130(W) ×62.2(H) mm ³
	Weight	1.2 kg
	Notes	Fixed output power, frequency 1Hz-30kHz
Laboratory Power Supply (Y=L)	Input voltage	85-264VAC
	Dimensions	188.6(L) ×155(W) ×92(H) mm ³
	Weight	1.5 kg
	Notes	Adjustable output power, frequency 1Hz-30kHz
A Version Laboratory Power Supply (Y=T)	Input voltage	100-240VAC
	Dimensions	162(L) ×144(W) ×70(H) mm ³
	Weight	1.0 kg
	Notes	Adjustable output power, LCD display, frequency 30kHz-100kHz
Modulation option	None (Q=0)	
	TTL	1Hz-1kHz (Q=T1), 1kHz-10kHz (Q=T2), 10kHz-30kHz (Q=T3), 30kHz-100kHz (Q=T4)
	Analog	1Hz-1kHz (Q=A1), 1kHz-10kHz (Q=A2), 10kHz-30kHz (Q=A3), 30kHz-100kHz (Q=A4)
Expected lifetime (hours)	10,000	
Warranty period	10 months	
FDA Compliance	FDA CDRH Title 21 CFR 1040.10/11 Class IIIb	

Remarks:

- Specifications of the CW laser is based on the laser performance at full power output after the specified warmup period. The stability of output power may change when output power is adjusted at a different power level.



Outline Dimensions (unit: mm)

Laser Head

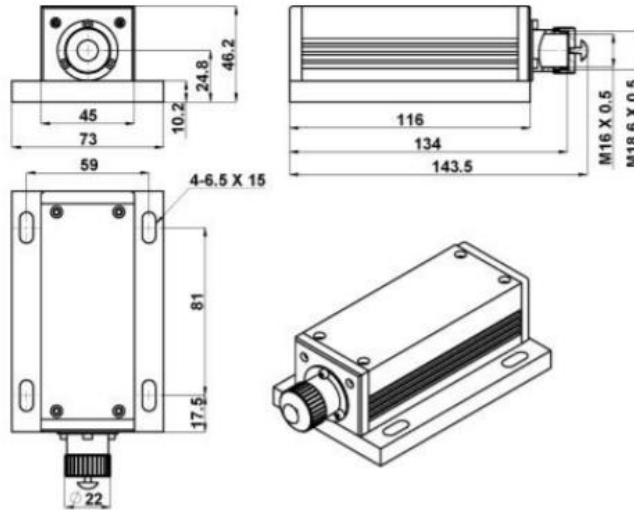

Power Supply Options

Elite Power Supply (Y=E)

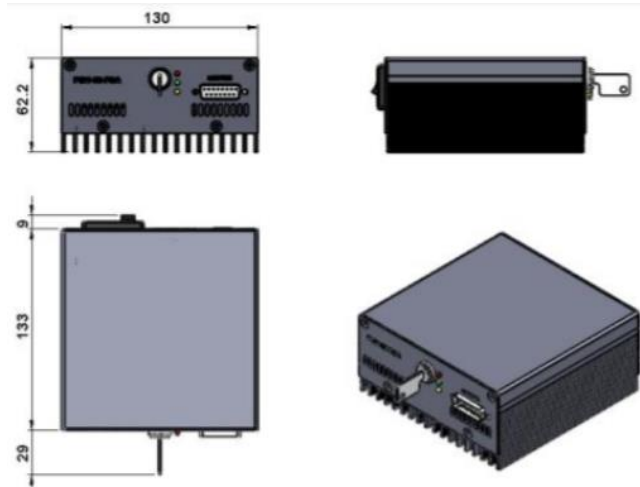

Laboratory Power Supply (Y=L)

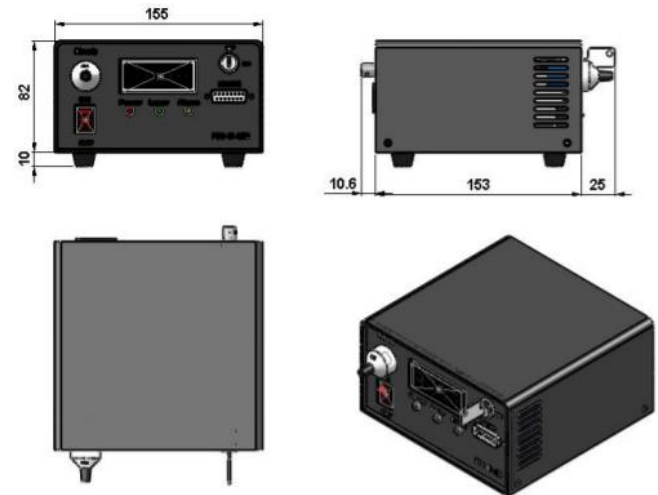

A Version Laboratory Power Supply (Y=T)



Note: The above specifications are subject to change without notice.