



155Mbps TX:1550nm/RX:1310nm SMF 60km BiDi SFP LC Optical Transceiver

Model No. CS5T3-03H-3U-Tx-L

FEATURES

- Compliant with SONET/SDH standard
- Compliant with Fast Ethernet standard
- Industry standard small form pluggable (SFP) package
- Simplex LC connector
- Single power supply 3.3V
- Differential LVPECL inputs and outputs
- TTL signal detect indicator
- Hot pluggable
- Class 1 laser product compliant with EN 60825-1
- LD Type: 1550 DFB
- Distance: 60km



DIAGNOSTICS

PARAMETER	RANGE	ACCURACY	UNIT	CALIBRATION
Temperature	-40 to 95	±3	°C	External
Voltage	3.0 to 3.6	±0.1	V	
Bias Current	0 to 100	±5	mA	
TX Power	-8 to +3	±3 dB	dBm	
RX Power	-31 to -8	±3 dB	dBm	

ABSOLUTE MAXIMUM RATINGS

PARAMETER	SYMBOL	MIN	MAX	UNIT	NOTES
Storage Temperature	T _S	-40	85	°C	
Supply Voltage	V _{CC}	-0.5	4.0	V	
Input Voltage	V _{IN}	-0.5	V _{CC}	V	
Output Current	I _o	-	50	mA	
Operating Current	I _{OP}	-	400	mA	

RECOMMENDED OPERATING CONDITIONS

PARAMETER	SYMBOL	MIN	MAX	UNIT	NOTES
Case Operating Temperature	T _C	0	70	°C	CS5T3-03H-3U-TC-L
		-40	85		CS5T3-03H-3U-TI-L
Supply Voltage	V _{CC}	3.1	3.5	V	
Supply Current	I _{TX} + I _{RX}	-	300	mA	

Lasermate Group, Inc.

19608 Camino De Rosa, Walnut, CA 91789, USA

Tel: (909)718-0999 | Fax: (909)718-0998 | E-mail: info@lasermate.com | URL: <http://www.lasermate.com>



TRANSMITTER ELECTRO-OPTICAL CHARACTERISTICS ($V_{CC} = 3.1V$ to $3.5V$, $T_C = 0^\circ C$ to $70^\circ C$, $-40^\circ C$ to $85^\circ C$)

PARAMETER	SYMBOL	MIN	TYP.	MAX	UNIT	NOTES
Output Optical Power 9/125um fiber	P_{out}	-5	-	0	dBm	Average
Extinction Ratio	ER	9	-	-	dB	
Center Wavelength	λ_c	1520	1550	1580	nm	
Spectral Width (-20dB)	$\Delta\lambda$	-	-	1.0	nm	
Side Mode Suppression Ratio	SMSR	30	-	-	dB	
Rise/Fall Time, 10%~90%	$T_{r,f}$	-	1	2	ns	
Output Eye	Compliant with Telcordia GR-253-CORE Issue 3 and ITU-T recommendation G-957					
Max. P_{out} TX-DISABLE Asserted	P_{OFF}	-	-	-45	dBm	
Differential Input Voltage	V_{DIFF}	0.4	-	2.0	V	
Transmit Fault Output-Low	TX_FAULT _L	0.0	-	0.5	V	
Transmit Fault Output-High	TX_FAULT _H	2.4	-	V_{CC}	V	
Time to initialize, include reset of TX_FAULT	t_init	-	-	300	ms	
TX_FAULT from fault to assertion	t_fault	-	-	100	us	
TX_DISABLE time to start reset	t_reset	10	-	-	us	

RECEIVER ELECTRO-OPTICAL CHARACTERISTICS ($V_{CC} = 3.1V$ to $3.5V$, $T_C = 0^\circ C$ to $70^\circ C$, $-40^\circ C$ to $85^\circ C$)

PARAMETER	SYMBOL	MIN	TYP.	MAX	UNIT	NOTES
Optical Input Power-Maximum	P_{IN}	0	-	-	dBm	BER< 10^{-10}
RX Sensitivity @OC-3	P_{IN}	-	-	-34	dBm	PRBS23, BER< 10^{-10}
RX Sensitivity @125Mbps	P_{IN}	-	-	-34	dBm	PRBS7, BER< 10^{-10}
Operating Center Wavelength	λ_c	1260	-	1360	nm	
Optical Return Loss	ORL	14	-	-	dB	$\lambda=1260\sim1360nm$
Optical Isolation	ISO	-	-	-45	dB	$\lambda=1480\sim1600nm$
Loss of Signal-Asserted	P_A	-	-	-34	dBm	
Loss of Signal-Deasserted	P_D	-45	-	-	dBm	
Differential Output Voltage	V_{DIFF}	0.5	-	1.2	V	
Receiver Loss of Signal Output Voltage-Low	RX_LOS _L	0	-	0.5	V	
Receiver Loss of Signal Output Voltage-High	RX_LOS _H	2.4	-	V_{CC}	V	



BLOCK DIAGRAM OF TRANSCEIVER

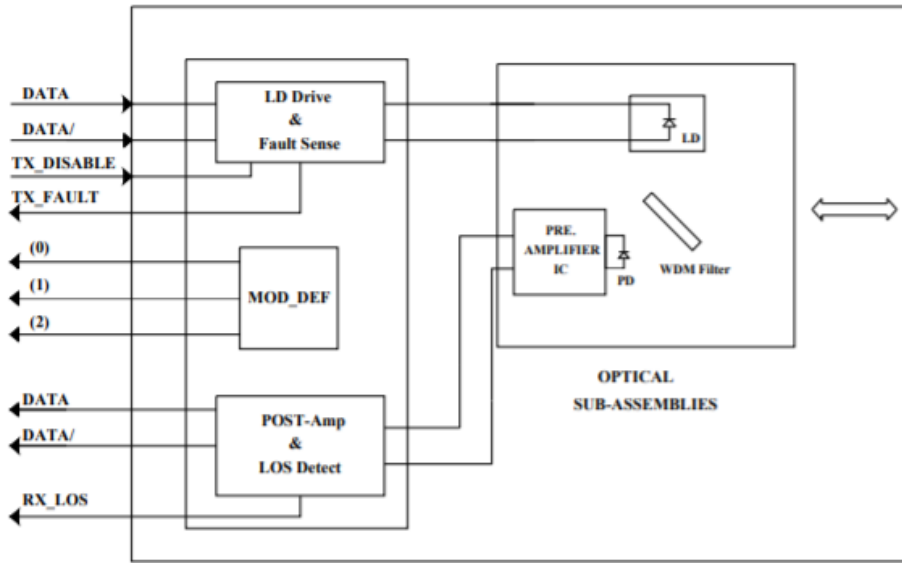

Transmitter and Receiver Optical Sub-assembly Section - A 1550 nm InGaAsP laser and an InGaAs PIN photodiode integrate with an WDM filter to form a bi-directional single fiber optical subassembly (OSA).

TX_FAULT - When sensing an improper power level in the laser driver, the SFP set this signal high and turns off the Laser. TX_FAULT can be reset with the TX_DISABLE line. The signal is in TTL level.

TX_DISABLE - The TX_DISABLE signal is high (TTL logic "1") to turn off the laser output.

Receive Loss (RX_LOS) - The RX_LOS is high (logic "1") when there is no incoming light from the companion transceiver. This signal is normally used by the system for the diagnostic purpose. The signal is operated in TTL level.

DIMENSIONS

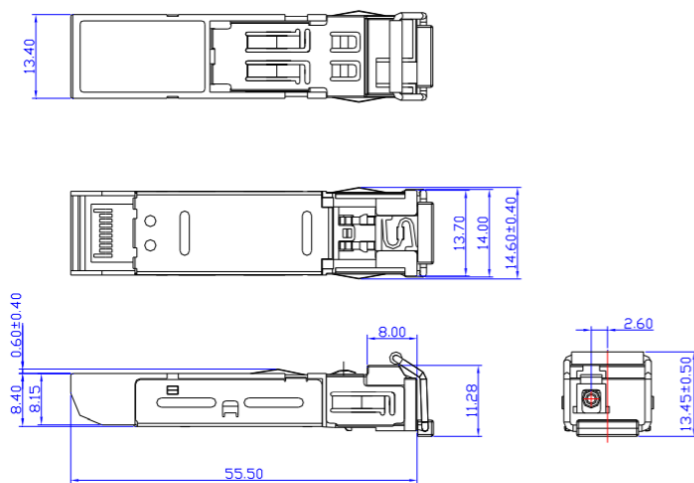

DIMENSIONS ARE IN MILLIMETERS

ALL DIMENSIONS ARE ± 0.2mm UNLESS OTHERWISE SPECIFIED

Lasermate Group, Inc.

19608 Camino De Rosa, Walnut, CA 91789, USA

Tel: (909)718-0999 | Fax: (909)718-0998 | E-mail: info@lasermate.com | URL: http://www.lasermate.com



SFP HOST BOARD MECHANICAL LAYOUT

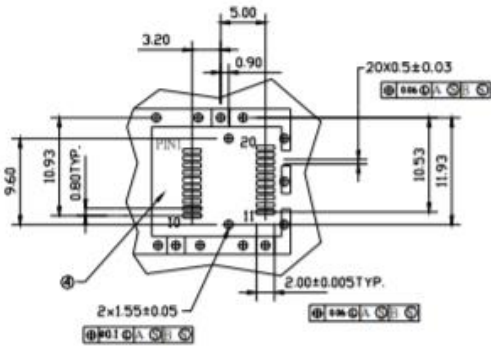
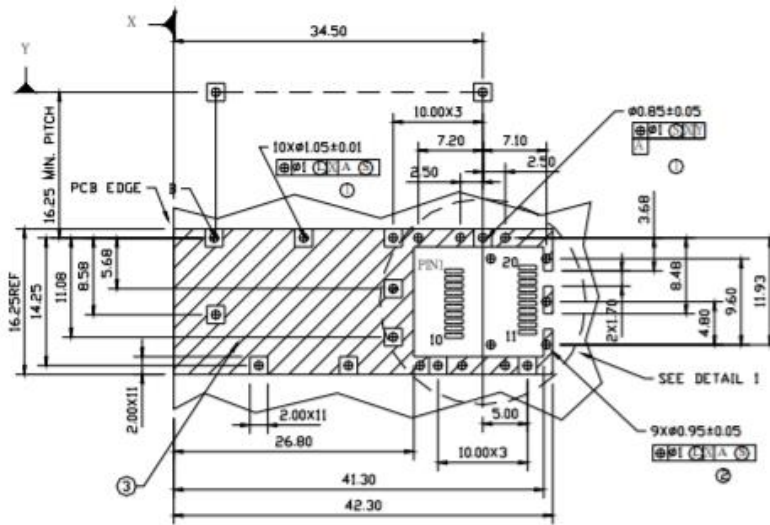

DETAIL I

LEGEND

- 1.PADS AND VIAS ARE CHASSIS GROUND
- 2.THROUGH HOLES, PLATING OPTIONAL
- 3.HATCHED AREA DENOTES COMPONENT AND TRACE KEEPOUT(EXCEPT CHASSIS GROUND)
- 4.AREA DENOTES COMPONENT KEEPOUT (TRACES ALLOWED)

DIMENSIONS ARE IN MILLIMETERS

ASSEMBLY DRAWING (unit: mm)

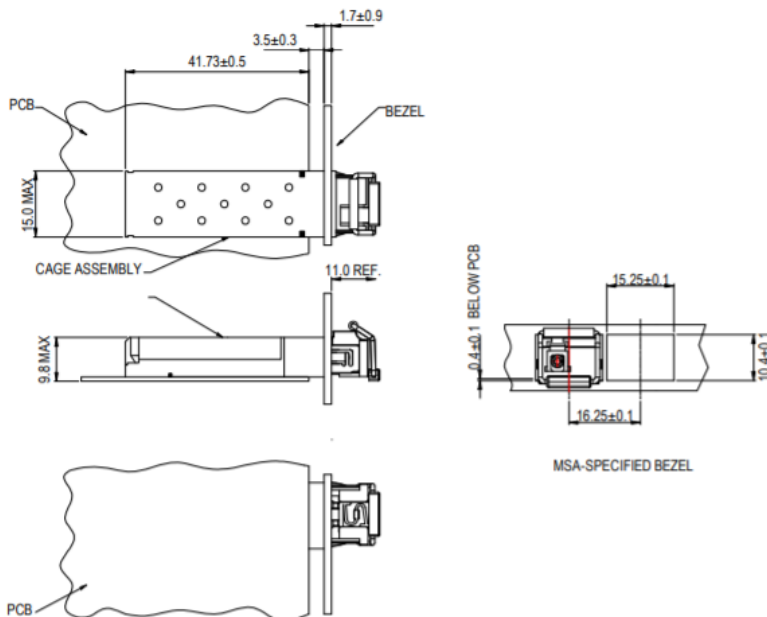

Lasermate Group, Inc.

19608 Camino De Rosa, Walnut, CA 91789, USA

Tel: (909)718-0999 | Fax: (909)718-0998 | E-mail: info@lasermate.com | URL: <http://www.lasermate.com>



PIN ASSIGNMENT

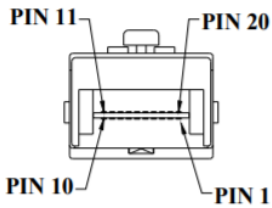

Pin	Signal Name	Description
1	T_{GND}	Transmit Ground
2	TX_FAULT	Transmit Fault
3	$TX_DISABLE$	Transmit Disable
4	$MOD_DEF (2)$	SDA Serial Data Signal
5	$MOD_DEF (1)$	SCL Serial Clock Signal
6	$MOD_DEF (0)$	TTL Low
7	$RATE_SELECT$	Open Circuit
8	RX_LOS	Receiver Loss of Signal, TTL High, open collector
9	R_{GND}	Receiver Ground
10	R_{GND}	Receiver Ground
11	R_{GND}	Receiver Ground
12	$RX-$	Receive Data Bar, Differential PECL, ac coupled
13	$RX+$	Receive Data, Differential PECL, ac coupled
14	R_{GND}	Receiver Ground
15	V_{CCR}	Receiver Power Supply
16	V_{CCT}	Transmitter Power Supply
17	T_{GND}	Transmitter Ground
18	$TX+$	Transmit Data, Differential PECL, ac coupled
19	$TX-$	Transmit Data Bar, Differential PECL, ac coupled
20	T_{GND}	Transmitter Ground

ORDERING INFORMATION

PART NUMBER	OPERATING TEMPERATURE
CS5T3-03H-3U-TC-L	0°C to 70°C
CS5T3-03H-3U-TI-L	-40°C to 85°C

Note: The specifications subject to change without notice.