



# 1.25Gbps TX:1310nm/RX:1550nm SMF 40km BiDi SFP SC Optical Transceiver

Model No. CS3T5-24H-3L-Tx-C

## FEATURES

- Compliant with IEEE802.3z Gigabit Ethernet Standard
- Compliant with Fiber Channel 100-SM-LC-L standard
- Multi rate 125Mbps, 1.06Gbps and 1.25Gbps
- Industry standard small form pluggable (SFP) package
- Simplex SC connector
- Single power supply 3.3V
- Differential LVPECL inputs and outputs
- TTL signal detect indicator
- Hot pluggable
- Class 1 laser product compliant with EN 60825-1
- LD Type: 1310 DFB
- Distance: 40km



## DIAGNOSTICS

PARAMETER	RANGE	ACCURACY	UNIT	CALIBRATION
Temperature	-40 to 95	±3	°C	External
Voltage	0 to V <sub>CC</sub>	±0.1	V	
Bias Current	0 to 120	±5	mA	
TX Power	-6 to +5	±3 dB	dBm	
RX Power	-21 to -3	±3 dB	dBm	

## ABSOLUTE MAXIMUM RATINGS

PARAMETER	SYMBOL	MIN	MAX	UNIT	NOTES
Storage Temperature	T <sub>S</sub>	-40	85	°C	
Supply Voltage	V <sub>CC</sub>	-0.5	4.0	V	
Input Voltage	V <sub>IN</sub>	-0.5	V <sub>CC</sub>	V	

## RECOMMENDED OPERATING CONDITIONS

PARAMETER	SYMBOL	MIN	MAX	UNIT	NOTES
Case Operating Temperature	T <sub>C</sub>	0	70	°C	CS3T5-24H-3L-TC-C
		-40	85		CS3T5-24H-3L-TI-C
Supply Voltage	V <sub>CC</sub>	3.1	3.5	V	
Supply Current	I <sub>TX</sub> + I <sub>RX</sub>		300	mA	

**TRANSMITTER ELECTRO-OPTICAL CHARACTERISTICS ( $V_{CC} = 3.1V$  to  $3.5V$ ,  $T_C = 0^{\circ}C$  to  $70^{\circ}C$ ,  $-40^{\circ}C$  to  $85^{\circ}C$ )**

PARAMETER	SYMBOL	MIN	TYP.	MAX	UNIT	NOTES
Output Optical Power 9/125um fiber	$P_{out}$	-3	-	+2	dBm	Average
Extinction Ratio	ER	9	-	-	dB	
Center Wavelength	$\lambda_c$	1280	1310	1340	nm	
Spectral Width (-20dB)	$\Delta\lambda$	-	-	1	nm	
Side Mode Suppression Ratio	SMSR	30			dB	
Rise/Fall Time (20%~80%)	$T_{r,f}$	-	-	260	ps	
Relative Intensity Noise	RIN	-	-	-120	dB/Hz	
Total Jitter	TJ	-	-	227	ps	
Output Eye	Compliant with IEEE802.3z					
Max. $P_{out}$ TX-DISABLE Asserted	$P_{OFF}$	-	-	-45	dBm	
Differential Input Voltage	$V_{DIFF}$	0.4	-	2.0	V	
Transmit Fault Output-Low	TX_FAULT <sub>L</sub>	0.0	-	0.5	V	
Transmit Fault Output-High	TX_FAULT <sub>H</sub>	2.4	-	$V_{CC}$	V	
Time to initialize, include reset of TX_FAULT	$t_{init}$	-	-	300	ms	
TX_FAULT from fault to assertion	$t_{fault}$	-	-	100	us	
TX_DISABLE time to start reset	$t_{reset}$	10	-	-	us	

**RECEIVER ELECTRO-OPTICAL CHARACTERISTICS ( $V_{CC} = 3.1V$  to  $3.5V$ ,  $T_C = 0^{\circ}C$  to  $70^{\circ}C$ ,  $-40^{\circ}C$  to  $85^{\circ}C$ )**

PARAMETER	SYMBOL	MIN	TYP.	MAX	UNIT	NOTES
Optical Input Power-Maximum	$P_{IN}$	0	-	-	dBm	BER< $10^{-12}$
RX Sensitivity @GbE	$P_{IN}$	-	-	-23	dBm	PRBS7, BER< $10^{-12}$
RX Sensitivity @1x FC	$P_{IN}$	-	-	-23	dBm	PRBS7, BER< $10^{-12}$
RX Sensitivity @125Mbps	$P_{IN}$	-	-	-23	dBm	PRBS7, BER< $10^{-10}$
Operating Center Wavelength	$\lambda_c$	1480	-	1580	nm	
Optical Return Loss	ORL	14	-	-	dB	$\lambda=1480\sim1580nm$
Optical Isolation	ISO	-	-	-45	dB	$\lambda=1260\sim1360nm$
Signal Detect-Asserted	$P_A$	-	-	-23	dBm	
Signal Detect-Deasserted	$P_D$	-35	-	-	dBm	
Differential Output Voltage	$V_{DIFF}$	0.5	-	1.2	V	
Data Output Rise, Fall Time (20%~80%)	$T_{r,f}$	-	-	0.35	ns	
Receiver Loss of Signal Output Voltage-Low	RX_LOS <sub>L</sub>	0	-	0.5	V	
Receiver Loss of Signal Output Voltage-High	RX_LOS <sub>H</sub>	2.4	-	$V_{CC}$	V	



**BLOCK DIAGRAM OF TRANSCEIVER**

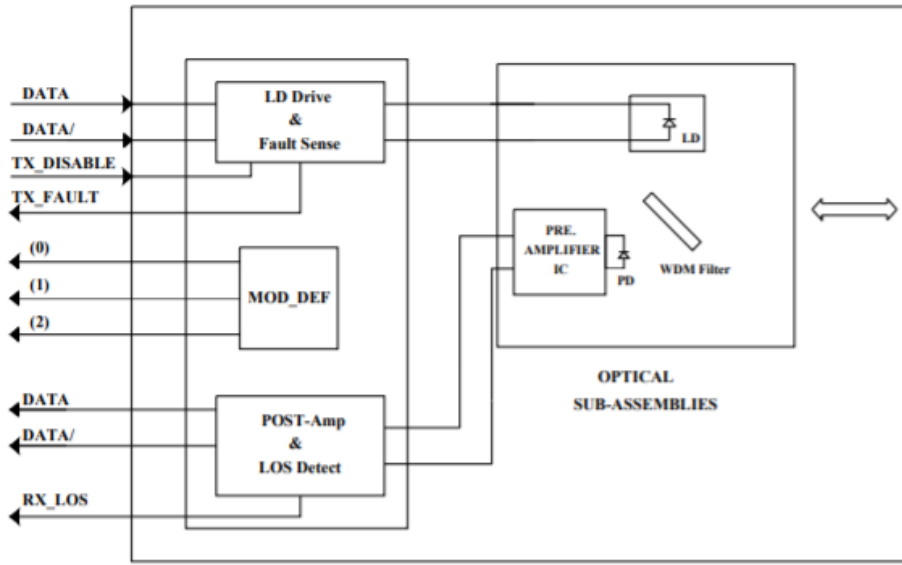

**Transmitter and Receiver Optical Sub-assembly Section** - A 1310 nm InGaAsP laser and an InGaAs PIN photodiode integrate with an WDM filter to form a bi-directional single fiber optical subassembly (OSA). The laser of OSA is driven by a LD driver IC which converts differential input LVPECL logic signals into an analog laser driving current. The photodiode of OSA is connected to a circuit providing post-amplification quantization, and optical signal detection.

**TX\_FAULT** - When sensing an improper power level in the laser driver, the SFP set this signal high and turns off the Laser. TX\_FAULT can be reset with the TX\_DISABLE line. The signal is in TTL level.

**TX\_DISABLE** - The TX\_DISABLE signal is high (TTL logic "1") to turn off the laser output.

**Receive Loss (RX\_LOS)** - The RX\_LOS is high (logic "1") when there is no incoming light from the companion transceiver. This signal is normally used by the system for the diagnostic purpose. The signal is operated in TTL level.

**DIMENSIONS**

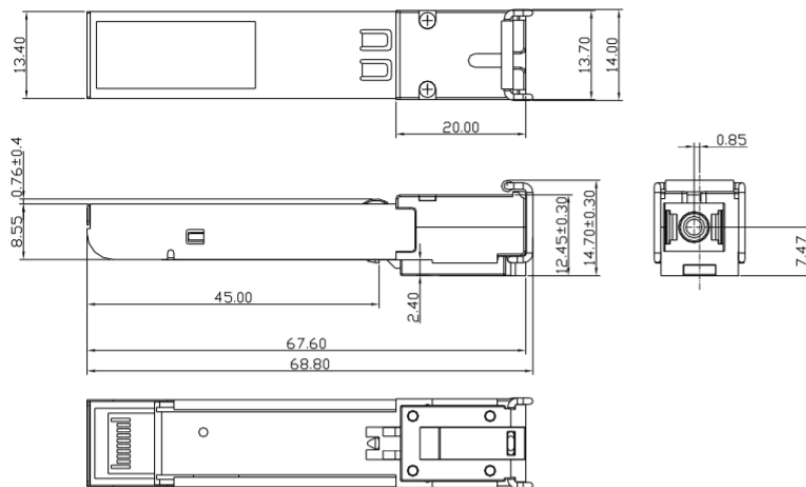

**DIMENSIONS ARE IN MILLIMETERS**

**ALL DIMENSIONS ARE ±0.2mm UNLESS OTHERWISE SPECIFIED**

**Lasermate Group, Inc.**

19608 Camino De Rosa, Walnut, CA 91789, USA

Tel: (909)718-0999 | Fax: (909)718-0998 | E-mail: info@lasermate.com | URL: <http://www.lasermate.com>





## PIN ASSIGNMENT

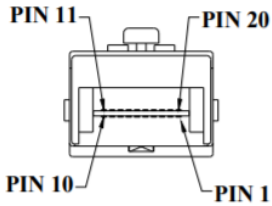

Pin	Signal Name	Description
1	$T_{GND}$	Transmit Ground
2	$TX\_FAULT$	Transmit Fault
3	$TX\_DISABLE$	Transmit Disable
4	$MOD\_DEF (2)$	SDA Serial Data Signal
5	$MOD\_DEF (1)$	SCL Serial Clock Signal
6	$MOD\_DEF (0)$	TTL Low
7	$RATE\_SELECT$	Open Circuit
8	$RX\_LOS$	Receiver Loss of Signal, TTL High, open collector
9	$R_{GND}$	Receiver Ground
10	$R_{GND}$	Receiver Ground
11	$R_{GND}$	Receiver Ground
12	$RX-$	Receive Data Bar, Differential PECL, ac coupled
13	$RX+$	Receive Data, Differential PECL, ac coupled
14	$R_{GND}$	Receiver Ground
15	$V_{CCR}$	Receiver Power Supply
16	$V_{CCT}$	Transmitter Power Supply
17	$T_{GND}$	Transmitter Ground
18	$TX+$	Transmit Data, Differential PECL, ac coupled
19	$TX-$	Transmit Data Bar, Differential PECL, ac coupled
20	$T_{GND}$	Transmitter Ground

## EYE SAFETY MARK

The single-mode transceiver is a class 1 laser product. It complies with EN 60825-1 and FDA 21 CFR 1040.10 and 1040.11. In order to meet laser safety requirements, the transceiver shall be operated within the Absolute Maximum Ratings.

## Required Mark

**Class 1 Laser Product  
Complies with  
21 CFR 1040.10 and 1040.11**

**[Caution]** All adjustments have been done at the factory before the shipment of the devices. No maintenance and user serviceable part is required. Tampering with and modifying the performance of the device will result in voided product warranty.

**Lasermate Group, Inc.**

19608 Camino De Rosa, Walnut, CA 91789, USA

Tel: (909)718-0999 | Fax: (909)718-0998 | E-mail: [info@lasermate.com](mailto:info@lasermate.com) | URL: <http://www.lasermate.com>



**Lasermate Group, Inc.**

*The Friend of Lasers*



**ORDERING INFORMATION**

<b>PART NUMBER</b>	<b>OPERATING TEMPERATURE</b>
CS3T5-24H-3L-TC-C	0°C to 70°C
CS3T5-24H-3L-TI-C	-40°C to 85°C

**Note:** The specifications subject to change without notice.

**Lasermate Group, Inc.**

19608 Camino De Rosa, Walnut, CA 91789, USA

Tel: (909)718-0999 | Fax: (909)718-0998 | E-mail: [info@lasermate.com](mailto:info@lasermate.com) | URL: <http://www.lasermate.com>