



1.25Gbps TX:1310nm/RX:1490nm SMF 60km BiDi SFP LC Optical Transceiver

Model No. CS3T4-24H-3U-Tx-L

FEATURES

- RoHS Compliant
- Compliant with IEEE802.3ah 1000BASE-BX application
- Compliant with SFF8472 Digital Diagnostic Standard
- Industry standard small form pluggable (SFP) package
- Hot pluggable
- Class 1 laser product compliant with EN 60825-1
- LD Type: 1310 DFB
- Distance: 60km



DIAGNOSTICS

PARAMETER	RANGE	ACCURACY	UNIT	CALIBRATION
Temperature	-40 to 95	±3	°C	External
Voltage	3.0 to 3.6	±0.1	V	
Bias Current	0 to 100	±10%	mA	
TX Power	-3 to +7	±3 dB	dBm	
RX Power	-23 to -3	±3 dB	dBm	

ABSOLUTE MAXIMUM RATINGS

PARAMETER	SYMBOL	MIN	MAX	UNIT	NOTES
Storage Temperature	T _S	-40	85	°C	
Supply Voltage	V _{CC}	-0.5	4.0	V	
Input Voltage	V _{IN}	-0.5	V _{CC}	V	

RECOMMENDED OPERATING CONDITIONS

PARAMETER	SYMBOL	MIN	MAX	UNIT	NOTES
Case Operating Temperature	T _C	0	70	°C	CS3T4-24H-3U-TC-L
		-40	85		CS3T4-24H-3U-TI-L
Supply Voltage	V _{CC}	3.1	3.5	V	
Supply Current	I _{TX} + I _{RX}	-	300	mA	
Relative Humidity (Non-condensing)	RH	5	95	%	

Lasermate Group, Inc.

19608 Camino De Rosa, Walnut, CA 91789, USA

Tel: (909)718-0999 | Fax: (909)718-0998 | E-mail: info@lasermate.com | URL: <http://www.lasermate.com>

**TRANSMITTER ELECTRO-OPTICAL CHARACTERISTICS ($V_{CC} = 3.1V$ to $3.5V$, $T_C = 0^\circ C$ to $70^\circ C$, $-40^\circ C$ to $85^\circ C$)**

PARAMETER	SYMBOL	MIN	TYP.	MAX	UNIT	NOTES
Output Optical Power 9/125um fiber	P_{out}	0	-	+5	dBm	Average
Extinction Ratio	ER	7	-	-	dB	
Center Wavelength	λ_c	1290	1310	1330	nm	
Spectral Width (-20dB)	$\Delta\lambda$	-	-	1	nm	
Side Mode Suppression Ratio	SMSR	30			dB	
Rise/Fall Time (20%~80%)	$T_{r,f}$	-	-	260	ps	
Relative Intensity Noise	RIN	-	-	-120	dB/Hz	
Total Jitter	TJ	-	-	227	ps	
Output Eye	Compliant with IEEE802.3z					
Max. P_{out} TX-DISABLE Asserted	P_{OFF}	-	-	-45	dBm	
Differential Input Voltage	V_{DIFF}	0.4	-	2.0	V	
Transmit Fault Output-Low	TX_FAULT _L	0.0	-	0.5	V	
Transmit Fault Output-High	TX_FAULT _H	2.4	-	V_{CC}	V	
Time to initialize, include reset of TX_FAULT	t_{init}	-	-	300	ms	
TX_FAULT from fault to assertion	t_{fault}	-	-	100	us	
TX_DISABLE time to start reset	t_{reset}	10	-	-	us	

RECEIVER ELECTRO-OPTICAL CHARACTERISTICS ($V_{CC} = 3.1V$ to $3.5V$, $T_C = 0^\circ C$ to $70^\circ C$, $-40^\circ C$ to $85^\circ C$)

PARAMETER	SYMBOL	MIN	TYP.	MAX	UNIT	NOTES
Optical Input Power-Maximum	P_{IN}	0	-	-	dBm	PRBS7, BER<10 ⁻¹²
RX Sensitivity	P_{IN}	-	-	-24	dBm	PRBS7, BER<10 ⁻¹²
Operating Center Wavelength	λ_c	1480	-	1500	nm	
Optical Return Loss	ORL	14	-	-	dB	$\lambda=1480\sim1500nm$
Optical Isolation	ISO	-	-	-45	dB	$\lambda=1260\sim1360nm$
LOS Asserted	P_A	-35	-	-	dBm	
LOS Deasserted	P_D	-	-	-24	dBm	
Differential Output Voltage	V_{DIFF}	0.5	-	1.2	V	
Data Output Rise, Fall Time (20%~80%)	$T_{r,f}$	-	-	0.35	ns	
Receiver Loss of Signal Output Voltage-Low	RX_LOS _L	0	-	0.5	V	
Receiver Loss of Signal Output Voltage-High	RX_LOS _H	2.4	-	V_{CC}	V	



DIMENSIONS

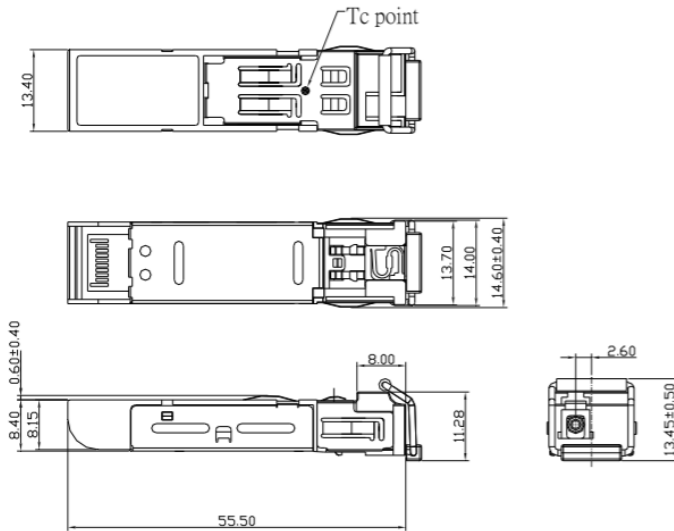

DIMENSIONS ARE IN MILLIMETERS

ALL DIMENSIONS ARE ± 0.2mm UNLESS OTHERWISE SPECIFIED

SFP HOST BOARD MECHANICAL LAYOUT

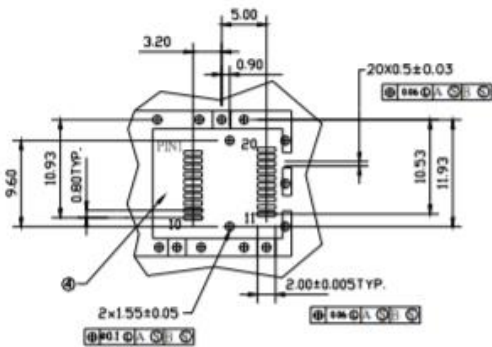
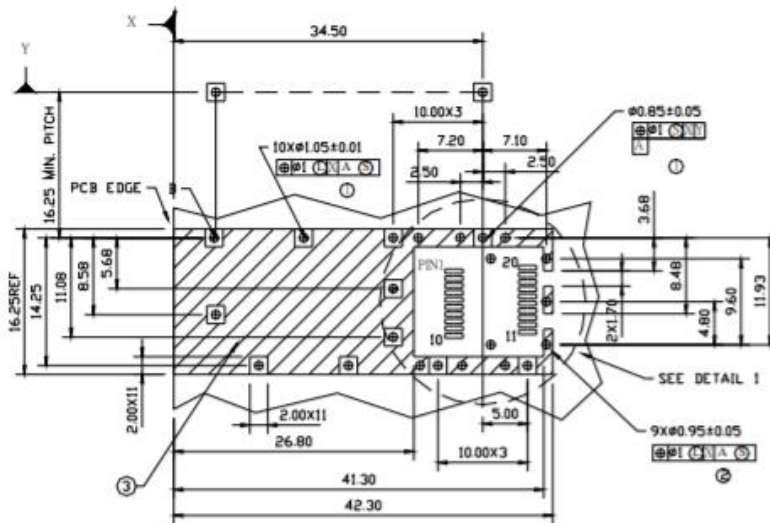

DETAIL I

LEGEND

1. PADS AND VIAS ARE CHASSIS GROUND
2. THROUGH HOLES, PLATING OPTIONAL
3. HATCHED AREA DENOTES COMPONENT AND TRACE KEEPOUT (EXCEPT CHASSIS GROUND)
4. AREA DENOTES COMPONENT KEEPOUT (TRACES ALLOWED)

DIMENSIONS ARE IN MILLIMETERS

Lasermate Group, Inc.

19608 Camino De Rosa, Walnut, CA 91789, USA

Tel: (909)718-0999 | Fax: (909)718-0998 | E-mail: info@lasermate.com | URL: <http://www.lasermate.com>



ASSEMBLY DRAWING (unit: mm)

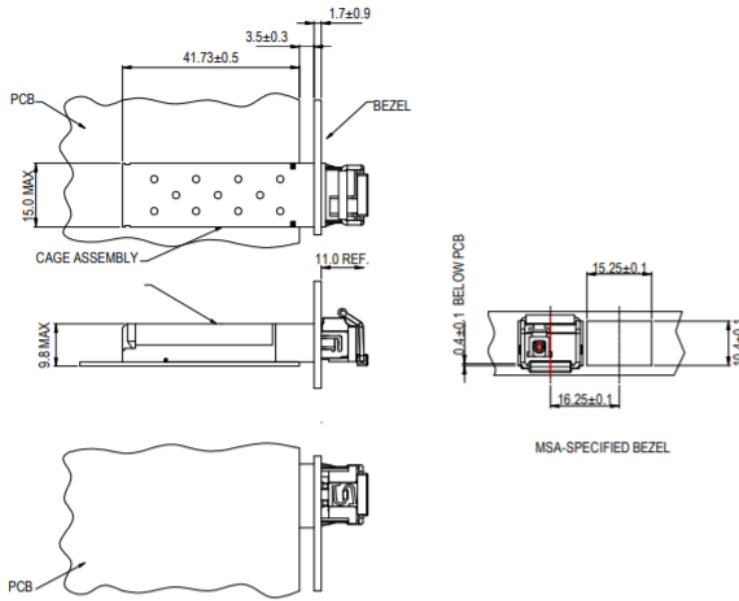

PIN ASSIGNMENT

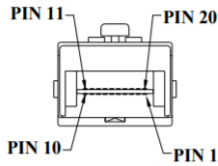

Pin	Signal Name	Description
1	T_{GND}	Transmit Ground
2	TX_FAULT	Transmit Fault
3	$TX_DISABLE$	Transmit Disable
4	$MOD_DEF (2)$	SDA Serial Data Signal
5	$MOD_DEF (1)$	SCL Serial Clock Signal
6	$MOD_DEF (0)$	TTL Low
7	$RATE_SELECT$	Open Circuit
8	RX_LOS	Receiver Loss of Signal, TTL High, open collector
9	R_{GND}	Receiver Ground
10	R_{GND}	Receiver Ground
11	R_{GND}	Receiver Ground
12	$RX-$	Receive Data Bar, Differential , ac coupled
13	$RX+$	Receive Data, Differential , ac coupled
14	R_{GND}	Receiver Ground
15	V_{CCR}	Receiver Power Supply
16	V_{CCT}	Transmitter Power Supply
17	T_{GND}	Transmitter Ground
18	$TX+$	Transmit Data, Differential , ac coupled
19	$TX-$	Transmit Data Bar, Differential , ac coupled
20	T_{GND}	Transmitter Ground

Lasermate Group, Inc.

19608 Camino De Rosa, Walnut, CA 91789, USA

Tel: (909)718-0999 | Fax: (909)718-0998 | E-mail: info@lasermate.com | URL: <http://www.lasermate.com>



ORDERING INFORMATION

PART NUMBER	OPERATING TEMPERATURE
CS3T4-24H-3U-TC-L	0°C to 70°C
CS3T4-24H-3U-TI-L	-40°C to 85°C

Note: The specifications subject to change without notice.