



1.25Gbps TX:1310nm/RX:1490nm SMF 20km BiDi SFP LC Optical Transceiver

Model No. CS3T4-24H-3M-Tx-L

FEATURES

- RoHS Compliant
- Compliant with IEEE802.3ah 1000BASE-BX application
- Compliant with SFF8472 Digital Diagnostic Standard
- Industry standard small form pluggable (SFP) package
- Hot pluggable
- Class 1 laser product compliant with EN 60825-1
- LD Type: 1310 FP
- Distance: 20km



DIAGNOSTICS

PARAMETER	RANGE	ACCURACY	UNIT	CALIBRATION
Temperature	-40 to 95	±3	°C	External
Voltage	3.0 to 3.6	±0.1	V	
Bias Current	0 to 100	±10%	mA	
TX Power	-11 to 0	±3 dB	dBm	
RX Power	-23 to -3	±3 dB	dBm	

ABSOLUTE MAXIMUM RATINGS

PARAMETER	SYMBOL	MIN	MAX	UNIT	NOTES
Storage Temperature	T _S	-40	85	°C	
Supply Voltage	V _{CC}	-0.5	4.0	V	
Input Voltage	V _{IN}	-0.5	V _{CC}	V	

RECOMMENDED OPERATING CONDITIONS

PARAMETER	SYMBOL	MIN	MAX	UNIT	NOTES
Case Operating Temperature	T _C	0	70	°C	CS3T4-24H-3M-TC-L
		-40	85		CS3T4-24H-3M-TI-L
Supply Voltage	V _{CC}	3.1	3.5	V	
Supply Current	I _{TX} + I _{RX}	-	300	mA	
Relative Humidity (Non-condensing)	RH	5	95	%	

**TRANSMITTER ELECTRO-OPTICAL CHARACTERISTICS ($V_{CC} = 3.1V$ to $3.5V$, $T_C = 0^{\circ}C$ to $70^{\circ}C$, $-40^{\circ}C$ to $85^{\circ}C$)**

PARAMETER	SYMBOL	MIN	TYP.	MAX	UNIT	NOTES
Output Optical Power 9/125um fiber	P_{out}	-8	-	-3	dBm	Average
Extinction Ratio	ER	9	-	-	dB	
Center Wavelength	λ_C	1260	1310	1360	nm	
Spectral Width (RMS)	$\Delta\lambda$	-	-	2.5	nm	
Rise/Fall Time (20%~80%)	$T_{r,f}$	-	-	260	ps	
Relative Intensity Noise	RIN	-	-	-120	dB/Hz	
Total Jitter	TJ	-	-	227	ps	
Output Eye	Compliant with IEEE802.3z					
Max. P_{out} TX-DISABLE Asserted	P_{OFF}	-	-	-45	dBm	
Differential Input Voltage	V_{DIFF}	0.4	-	2.0	V	
Transmit Fault Output-Low	TX_FAULT _L	0.0	-	0.5	V	
Transmit Fault Output-High	TX_FAULT _H	2.4	-	V_{CC}	V	
Time to initialize, include reset of TX_FAULT	t_{init}	-	-	300	ms	
TX_FAULT from fault to assertion	t_{fault}	-	-	100	us	
TX_DISABLE time to start reset	t_{reset}	10	-	-	us	

RECEIVER ELECTRO-OPTICAL CHARACTERISTICS ($V_{CC} = 3.1V$ to $3.5V$, $T_C = 0^{\circ}C$ to $70^{\circ}C$, $-40^{\circ}C$ to $85^{\circ}C$)

PARAMETER	SYMBOL	MIN	TYP.	MAX	UNIT	NOTES
Optical Input Power-Maximum	P_{IN}	-2	-	-	dBm	PRBS7, BER<10 ⁻¹²
RX Sensitivity	P_{IN}	-	-	-23	dBm	PRBS7, BER<10 ⁻¹²
Operating Center Wavelength	λ_C	1480	-	1500	nm	
Optical Return Loss	ORL	14	-	-	dB	$\lambda=1480\sim1500nm$
Optical Isolation	ISO	-	-	-45	dB	$\lambda=1260\sim1360nm$
LOS Asserted	P_A	-35	-	-	dBm	
LOS Deasserted	P_D	-	-	-23	dBm	
Differential Output Voltage	V_{DIFF}	0.5	-	1.2	V	
Data Output Rise, Fall Time (20%~80%)	$T_{r,f}$	-	-	0.35	ns	
Receiver Loss of Signal Output Voltage-Low	RX_LOS _L	0	-	0.5	V	
Receiver Loss of Signal Output Voltage-High	RX_LOS _H	2.4	-	V_{CC}	V	



DIMENSIONS

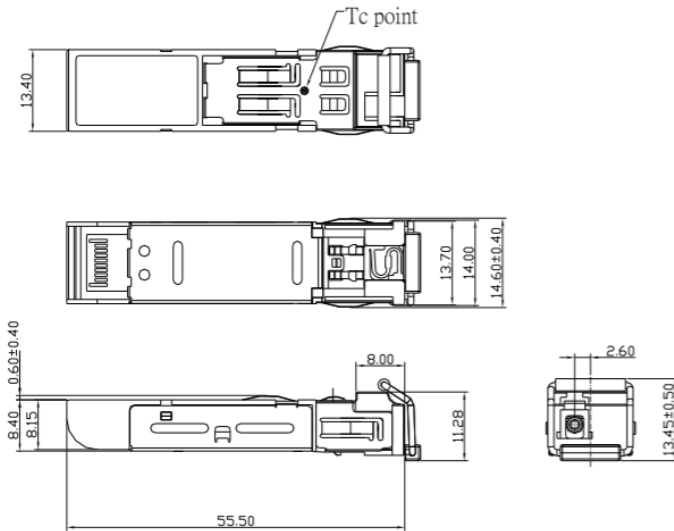

DIMENSIONS ARE IN MILLIMETERS

ALL DIMENSIONS ARE ± 0.2mm UNLESS OTHERWISE SPECIFIED

SFP HOST BOARD MECHANICAL LAYOUT

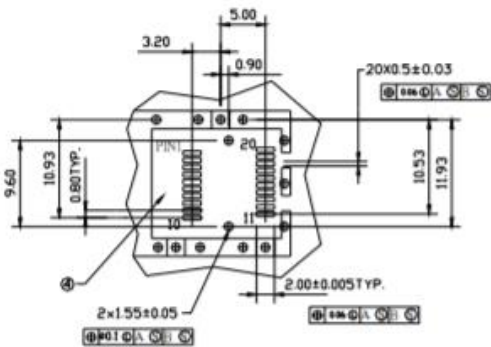
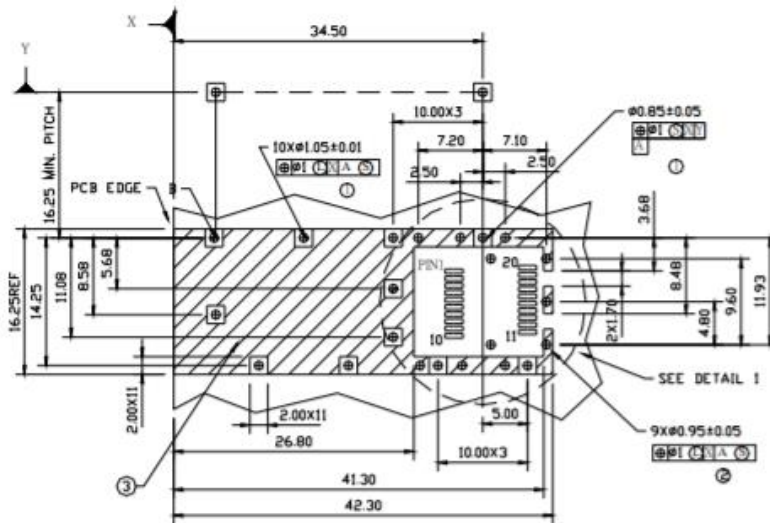

DETAIL I

LEGEND

- 1.PADS AND VIAS ARE CHASSIS GROUND
- 2.THROUGH HOLES, PLATING OPTIONAL
- 3.HATCHED AREA DENOTES COMPONENT AND TRACE KEEPOUT(EXCEPT CHASSIS GROUND)
- 4.AREA DENOTES COMPONENT KEEPOUT (TRACES ALLOWED)

DIMENSIONS ARE IN MILLIMETERS

Lasermate Group, Inc.

19608 Camino De Rosa, Walnut, CA 91789, USA

Tel: (909)718-0999 | Fax: (909)718-0998 | E-mail: info@lasermate.com | URL: <http://www.lasermate.com>



ASSEMBLY DRAWING (unit: mm)

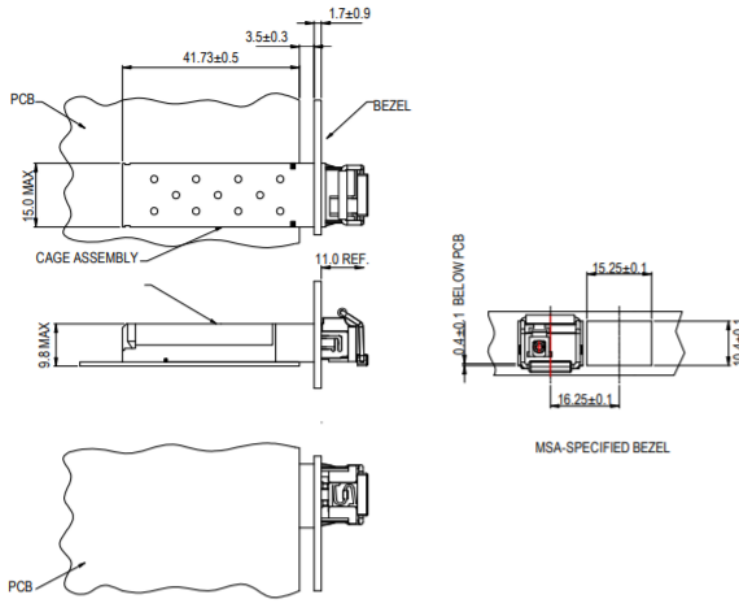

PIN ASSIGNMENT

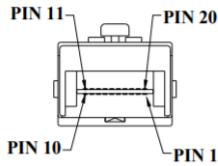

Pin	Signal Name	Description
1	T_{GND}	Transmit Ground
2	TX_FAULT	Transmit Fault
3	$TX_DISABLE$	Transmit Disable
4	$MOD_DEF (2)$	SDA Serial Data Signal
5	$MOD_DEF (1)$	SCL Serial Clock Signal
6	$MOD_DEF (0)$	TTL Low
7	$RATE_SELECT$	Open Circuit
8	RX_LOS	Receiver Loss of Signal, TTL High, open collector
9	R_{GND}	Receiver Ground
10	R_{GND}	Receiver Ground
11	R_{GND}	Receiver Ground
12	$RX-$	Receive Data Bar, Differential , ac coupled
13	$RX+$	Receive Data, Differential , ac coupled
14	R_{GND}	Receiver Ground
15	V_{CCR}	Receiver Power Supply
16	V_{CCT}	Transmitter Power Supply
17	T_{GND}	Transmitter Ground
18	$TX+$	Transmit Data, Differential , ac coupled
19	$TX-$	Transmit Data Bar, Differential , ac coupled
20	T_{GND}	Transmitter Ground

Lasermate Group, Inc.

19608 Camino De Rosa, Walnut, CA 91789, USA

Tel: (909)718-0999 | Fax: (909)718-0998 | E-mail: info@lasermate.com | URL: <http://www.lasermate.com>



ORDERING INFORMATION

PART NUMBER	OPERATING TEMPERATURE
CS3T4-24H-3M-TC-L	0°C to 70°C
CS3T4-24H-3M-TI-L	-40°C to 85°C

Note: The specifications subject to change without notice.