



25Gbps TX:1330nm/RX:1270nm SMF 10km BiDi SFP28 LC Optical Transceiver

Model No. CS3T2-25GF-3S-Tx-L

FEATURES

- Compliant with SFP+ MSA SFF-8431
- Compliant with SFF8472 diagnostic monitoring interface
- Simplex LC connector
- Hot pluggable
- Single power supply 3.3V
- Link distance up to 10km over single mode fiber
- LD Type: 1310nm DFB



DIAGNOSTICS

PARAMETER	RANGE	ACCURACY	UNIT	CALIBRATION
Internal Transceiver Temperature	-20 to 85	±3	°C	Internal
Internal Transceiver Voltage	3.1 to 3.5	±0.1	V	
Bias Current	0 to 15	±10%	mA	
TX Power	-4 to +2	±3	dBm	
RX Average Power	-13 to +0	±3	dBm	

ABSOLUTE MAXIMUM RATINGS

PARAMETER	SYMBOL	MIN	MAX	UNIT
Storage Temperature	T _S	-40	85	°C
Supply Voltage	V _{CC}	-0.5	4.0	V
Input Voltage	V _{IN}	-0.5	V _{CC}	V

RECOMMENDED OPERATING CONDITIONS

PARAMETER	SYMBOL	MIN	MAX	UNIT	NOTES
Case Operating Temperature	T _C	0	70	°C	CS3T2-25GF-3S-TC-L
		-20	85		CS3T2-25GF-3S-TM-L
Supply Voltage	V _{CC}	3.14	3.46	V	
Supply Current	I _{TX} + I _{RX}		300	mA	
Power Consumption	P	-	1.0	W	



TRANSMITTER ELECTRO-OPTICAL CHARACTERISTICS ($V_{CC} = 3.1V$ to $3.5V$, $T_C = 0^{\circ}C$ to $70^{\circ}C$, $-20^{\circ}C$ to $85^{\circ}C$)

PARAMETER	SYMBOL	MIN	TYP.	MAX	UNIT	NOTES
Data Rate	B	24	25.78	26.5	Gbps	
Output Optical Power	P_{out}	-4	-	+2	dBm	Average
Optical Modulation Amplitude	OMA	+1.2			dBm	
Extinction Ratio	ER	3.5			dB	
Center Wavelength	λ_c	1300	1310	1320	nm	
Spectral Width (RMS)	$\Delta\lambda$	-	-	1	nm	
Side Mode Suppression Ratio	SMSR	30			dB	
Max. P_{out} TX-DISABLE Asserted	P_{OFF}	-	-	-45	dBm	
Differential Input Voltage	V_{DIFF}	180		850	mV	
Transmit Fault Output-Low	TX_FAULT_L	0.0	-	0.5	V	
Transmit Fault Output-High	TX_FAULT_H	2.4	-	V_{CC}	V	
TX_DISABLE Assert Time	t_{off}	-	-	100	μs	
TX_DISABLE Negate Time	t_{on}	-	-	2	ms	
Time to Initialize, include reset of TX_FAULT	t_{init}	-	-	300	ms	
TX_FAULT from fault to assertion	t_{fault}	-	-	1	ms	
TX_DISABLE Time to start reset	t_{reset}	10	-	-	μs	

RECEIVER ELECTRO-OPTICAL CHARACTERISTICS ($V_{CC} = 3.1V$ to $3.5V$, $T_C = 0^{\circ}C$ to $70^{\circ}C$, $-20^{\circ}C$ to $85^{\circ}C$)

PARAMETER	SYMBOL	MIN	TYP.	MAX	UNIT	NOTES
Data Rate	B	24	25.78	26.5	Gbps	
Receiver Sensitivity	P_{IN}	-	-	-13	dBm	BER=5e-5
Stressed Receiver Sensitivity (OMA)	P_{IN}	-	-	-6.8	dBm	
Operating Center Wavelength	λ_c	1260	-	1280	nm	
Optical Return Loss	ORL	14	-	-	dB	
Loss of Signal-Asserted	P_A	-25	-	-	dBm	
Loss of Signal-Deasserted	P_D	-	-	-13	dBm	
Differential Output Voltage	V_{DIFF}	300	-	800	mV	
Receiver Loss of Signal Output Voltage-Low	RX_LOS_L	0	-	0.5	V	
Receiver Loss of Signal Output-High	RX_LOS_H	2.4	-	V_{CC}	V	
Receiver Loss of Signal Assert Time (off to on)	t_{A,RX_LOS}	-	-	100	μs	
Receiver Loss of Signal Assert Time (on to off)	t_{D,RX_LOS}	-	-	100	μs	

I2C ELECTRICAL CHARACTERISTICS

PARAMETER	SYMBOL	MIN	TYP.	MAX	UNIT	NOTES
High-Level Input Voltage SDA, SCL	V_{IH}	$0.7 * V_{CC}$	-	$V_{CC} + 0.3$	V	
Low-Level Input Voltage SDA, SCL	V_{IL}	-0.3	-	$0.3 * V_{CC}$	V	
SCL Clock Frequency	fSCL	0	-	400	kHz	
Serial Interface Clock Holdoff "Clock Stretching"	T_{clock_hold}	-	-	500	μs	



DIMENSIONS (unit: mm)

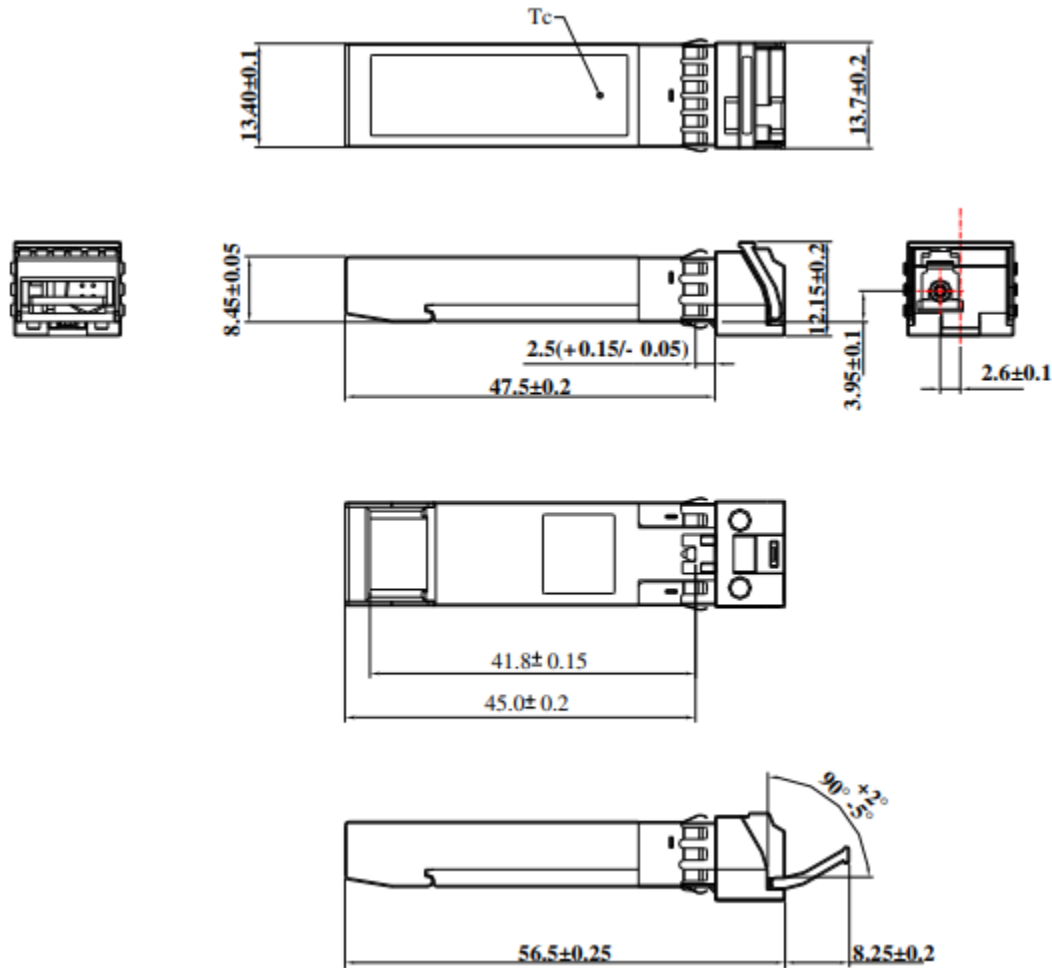



SFP HOST BOARD MECHANICAL LAYOUT

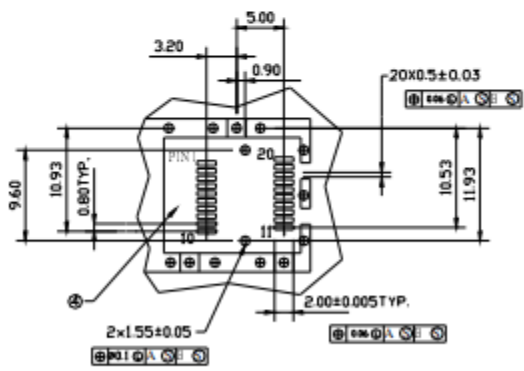
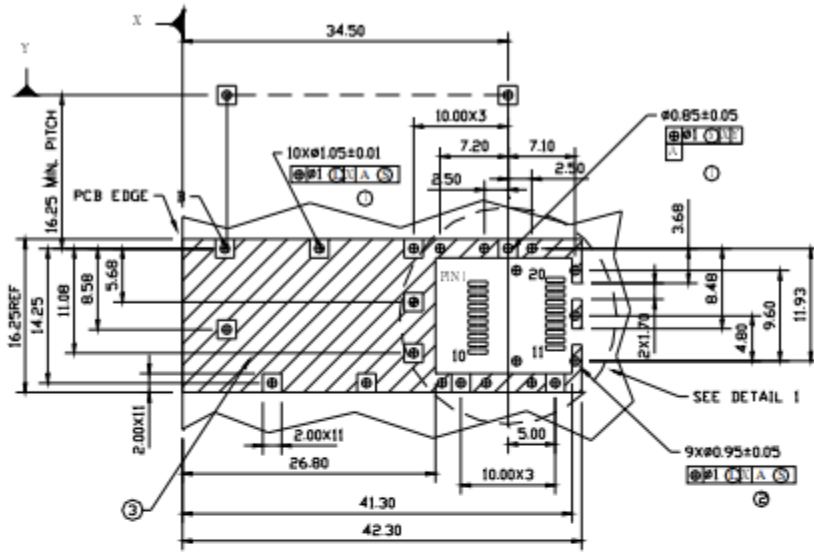

DETAIL 1

LEGEND

- 1.PADS AND VIAS ARE CHASSIS GROUND
- 2.THROUGH HOLES, PLATING OPTIONAL
- 3.HATCHED AREA DENOTES COMPONENT AND TRACE KEEPOUT(EXCEPT CHASSIS GROUND)
- 4.AREA DENOTES COMPONENT KEEPOUT (TRACES ALLOWED)

DIMENSIONS ARE IN MILLIMETERS

Unit: mm



ASSEMBLY DRAWING

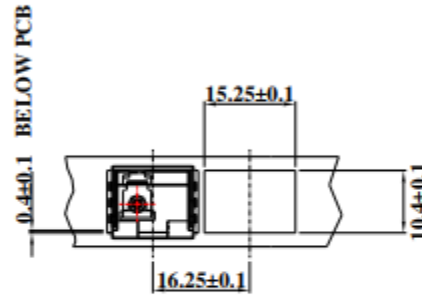
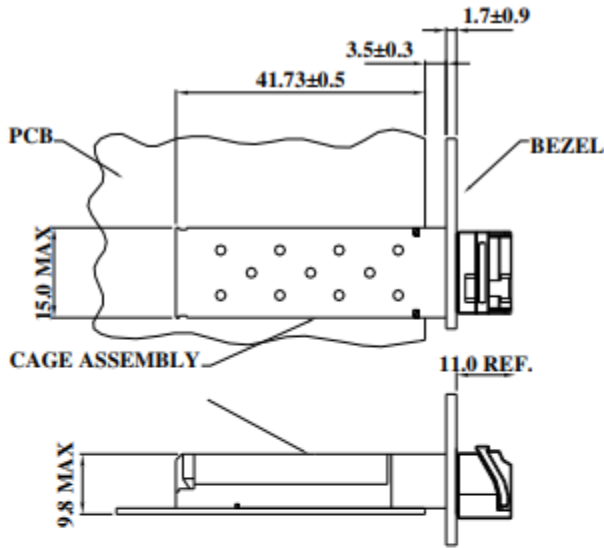

MSA-SPECIFIED BEZEL

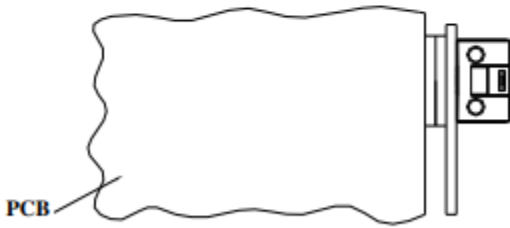

DIMENSIONS ARE IN MILLIMETERS

Unit: mm



PIN ASSIGNMENT

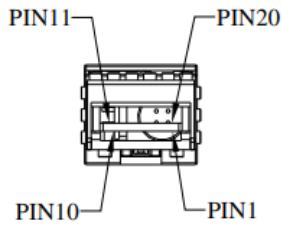

Pin	Signal Name	Description
1	T_{GND}	Transmit Ground
2	TX_FAULT	Transmit Fault
3	$TX_DISABLE$	Transmit Disable
4	SDA	SDA Serial Data Signal
5	SCL	SCL Serial Clock Signal
6	MOD_ABS	Internal connected to ground
7	$RS0$	Rate select 0, not used
8	RX_LOS	Receiver Loss of Signal, LVTTTL High, open collector
9	$RS1$	Rate select 1, not used
10	R_{GND}	Receiver Ground
11	R_{GND}	Receiver Ground
12	$RX-$	Receive Data Bar, ac coupled
13	$RX+$	Receive Data, ac coupled
14	R_{GND}	Receiver Ground
15	V_{CCR}	Receiver Power Supply
16	V_{CCT}	Transmitter Power Supply
17	T_{GND}	Transmitter Ground
18	$TX+$	Transmit Data, ac coupled
19	$TX-$	Transmit Data Bar, ac coupled
20	T_{GND}	Transmitter Ground

ORDERING INFORMATION

PART NUMBER	OPERATING TEMPERATURE
CS3T2-25GF-3S-TC-L	0°C to 70°C
CS3T2-25GF-3S-TM-L	-20°C to 85°C

Note: The specifications subject to change without notice.

Lasermate Group, Inc.

19608 Camino De Rosa, Walnut, CA 91789, USA

Tel: (909)718-0999 | Fax: (909)718-0998 | E-mail: info@lasermate.com | URL: <http://www.lasermate.com>