



2.5Gbps 1270nm~1450nm SMF 26dB CWDM SFP Optical Transceiver with Duplex LC Connector

Model No. CS13xxD-48F-3U-TC-LD

Where **xx** value is as follows: **xx = 27** for 1270nm, **xx = 29** for 1290nm, **xx = 31** for 1310nm, **xx = 33** for 1330nm, **xx = 35** for 1350nm, **xx = 37** for 1370nm, **xx = 39** for 1390nm, **xx = 41** for 1410nm, **xx = 43** for 1430nm, **xx = 45** for 1450nm

FEATURES

- Compliant with SFF8472 diagnostic monitoring interface
- Industry standard small form pluggable (SFP) package
- Multi-Rate
- With APD
- Duplex LC connector
- Differential inputs and outputs
- Hot pluggable
- Class 1 laser product compliant with EN 60825-1
- Single power supply 3.3V
- TTL signal detect indicator
- Input/Output: AC/AC
- Operating case temperature range: 0°C to 70°C

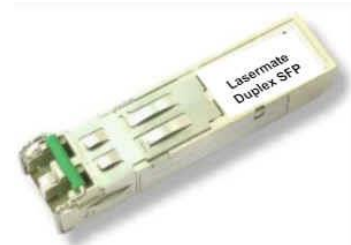

DIAGNOSTICS

PARAMETER	RANGE	ACCURACY	UNIT	CALIBRATION
Temperature	-10 to 85	±3	°C	External
Voltage	3.0 to 3.6	±0.1	V	
Bias Current	0 to 100	±5	mA	
TX Power	-2 to +3	±3 dB	dBm	
RX Power	-28 to -8	±3 dB	dBm	

ABSOLUTE MAXIMUM RATINGS

PARAMETER	SYMBOL	MIN	MAX	UNIT
Storage Temperature	T _s	-40	85	°C
Supply Voltage	V _{CC}	-0.5	4.0	V
Input Voltage	V _{IN}	-0.5	V _{CC}	V
Output Current	I _o	-	50	mA
Operating Current	I _{OP}	-	400	mA

RECOMMENDED OPERATING CONDITIONS

PARAMETER	SYMBOL	MIN	MAX	UNIT
Case Operating Temperature	T _c	0	70	°C
Supply Voltage	V _{CC}	3.1	3.5	V
Supply Current	I _{TX} + I _{RX}	-	300	mA

Lasermate Group, Inc.

19608 Camino De Rosa, Walnut, CA 91789, USA

Tel: (909)718-0999 | Fax: (909)718-0998 | E-mail: info@lasermate.com | URL: <http://www.lasermate.com>



TRANSMITTER ELECTRO-OPTICAL CHARACTERISTICS ($V_{CC} = 3.1V$ to $3.5V$, $T_C = 0^\circ C$ to $70^\circ C$)

PARAMETER	SYMBOL	MIN	TYP.	MAX	UNIT	NOTES
Output Optical Power 9/125um fiber	P_{out}	-2	-	+3	dBm	Average
Extinction Ratio	ER	8.2	-	-	dB	
Center Wavelength (1270nm)	λ_c	1264.5	-	1277.5	nm	
Center Wavelength (1290nm)		1284.5	-	1297.5		
Center Wavelength (1310nm)		1304.5	-	1317.5		
Center Wavelength (1330nm)		1324.5	-	1337.5		
Center Wavelength (1350nm)		1344.5	-	1357.5		
Center Wavelength (1370nm)		1364.5	-	1377.5		
Center Wavelength (1390nm)		1384.5	-	1397.5		
Center Wavelength (1410nm)		1404.5	-	1417.5		
Center Wavelength (1430nm)		1424.5	-	1437.5		
Center Wavelength (1450nm)		1444.5	-	1457.5		
Spectral Width (-20dB)	$\Delta\lambda$	-	-	0.7	nm	
Side Mode Suppression Ratio	SMSR	30			dB	
Output Eye	Compliant with Telcordia GR-253-CORE Issue 3 and ITU-T recommendation G-957					
Differential Input Voltage	V_{DIFF}	0.4	-	2.0	V	
Max. P_{out} TX-DISABLE Asserted	P_{OFF}	-	-	-45	dBm	
Optical Path Dispersion Penalty				2	dB	
Maximum Dispersion				1680	ps/nm	

RECEIVER ELECTRO-OPTICAL CHARACTERISTICS ($V_{CC} = 3.1V$ to $3.5V$, $T_C = 0^\circ C$ to $70^\circ C$)

PARAMETER	SYMBOL	MIN	TYP.	MAX	UNIT	NOTES
Optical Input Power – maximum	P_{IN}	-8	-	-	dBm	$BER < 10^{-12}$
RX Sensitivity @2.67 Gb/s	P_{IN}	-	-	-28	dBm	PRBS23, $BER < 10^{-10}$
RX Sensitivity @OC-48	P_{IN}	-	-	-28	dBm	PRBS23, $BER < 10^{-10}$
RX Sensitivity @2xFC	P_{IN}	-	-	-28	dBm	PRBS7, $BER < 10^{-12}$
RX Sensitivity @GbE	P_{IN}	-	-	-28	dBm	PRBS7, $BER < 10^{-12}$
RX Sensitivity @OC-12	P_{IN}	-	-	-28	dBm	PRBS23, $BER < 10^{-10}$
RX Sensitivity @OC-3	P_{IN}	-	-	-28	dBm	PRBS23, $BER < 10^{-10}$
RX Sensitivity @Fast Ethernet	P_{IN}	-	-	-28	dBm	PRBS7, $BER < 10^{-10}$
Operating Center Wavelength	λ_c	1260	-	1620	nm	
Optical Return Loss	ORL	-27	-	-	dB	
Signal Detect-Asserted	P_A	-	-	-28	dBm	
Signal Detect-Deasserted	P_D	-45	-	-	dBm	
Differential Output Voltage	V_{DIFF}	0.5	-	1.2	V	
Receiver Loss of Signal Output Voltage-Low	RX_LOS_L	0	-	0.5	V	
Receiver Loss of Signal Output-High	RX_LOS_H	2.4	-	V_{CC}	V	



BLOCK DIAGRAM OF TRANSCEIVER

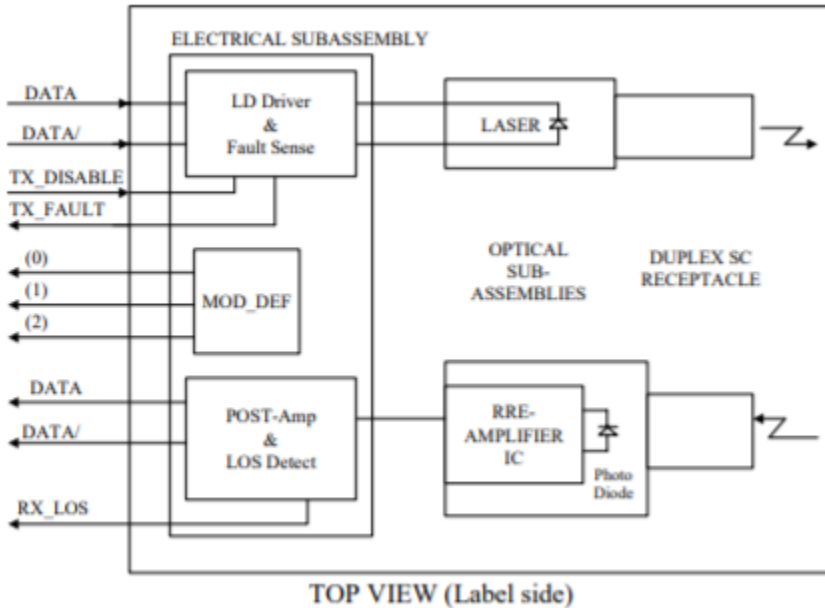

Transmitter Section - The transmitter section consists of a 1270~1450 nm InGaAsP laser in an eye safe optical subassembly (OSA) which mates to the fiber cable. The laser OSA is driven by a LD driver IC which converts differential input LVPECL logic signals into an analog laser driving current.

TX_DISABLE - The TX_DISABLE signal is high (TTL logic "1") to turn off the laser output. The laser will turn on when TX_DISABLE is low (TTL logic "0").

Receiver Section - The receiver utilizes an APD photodiode mounted together with a trans-impedance preamplifier IC in an OSA. This OSA is connected to a circuit providing post-amplification quantization, and optical signal detection.

Receive Loss (RX_LOS) - The RX_LOS is high (logic "1") when there is no incoming light from the companion transceiver. This signal is normally used by the system for the diagnostic purpose. The signal is operated in TTL level.

DIMENSIONS

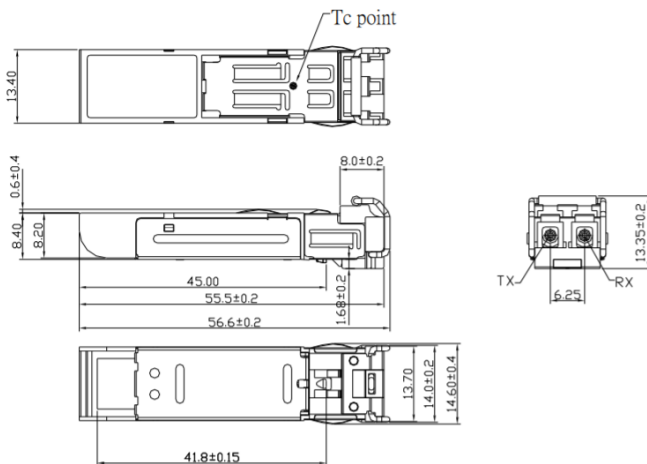

DIMENSIONS ARE IN MILLIMETERS

ALL DIMENSIONS ARE ± 0.1mm UNLESS OTHERWISE SPECIFIED

Lasermate Group, Inc.

19608 Camino De Rosa, Walnut, CA 91789, USA

Tel: (909)718-0999 | Fax: (909)718-0998 | E-mail: info@lasermate.com | URL: <http://www.lasermate.com>



SFP HOST BOARD MECHANICAL LAYOUT

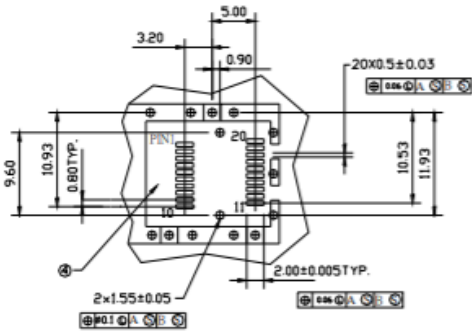
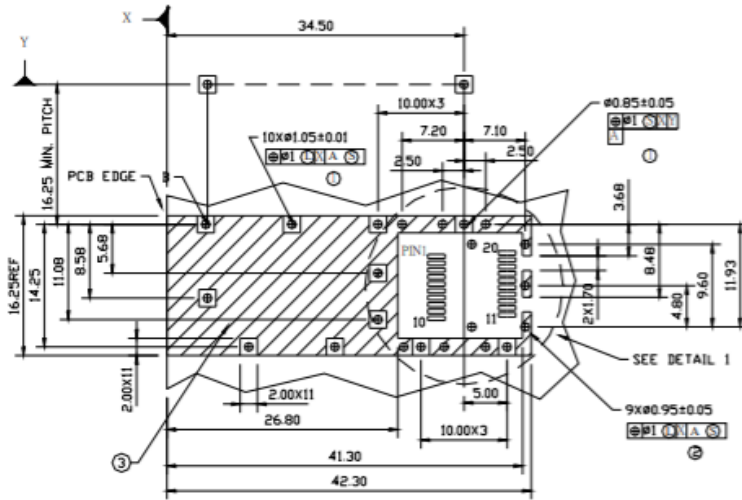

LEGEND

- 1.PADS AND VIAS ARE CHASSIS GROUND
- 2.THROUGH HOLES, PLATING OPTIONAL
- 3.HATCHED AREA DENOTES COMPONENT AND TRACE KEEPOUT(EXCEPT CHASSIS GROUND)
- 4.AREA DENOTES COMPONENT KEEPOUT (TRACES ALLOWED)

DIMENSIONS ARE IN MILLIMETERS

ASSEMBLY DRAWING (unit: mm)

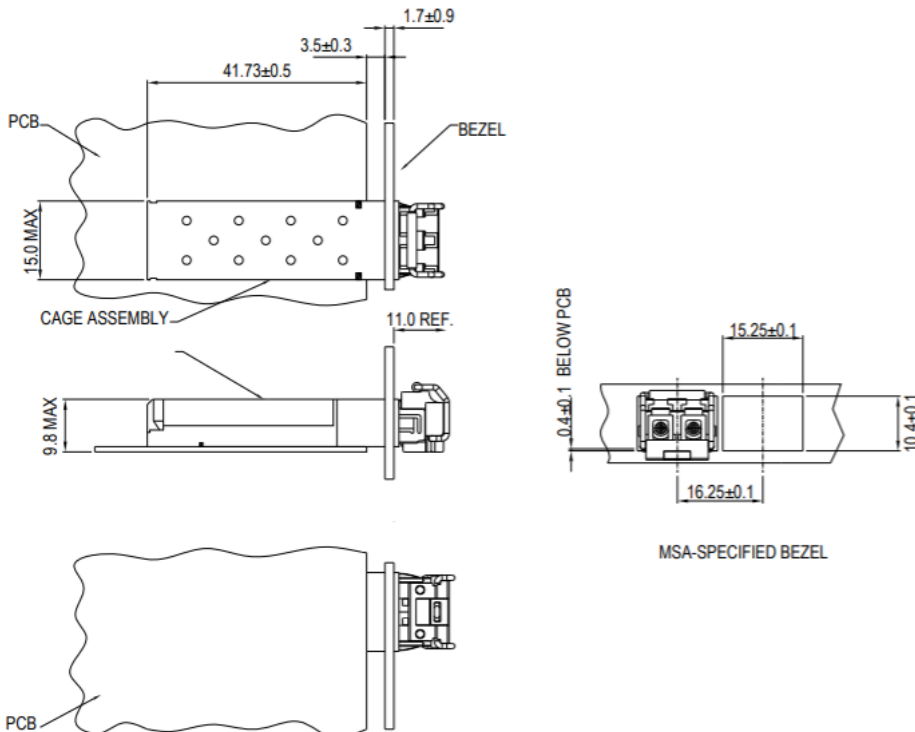

Lasermate Group, Inc.

19608 Camino De Rosa, Walnut, CA 91789, USA

Tel: (909)718-0999 | Fax: (909)718-0998 | E-mail: info@lasermate.com | URL: <http://www.lasermate.com>



PIN ASSIGNMENT

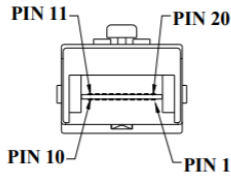

PIN	SIGNAL NAME	DESCRIPTION	PIN	SIGNAL NAME	DESCRIPTION
1	T _{GND}	Transmit Ground	11	R _{GND}	Receiver Ground
2	TX_FAULT	Transmit Fault	12	RX-	Receive Data Bar, Differential PECL, ac coupled
3	TX_DISABLE	Transmit Disable	13	RX+	Receive Data, Differential PECL, ac coupled
4	MOD_DEF (2)	SDA Serial Data Signal	14	R _{GND}	Receiver Ground
5	MOD_DEF (1)	SCL Serial Clock Signal	15	V _{CCR}	Receiver Power Supply
6	MOD_DEF (0)	TTL Low	16	V _{CCT}	Transmitter Power Supply
7	RATE SELECT	Open Circuit	17	T _{GND}	Transmitter Ground
8	RX_LOS	Receiver Loss of Signal, TTL High, open collector	18	TX+	Transmit Data, Differential PECL, ac coupled
9	R _{GND}	Receiver Ground	19	TX-	Transmit Data Bar, Differential PECL, ac coupled
10	R _{GND}	Receiver Ground	20	T _{GND}	Transmitter Ground

EYE SAFETY MARK

The single-mode transceiver is a class 1 laser product. It complies with EN 60825-1 and FDA 21 CFR 1040.10 and 1040.11. In order to meet laser safety requirements, the transceiver shall be operated within the Absolute Maximum Ratings.

Required Mark

**Class 1 Laser Product
Complies with
21 CFR 1040.10 and 1040.11**

[Caution] All adjustments have been done at the factory before the shipment of the devices. No maintenance and user serviceable part is required. Tampering with and modifying the performance of the device will result in voided product warranty.

Note: The specifications subject to change without notice.