



# 1.25Gbps 1270nm~1450nm SMF 27dB CWDM SFP Optical Transceiver with Duplex LC Connector

Model No. CS13xxD-24F-3U1-TC-LD

Where **xx** value is as follows: **xx = 27** for 1270nm, **xx = 29** for 1290nm, **xx = 31** for 1310nm, **xx = 33** for 1330nm, **xx = 35** for 1350nm, **xx = 37** for 1370nm, **xx = 39** for 1390nm, **xx = 41** for 1410nm, **xx = 43** for 1430nm, **xx = 45** for 1450nm

## FEATURES

- Compliant with IEEE802.3z Gigabit Ethernet Standard
- Compliant with Fiber Channel 100-SM-LC-L standard
- Compliant with SFF8472 diagnostic monitoring interface
- Industry standard small form pluggable (SFP) package
- Duplex LC connector
- Differential PECL inputs and outputs
- Hot pluggable
- Class 1 laser product compliant with EN 60825-1
- Single power supply 3.3V
- TTL signal detect indicator
- Input/Output: AC/AC
- Operating case temperature range: 0°C to 70°C

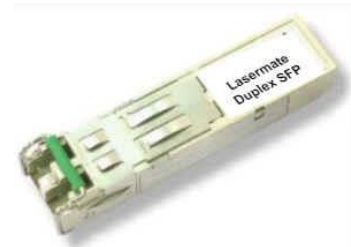

## DIAGNOSTICS

PARAMETER	RANGE	ACCURACY	UNIT	CALIBRATION
Temperature	-40 to 95	±3	°C	External
Voltage	0 to VCC	±0.1	V	
Bias Current	0 to 120	±5	mA	
TX Power	-3 to +8	±3 dB	dBm	
RX Power	-24 to -3	±3 dB	dBm	

## ABSOLUTE MAXIMUM RATINGS

PARAMETER	SYMBOL	MIN	MAX	UNIT
Storage Temperature	T <sub>S</sub>	-40	85	°C
Supply Voltage	V <sub>CC</sub>	-0.5	4.0	V
Input Voltage	V <sub>IN</sub>	-0.5	V <sub>CC</sub>	V
Output Current	I <sub>O</sub>	-	50	mA
Operating Current	I <sub>OP</sub>	-	400	mA

## RECOMMENDED OPERATING CONDITIONS

PARAMETER	SYMBOL	MIN	MAX	UNIT
Case Operating Temperature	T <sub>C</sub>	0	70	°C
Supply Voltage	V <sub>CC</sub>	3.1	3.5	V
Supply Current	I <sub>TX</sub> + I <sub>RX</sub>	-	300	mA

**Lasermate Group, Inc.**

19608 Camino De Rosa, Walnut, CA 91789, USA

Tel: (909)718-0999 | Fax: (909)718-0998 | E-mail: [info@lasermate.com](mailto:info@lasermate.com) | URL: <http://www.lasermate.com>

**TRANSMITTER ELECTRO-OPTICAL CHARACTERISTICS ( $V_{CC} = 3.1V$  to  $3.5V$ ,  $T_C = 0^\circ C$  to  $70^\circ C$ )**

PARAMETER	SYMBOL	MIN	TYP.	MAX	UNIT	NOTES	
Output Optical Power 9/125um fiber	$P_{out}$	0	+2	+5	dBm	Average	
Extinction Ratio	ER	7	-	-	dB		
Center Wavelength (1270nm)	$\lambda_c$	1264.5	-	1277.5	nm		
Center Wavelength (1290nm)		1284.5	-	1297.5			
Center Wavelength (1310nm)		1304.5	-	1317.5			
Center Wavelength (1330nm)		1324.5	-	1337.5			
Center Wavelength (1350nm)		1344.5	-	1357.5			
Center Wavelength (1370nm)		1364.5	-	1377.5			
Center Wavelength (1390nm)		1384.5	-	1397.5			
Center Wavelength (1410nm)		1404.5	-	1417.5			
Center Wavelength (1430nm)		1424.5	-	1437.5			
Center Wavelength (1450nm)		1444.5	-	1457.5			
Spectral Width (-20dB)	$\Delta\lambda$	-	-	1	nm		
Side Mode Suppression Ratio	SMSR	30			dB		
Rise/Fall Time, (20~80%)	$T_{r,f}$	-	-	260	ps		
Relative Intensity Noise	RIN	-	-	-120	dB/Hz		
Total Jitter	TJ	-	-	227	ps		
Output Eye		Compliant with IEEE802.3ae					
Differential Input Voltage	$V_{DIFF}$	0.4	-	2.0	V		
Max. $P_{out}$ TX-DISABLE Asserted	$P_{OFF}$	-	-	-45	dBm		

**RECEIVER ELECTRO-OPTICAL CHARACTERISTICS ( $V_{CC} = 3.1V$  to  $3.5V$ ,  $T_C = 0^\circ C$  to  $70^\circ C$ )**

PARAMETER	SYMBOL	MIN	TYP.	MAX	UNIT	NOTES
Optical Input Power – maximum	$P_{IN}$	-1	-	-	dBm	BER<10 <sup>-12</sup>
Optical Input Power – minimum (Sensitivity)	$P_{IN}$	-	-29	-27	dBm	BER<10 <sup>-12</sup>
Operating Center Wavelength	$\lambda_c$	1260	-	1620	nm	
Optical Return Loss	ORL	12	-	-	dB	
Signal Detect-Asserted	$P_A$	-	-	-27	dBm	
Signal Detect-Deasserted	$P_D$	-40	-	-	dBm	
Differential Output Voltage	$V_{DIFF}$	0.5	-	1.2	V	
Data Output Rise, Fall Time (20~80%)	$T_{r,f}$	-	-	0.35	ns	
Receiver Loss of Signal Output Voltage-Low	RX_LOS <sub>L</sub>	0	-	0.5	V	
Receiver Loss of Signal Output-High	RX_LOS <sub>H</sub>	2.4	-	$V_{CC}$	V	



**BLOCK DIAGRAM OF TRANSCEIVER**

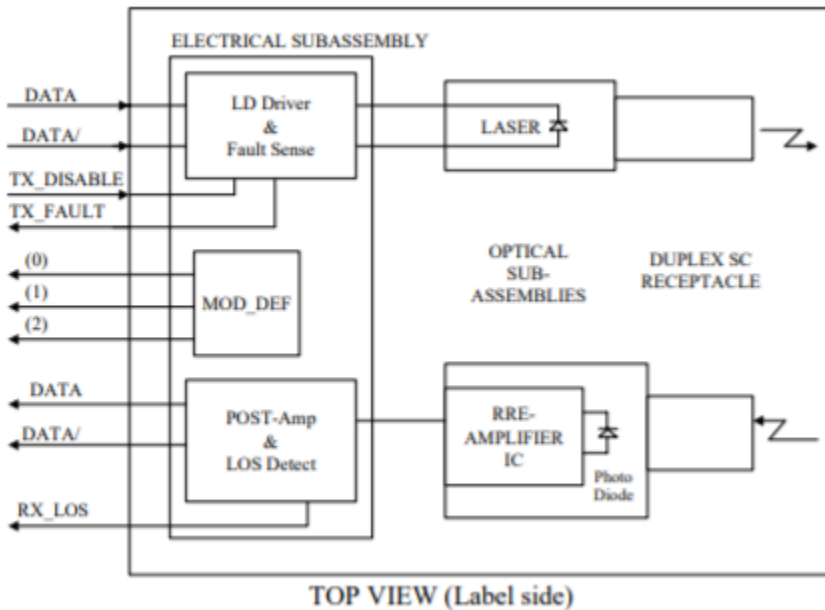

**Transmitter Section** - The transmitter section consists of a 1310 nm InGaAsP laser in an eye safe optical subassembly (OSA) which mates to the fiber cable. The laser OSA is driven by a LD driver IC which converts differential input LVPECL logic signals into an analog laser driving current.

**TX\_DISABLE** - The TX\_DISABLE signal is high (TTL logic "1") to turn off the laser output. The laser will turn on when TX\_DISABLE is low (TTL logic "0").

**Receiver Section** - The receiver utilizes an InGaAs PIN photodiode mounted together with a trans-impedance preamplifier IC in an OSA. This OSA is connected to a circuit providing post-amplification quantization, and optical signal detection.

**Receive Loss (RX\_LOS)** - The RX\_LOS is high (logic "1") when there is no incoming light from the companion transceiver. This signal is normally used by the system for the diagnostic purpose. The signal is operated in LVTTTL level.

**DIMENSIONS**

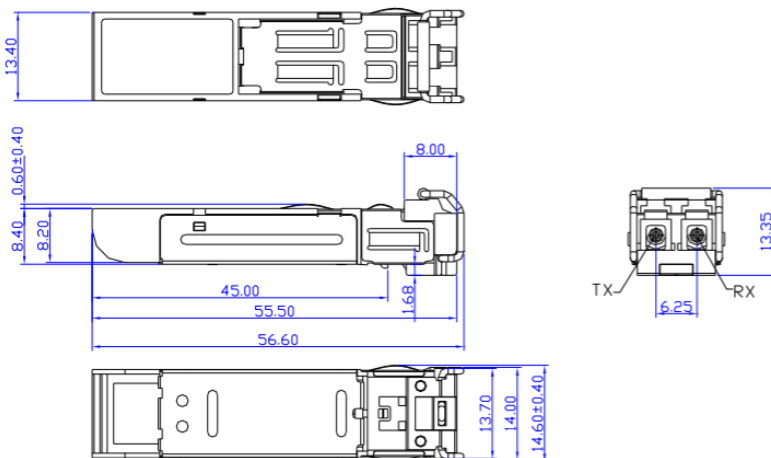

**DIMENSIONS ARE IN MILLIMETERS**

**ALL DIMENSIONS ARE ± 0.2mm UNLESS OTHERWISE SPECIFIED**

**Lasermate Group, Inc.**

19608 Camino De Rosa, Walnut, CA 91789, USA

Tel: (909)718-0999 | Fax: (909)718-0998 | E-mail: info@lasermate.com | URL: <http://www.lasermate.com>



**SFP HOST BOARD MECHANICAL LAYOUT**

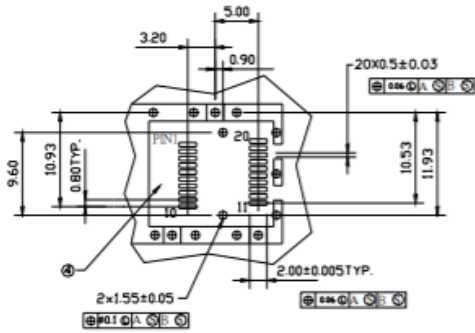
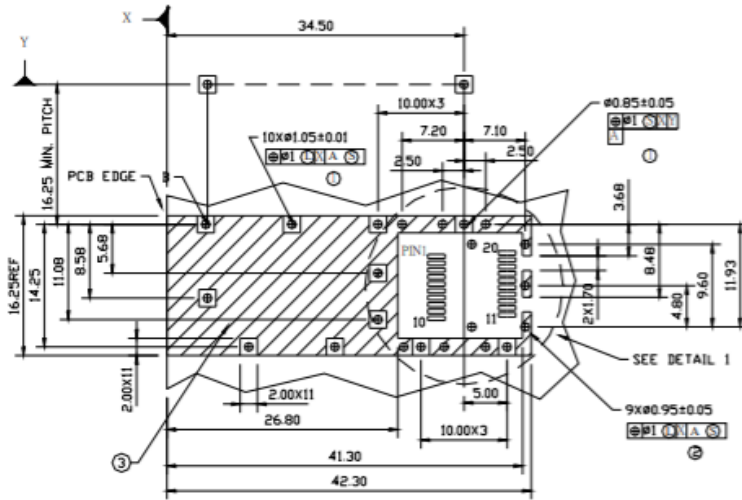

**LEGEND**

1. PADS AND VIAS ARE CHASSIS GROUND
2. THROUGH HOLES, PLATING OPTIONAL
3. HATCHED AREA DENOTES COMPONENT AND TRACE KEEPOUT (EXCEPT CHASSIS GROUND)
4. AREA DENOTES COMPONENT KEEPOUT (TRACES ALLOWED)

DIMENSIONS ARE IN MILLIMETERS

**ASSEMBLY DRAWING (unit: mm)**

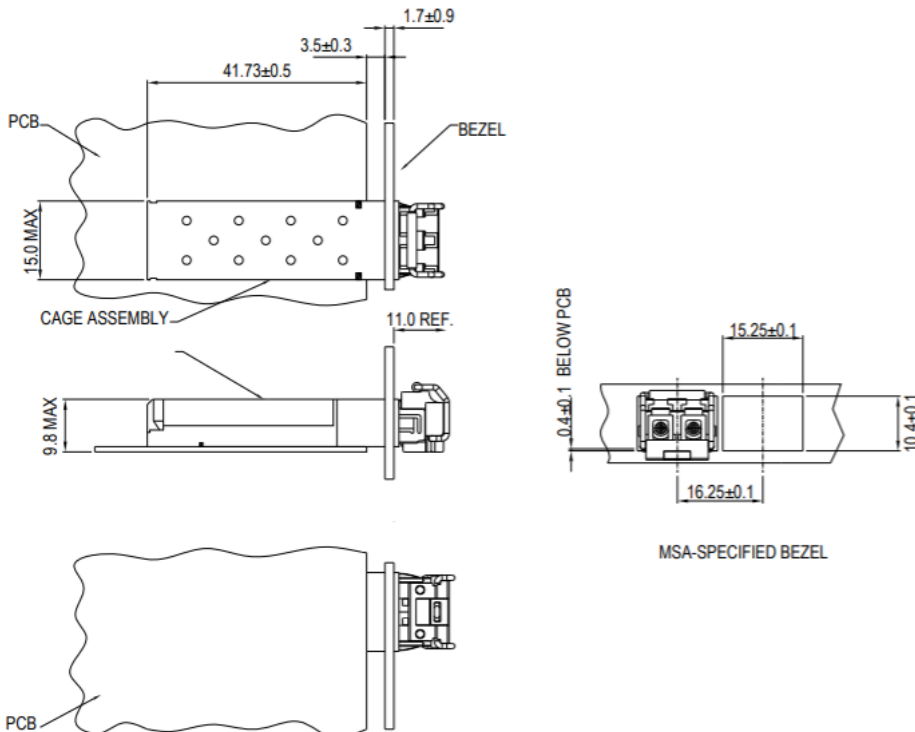

MSA-SPECIFIED BEZEL



## PIN ASSIGNMENT

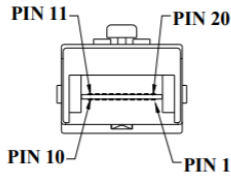

PIN	SIGNAL NAME	DESCRIPTION	PIN	SIGNAL NAME	DESCRIPTION
1	T <sub>GND</sub>	Transmit Ground	11	R <sub>GND</sub>	Receiver Ground
2	TX_FAULT	Transmit Fault	12	RX-	Receive Data Bar, Differential PECL, ac coupled
3	TX_DISABLE	Transmit Disable	13	RX+	Receive Data, Differential PECL, ac coupled
4	MOD_DEF (2)	SDA Serial Data Signal	14	R <sub>GND</sub>	Receiver Ground
5	MOD_DEF (1)	SCL Serial Clock Signal	15	V <sub>CCR</sub>	Receiver Power Supply
6	MOD_DEF (0)	TTL Low	16	V <sub>CCT</sub>	Transmitter Power Supply
7	RATE SELECT	Open Circuit	17	T <sub>GND</sub>	Transmitter Ground
8	RX_LOS	Receiver Loss of Signal, TTL High, open collector	18	TX+	Transmit Data, Differential PECL, ac coupled
9	R <sub>GND</sub>	Receiver Ground	19	TX-	Transmit Data Bar, Differential PECL, ac coupled
10	R <sub>GND</sub>	Receiver Ground	20	T <sub>GND</sub>	Transmitter Ground

## EYE SAFETY MARK

The single-mode transceiver is a class 1 laser product. It complies with EN 60825-1 and FDA 21 CFR 1040.10 and 1040.11. In order to meet laser safety requirements, the transceiver shall be operated within the Absolute Maximum Ratings.

## Required Mark

**Class 1 Laser Product  
Complies with  
21 CFR 1040.10 and 1040.11**

**[Caution]** All adjustments have been done at the factory before the shipment of the devices. No maintenance and user serviceable part is required. Tampering with and modifying the performance of the device will result in voided product warranty.



**ORDERING INFORMATION**

<b>PART NUMBER</b>	<b>WAVELENGTH</b>	<b>OPERATING TEMPERATURE</b>
CS1327D-24F-3U1-TC-LD	1270nm	0°C to 70°C
CS1329D-24F-3U1-TC-LD	1290nm	0°C to 70°C
CS1331D-24F-3U1-TC-LD	1310nm	0°C to 70°C
CS1333D-24F-3U1-TC-LD	1330nm	0°C to 70°C
CS1335D-24F-3U1-TC-LD	1350nm	0°C to 70°C
CS1337D-24F-3U1-TC-LD	1370nm	0°C to 70°C
CS1339D-24F-3U1-TC-LD	1390nm	0°C to 70°C
CS1341D-24F-3U1-TC-LD	1410nm	0°C to 70°C
CS1343D-24F-3U1-TC-LD	1430nm	0°C to 70°C
CS1345D-24F-3U1-TC-LD	1450nm	0°C to 70°C

**Note:** The specifications subject to change without notice.