



10GFC 10GBASE-LR/LW SONET SDH ITU-T G.709 1310nm SMF 10km XFP (10Gbps SFP) Optical Transceiver with Duplex LC Connector

Model No. CS13D-X-3S1-Tx-L

FEATURES

- Compliant with 10GFC 1200-SM-LL-L Fiber Channel standard
- Compliant with IEEE802.3ae 10GBASE-LW/LR Ethernet standard
- Compliant with SONET OC-192 SR-1 SDH STM I-64.1
- Compliant with 10GE over ITU G.709
- Compliant with ITU G.709
- Compliant with XFP MSA INF-8077i
- Differential LVPECL inputs and CML outputs
- Hot pluggable
- Single power supply 3.3V
- TTL signal detect indicator
- Class 1 laser product compliant with EN 60825-1
- Input/Output: AC/AC



ABSOLUTE MAXIMUM RATINGS

PARAMETER	SYMBOL	MIN	MAX	UNIT
Storage Temperature	T _S	-40	85	°C
Supply Voltage	V _{CC}	-0.5	4.0	V
Input Voltage	V _{IN}	-0.5	V _{CC}	V

RECOMMENDED OPERATING CONDITIONS

PARAMETER	SYMBOL	MIN	MAX	UNIT	NOTES
Case Operating Temperature	T _C	0	70	°C	CS13D-X-3S1-TC-L
		-25	85		CS13D-X-3S1-TM-L
Supply Voltage	V _{CC}	3.1	3.5	V	
Supply Current	I _{TX} + I _{RX}	-	500	mA	

DIAGNOSTICS

DATA ADDRESS	PARAMETER	RANGE	ACCURACY
96-97	Temperature	-35 to 95°C	±3°C
100-101	Bias Current	0 to 100mA	±10%
102-103	TX Power	-8 to +2.5dBm	±2dB
104-105	RX Power	-16.5 to +1.5dBm	±2dB
106-107	Vcc3 Voltage	2.9-3.7Volts	±3%

Lasermate Group, Inc.

19608 Camino De Rosa, Walnut, CA 91789, USA

Tel: (909)718-0999 | Fax: (909)718-0998 | E-mail: info@lasermate.com | URL: <http://www.lasermate.com>



TRANSMITTER ELECTRO-OPTICAL CHARACTERISTICS ($V_{CC} = 3.1V$ to $3.5V$, $T_C = 0$ to $70^\circ C$, -25 to $85^\circ C$)

PARAMETER	SYMBOL	MIN	TYP.	MAX	UNIT	NOTES
Operating Data Rate	D	9.95		11.3	Gbps	
Input Reference Clock Rate		Not required				
Output Optical Power	P_{out}	-6	-	-1	dBm	
Extinction Ratio	ER	6	-	-	dB	
Center Wavelength	λ_C	1290		1330	nm	
Side Mode Suppression Ratio	SSR_{min}	30			dB	
Relative Intensity Noise	RIN	-	-	-130	dB/Hz	
Output Eye		Compliant with IEEE802.3ae				
Differential Input Voltage	V_{DIFF}	0.25	-	1.0	V	
Transmit Fault Output-Low	TX_FAULT_L	0.0	-	0.5	V	
Transmit Fault Output-High	TX_FAULT_H	2.4	-	V_{CC}	V	
TX_DISABLE Assert Time	t_{off}	-	-	10	us	
TX_DISABLE Negate Time	t_{on}	-	-	2	ms	
Time to initialize	t_{init}	-	-	300	ms	
Interrupt assert delay	$\overline{Interrupt_on}$	-	-	200	ms	
Interrupt negate delay	$\overline{Interrupt_off}$	-	-	500	us	
P_Down/RST assert delay	P_Down/RST_on			100	us	
Mod_NR assert delay	Mod_nr_on			1	ms	
Mod_NR negate delay	Mod_nr_off			1	ms	
P-Down reset time		10			us	
RX_LOS assert delay	t_{loss_on}			100	us	
RX_LOS negate delay	t_{loss_off}			100	us	

RECEIVER ELECTRO-OPTICAL CHARACTERISTICS ($V_{CC} = 3.1V$ to $3.5V$, $T_C = 0$ to $70^\circ C$, -25 to $85^\circ C$)

PARAMETER	SYMBOL	MIN	TYP.	MAX	UNIT	NOTES
Receiver Sensitivity	P_{IN}	-14.4	-	0.5	dBm	$BER < 10^{-12}$
Receiver Sensitivity in OMA	P_{IN}	-	-	-12.6	dBm	$BER < 10^{-12}$
Stress Receiver Sensitivity in OMA	P_{IN}	-	-	-10.3	dBm	$BER < 10^{-12}$
Operating Center Wavelength	λ_C	1270	-	1600	nm	
Optical Return Loss	ORL	12	-	-	dB	
Loss of Signal-Asserted	P_A	-	-	-30	dBm	
Loss of Signal-Deasserted	P_D	-18	-	-	dBm	
Differential Output Voltage	V_{DIFF}	0.5	0.65	0.8	V	
TTL Input High Voltage		2		V_{CC}	V	
TTL Input Low Voltage		0		0.8	V	
TTL Output High Voltage		2.4	-	V_{CC}	V	
TTL Output Low Voltage		0	-	0.4	V	
Receiver Loss of Signal Assert Time (off to on)	t_{A,RX_LOS}	-	-	100	us	
Receiver Loss of Signal Assert Time (on to off)	t_{D,RX_LOS}	-	-	100	us	



BLOCK DIAGRAM OF TRANSCEIVER

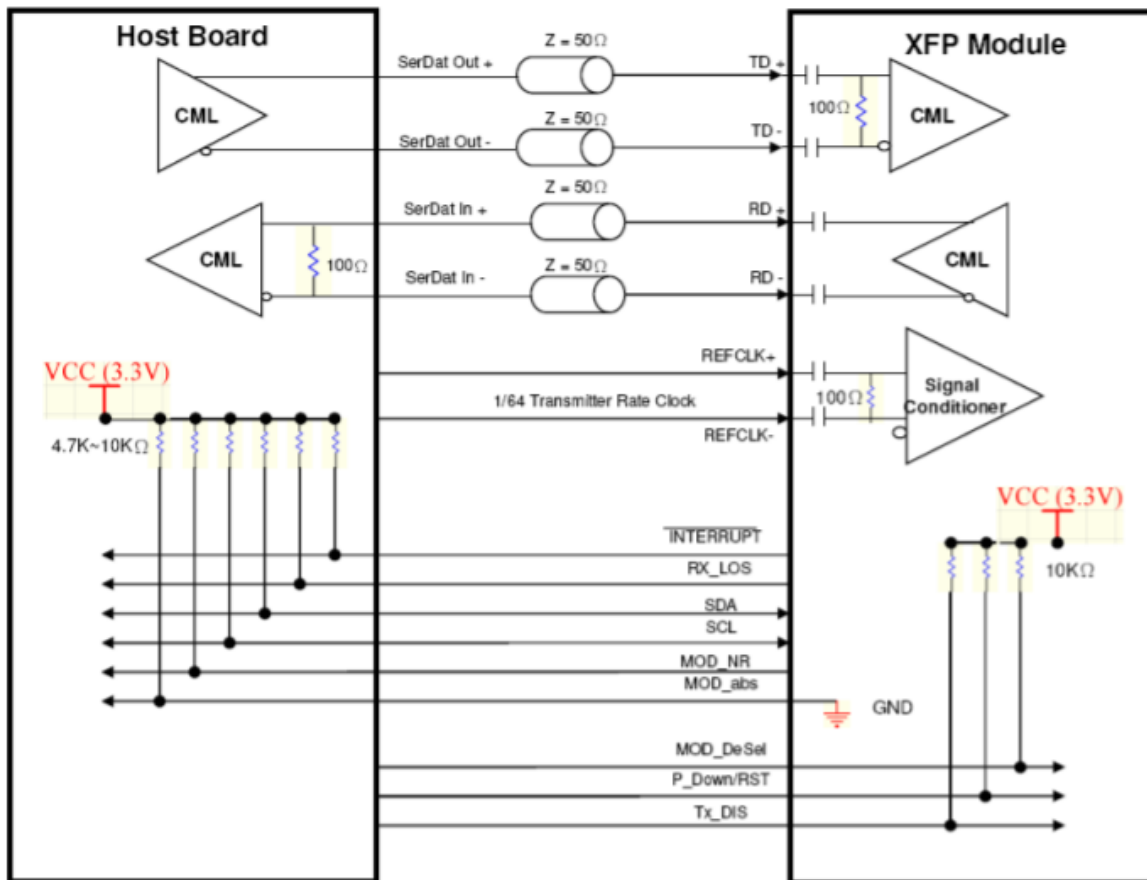

MOD_NR

The Mod_NR is an output pin that when High, indicates that the module has detected a condition that renders transmitter and or receiver data invalid, shall consist of logical OR of the following signals:

- Transmit Signal Conditioner Loss of Lock
- Transmitter Laser Fault
- Receiver Signal Conditioner Loss of Lock

MOD_DESEL

The Mod_DeSel is an input pin. When held Low by the host, the module responds to 2-wire serial communication commands. The Mod_DeSel allows the use of multiple XFP modules on a single 2-wire interface bus. When the Mod_DeSel pin is "High", the module shall not respond to or acknowledge any 2-wire interface communication from the host.

Interrupt

Interrupt is an output pin. When "Low", indicates possible module operational fault or a status critical to the host system.



TX_DIS

TX_DIS is an input pin. When TX_DIS is asserted High, the XFP module transmitter output must be turned off.

MOD_ABS

Mod_ABS is pulled up to Host_Vcc on the host board and grounded in the XFP module. Mod_ABS is then asserted “High” when the XFP module is physically absent from a host slot.

RX_LOS

The RX_LOS when High indicates insufficient optical power for reliable signal reception.

P_DOWN/RST

This is a multifunction pin for module Power Down and Reset. The P_Down/RST pin must be pulled up to VCC3 in the XFP module.

POWER DOWN FUNCTION

The P_Down pin, when held High by the host, places the module in the standby (Low Power) mode with a maximum power dissipation of 1.5W. This protects hosts which are not capable of cooling higher power modules which may be accidentally inserted.



DIMENSIONS

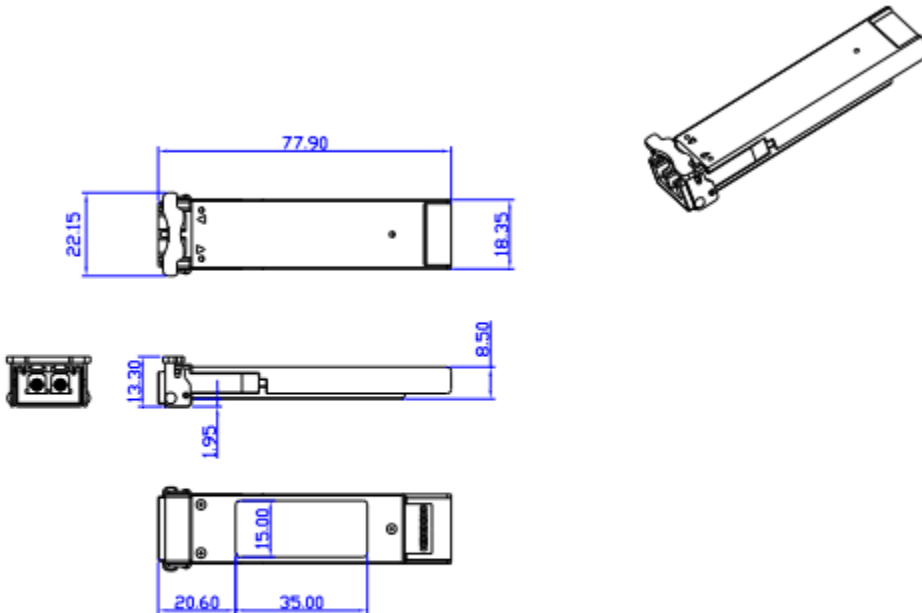

DIMENSIONS ARE IN MILLIMETERS

ALL DIMENSIONS ARE ±0.2mm UNLESS OTHERWISE SPECIFIED

PIN ASSIGNMENT

16	GND	GND	15
17	RD-	RX_LOS	14
18	RD+	MOD_NR	13
19	GND	MOD_ABS	12
20	VCC2	SDA	11
21	P_DOWN/RST	SCL	10
22	VCC2	VCC3	9
23	GND	VCC3	8
24	REFCLK+	GND	7
25	REFCLK-	VCC5	6
26	GND	TX_DIS	5
27	GND	INTERRUPT	4
28	TD-	MOD_DESEL	3
29	TD+	VEE5	2
30	GND	GND	1

← TOWARD ASIC TOWARD BEZEL →



<i>Pin</i>	<i>Logic</i>	<i>Symbol</i>	<i>Name/Description</i>	<i>Note</i>
1		GND	Module Ground	1
2		VEE5	Optional -5.2V Power Supply	
3	LVTTL-I	Mod_DeSel	Module De-select; When held low allows module to respond to 2-wire serial interface	
4	LVTTL-O	$\bar{\text{Interrupt}}$	$\bar{\text{Interrupt}}$; Indicates presence of an important condition which can be read over the 2-wire serial interface	2
5	LVTTL-I	TX_DIS	Transmitter Disable; Turns off transmitter laser output	
6		VCC5	+5V Power Supply	
7		GND	Module Ground	1
8		VCC3	+3.3V Power Supply	
9		VCC3	+3.3V Power Supply	
10	LVTTL-I/O	SCL	2-Wire Serial Interface Clock	2
11	LVTTL-I/O	SDA	2-Wire Serial Interface Data Line	2
12	LVTTL-O	Mod_Abs	Indicates Module is not present. Grounded in the Module	2
13	LVTTL-O	Mod_NR	Module Not Ready; Indicating Module Operational Fault	2
14	LVTTL-O	RX_LOS	Receiver Loss Of Signal Indicator	2
15		GND	Module Ground	1
16		GND	Module Ground	1
17	CML-O	RD-	Receiver Inverted Data Output	
18	CML-O	RD+	Receiver Non-Inverted Data Output	
19		GND	Module Ground	1
20		VCC2	+1.8V Power Supply	3
21	LVTTL-I	P_Down/RST	Power down; When high, requires the module to limit power consumption to 1.5W or below. 2-Wire serial interface must be functional in the low power mode. Reset; The falling edge initiates a complete reset of the module including the 2-wire serial interface, equivalent to a power cycle.	
22		VCC2	+1.8V Power Supply	3
23		GND	Module Ground	1
24	PECL-I	RefCLK+	Reference Clock Non-Inverted Input, AC coupled on the host board	
25	PECL-I	RefCLK-	Reference Clock Inverted Input, AC coupled on the host board	
26		GND	Module Ground	1
27		GND	Module Ground	1
28	CML-I	TD-	Transmitter Inverted Data Input	
29	CML-I	TD+	Transmitter Non-Inverted Data Input	
30		GND	Module Ground	1

1. Module ground pins Gnd are isolated from the module case and chassis ground within the module.
 2. Shall be pulled up with 4.7K-10Kohms to a voltage between 3.15V and 3.45V on the host board.
 3. The 1.8 V power supply can be optionally programmed to voltages lower than 1.8 V in modules supporting the variable power supply.



EYE SAFETY MARK

The single mode transceiver is a class 1 laser product. It complies with EN 60825-1 and FDA 21 CFR 1040.10 and 1040.11. In order to meet laser safety requirements, the transceiver shall be operated within the Absolute Maximum Ratings.

Required Mark

Class 1 Laser Product
Complies with
21 CFR 1040.10 and 1040.11

[Caution] All adjustments have been done at the factory before the shipment of the devices. No maintenance and user serviceable part is required. Tampering with and modifying the performance of the device will result in voided product warranty.

ORDERING INFORMATION

PART NUMBER	INPUT/OUTPUT	SIGNAL DETECT	VOLTAGE	OPERATING TEMPERATURE
CS13D-X-3S1-TC-L	AC/AC	TTL	3.3V	0 to 70°C
CS13D-X-3S1-TM-L	AC/AC	TTL	3.3V	-25 to 85°C

Note: The specifications subject to change without notice.