



622Mbps 1310nm SMF 50km SFP Optical Transceiver with Duplex LC Connector

Model No. CS13D-12F-3L-Tx-LD

FEATURES

- Compliant with SONET/SDH application
- Industry standard small form pluggable (SFP) package
- Hot pluggable
- Single power supply 3.3V
- Duplex LC connector
- Differential LVPECL inputs and outputs
- TTL signal detect indicator
- Class 1 laser product compliant with EN 60825-1
- Input/Output: AC/AC
- Distance: 50km

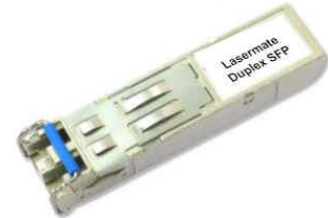

DIAGNOSTICS

PARAMETER	RANGE	ACCURACY	UNIT	CALIBRATION
Temperature	-40 to 95	±3	°C	External
Voltage	0 to VCC	±0.1	V	
Bias Current	0 to 120	±5	mA	
TX Power	-5 to +4	±3 dB	dBm	
RX Power	-28 to -8	±3 dB	dBm	

ABSOLUTE MAXIMUM RATINGS

PARAMETER	SYMBOL	MIN	MAX	UNIT
Storage Temperature	T _S	-40	85	°C
Supply Voltage	V _{CC}	-0.5	4.0	V
Input Voltage	V _{IN}	-0.5	V _{CC}	V
Output Current	I _O	-	50	mA
Operating Current	I _{OP}	-	400	mA

RECOMMENDED OPERATING CONDITIONS

PARAMETER	SYMBOL	MIN	MAX	UNIT	NOTES
Case Operating Temperature	T _C	0	70	°C	CS13D-12F-3L-TC-LD
		-40	85		CS13D-12F-3L-TI-LD
Supply Voltage	V _{CC}	3.1	3.5	V	
Supply Current	I _{TX} + I _{RX}	-	300	mA	

**TRANSMITTER ELECTRO-OPTICAL CHARACTERISTICS ($V_{CC} = 3.1V$ to $3.5V$, $T_C = 0^{\circ}C$ to $70^{\circ}C$, $-40^{\circ}C$ to $85^{\circ}C$)**

PARAMETER	SYMBOL	MIN	TYP.	MAX	UNIT	NOTES
Data Rate	B	-	622	700	Mbps	
Output Optical Power 9/125um fiber	P_{out}	-3	-	+2	dBm	Average
Extinction Ratio	ER	10	-	-	dB	
Center Wavelength	λ_c	1280	1310	1335	nm	
Spectral Width (-20dB)	$\Delta\lambda$	-	-	1	nm	
Rise/Fall Time (20~80%)	$T_{r,f}$	-	-	0.5	ns	
Output Eye	Compliant with Telcordia GR-253-CORE Issue 3 and ITU-T recommendation G-957					
Differential Input Voltage	V_{DIFF}	0.4	-	2.0	V	

RECEIVER ELECTRO-OPTICAL CHARACTERISTICS ($V_{CC} = 3.1V$ to $3.5V$, $T_C = 0^{\circ}C$ to $70^{\circ}C$, $-40^{\circ}C$ to $85^{\circ}C$)

PARAMETER	SYMBOL	MIN	TYP.	MAX	UNIT	NOTES
Data Rate	B		622	700	Mbps	
Optical Input Power-Maximum	P_{IN}	-3	-	-	dBm	PRBS23, BER<10 ⁻¹⁰
RX Sensitivity @OC-12	P_{IN}	-	-	-28	dBm	PRBS23, BER<10 ⁻¹⁰
Operating Center Wavelength	λ_c	1260	-	1600	nm	
Loss of Signal-Asserted	P_A	-	-	-28	dBm	Average
Loss of Signal-Deasserted	P_D	-45	-	-	dBm	Average
Loss of Signal-Hysteresis	P_A-P_D	1.0	-	-	dB	
Data Output Rise, Fall time (20~80%)	$T_{r,f}$	-	-	0.5	ns	
Differential Output Voltage	V_{DIFF}	0.5	-	1.2	V	
Receiver Loss of Signal Output Voltage-Low	RX_LOS _L	0	-	0.5	V	
Receiver Loss of Signal Output Voltage-High	RX_LOS _H	2.4	-	V_{CC}	V	



BLOCK DIAGRAM OF TRANSCEIVER

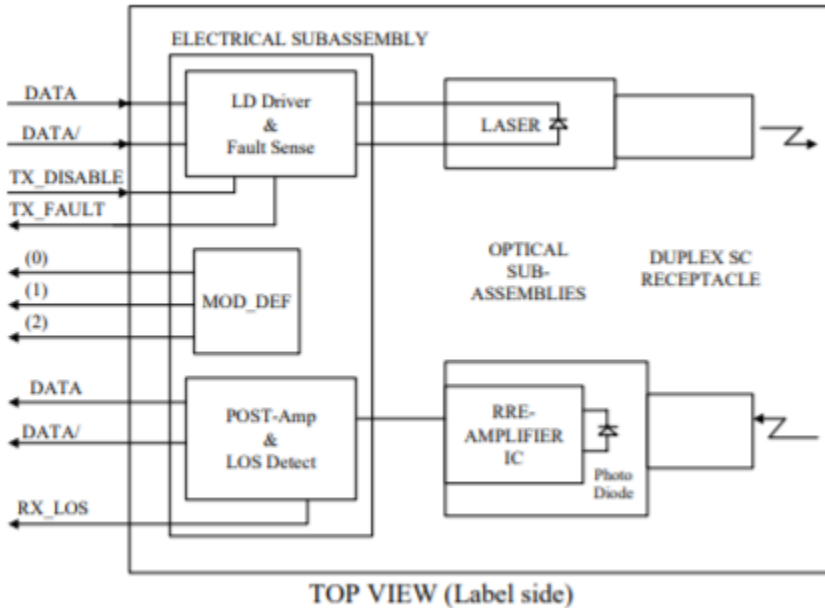

Transmitter Section - The transmitter section consists of a 1310 nm InGaAsP laser in an eye safe optical subassembly (OSA) which mates to the fiber cable. The laser OSA is driven by a LD driver IC which converts differential input LVPECL logic signals into an analog laser driving current.

TX_DISABLE - The TX_DISABLE signal is high (TTL logic "1") to turn off the laser output. The laser will turn on when TX_DISABLE is low (TTL logic "0").

Receiver Section - The receiver utilizes an InGaAs PIN photodiode mounted together with a trans-impedance preamplifier IC in an OSA. This OSA is connected to a circuit providing post-amplification quantization, and optical signal detection.

Receive Loss (RX_LOS) - The RX_LOS is high (logic "1") when there is no incoming light from the companion transceiver. This signal is normally used by the system for the diagnostic purpose. The signal is operated in TTL level.

DIMENSIONS

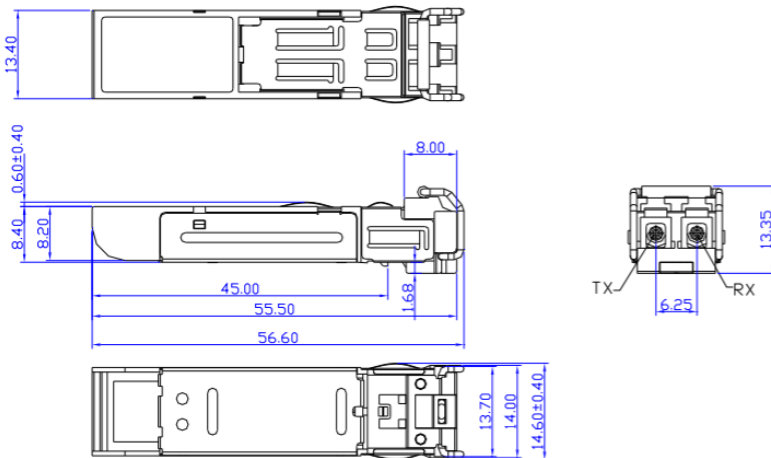

DIMENSIONS ARE IN MILLIMETERS

ALL DIMENSIONS ARE ±0.2mm UNLESS OTHERWISE SPECIFIED

Lasermate Group, Inc.

19608 Camino De Rosa, Walnut, CA 91789, USA

Tel: (909)718-0999 | Fax: (909)718-0998 | E-mail: info@lasermate.com | URL: <http://www.lasermate.com>



SFP HOST BOARD MECHANICAL LAYOUT

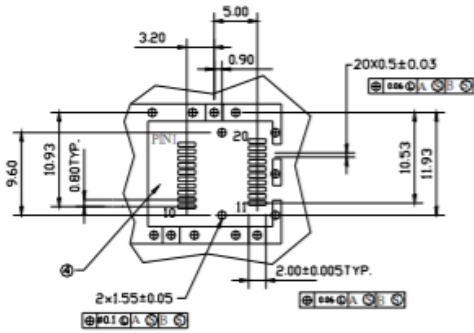
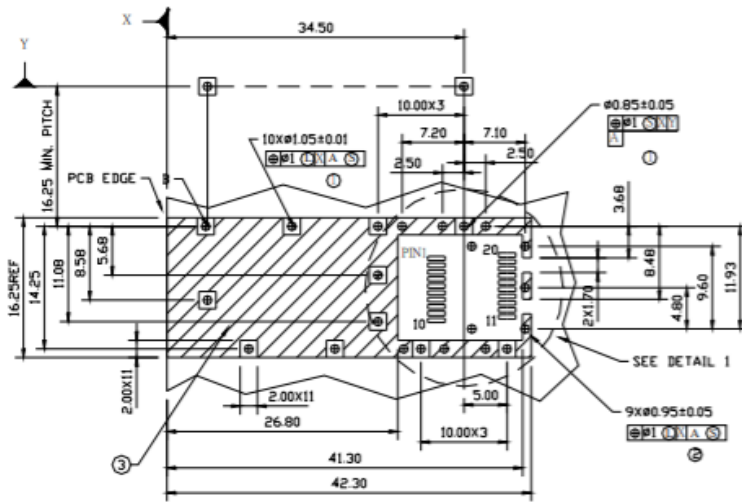

LEGEND

- 1. PADS AND VIAS ARE CHASSIS GROUND
- 2. THROUGH HOLES, PLATING OPTIONAL
- 3. HATCHED AREA DENOTES COMPONENT AND TRACE KEEPOUT (EXCEPT CHASSIS GROUND)
- 4. AREA DENOTES COMPONENT KEEPOUT (TRACES ALLOWED)

DIMENSIONS ARE IN MILLIMETERS

ASSEMBLY DRAWING (unit: mm)



Lasermate Group, Inc.

19608 Camino De Rosa, Walnut, CA 91789, USA

Tel: (909)718-0999 | Fax: (909)718-0998 | E-mail: info@lasermate.com | URL: <http://www.lasermate.com>



PIN ASSIGNMENT



PIN	SIGNAL NAME	DESCRIPTION	PIN	SIGNAL NAME	DESCRIPTION
1	T _{GND}	Transmit Ground	11	R _{GND}	Receiver Ground
2	TX_FAULT	Transmit Fault	12	RX-	Receive Data Bar, Differential PECL, ac coupled
3	TX_DISABLE	Transmit Disable	13	RX+	Receive Data, Differential PECL, ac coupled
4	MOD_DEF (2)	SDA Serial Data Signal	14	R _{GND}	Receiver Ground
5	MOD_DEF (1)	SCL Serial Clock Signal	15	V _{CCR}	Receiver Power Supply
6	MOD_DEF (0)	TTL Low	16	V _{CCT}	Transmitter Power Supply
7	RATE_SELECT	Open Circuit	17	T _{GND}	Transmitter Ground
8	RX_LOS	Receiver Loss of Signal, TTL High, open collector	18	TX+	Transmit Data, Differential PECL, ac coupled
9	R _{GND}	Receiver Ground	19	TX-	Transmit Data Bar, Differential PECL, ac coupled
10	R _{GND}	Receiver Ground	20	T _{GND}	Transmitter Ground

EYE SAFETY MARK

The single-mode transceiver is a class 1 laser product. It complies with EN 60825-1 and FDA 21 CFR 1040.10 and 1040.11. In order to meet laser safety requirements, the transceiver shall be operated within the Absolute Maximum Ratings.

Required Mark

**Class 1 Laser Product
Complies with
21 CFR 1040.10 and 1040.11**

[Caution] All adjustments have been done at the factory before the shipment of the devices. No maintenance and user serviceable part is required. Tampering with and modifying the performance of the device will result in voided product warranty.

ORDERING INFORMATION

PART NUMBER	OPERATING TEMPERATURE
CS13D-12F-3L-TC-LD	0°C to 70°C
CS13D-12F-3L-TI-LD	-40°C to 85°C

Note: The specifications subject to change without notice.

Lasermate Group, Inc.

19608 Camino De Rosa, Walnut, CA 91789, USA

Tel: (909)718-0999 | Fax: (909)718-0998 | E-mail: info@lasermate.com | URL: <http://www.lasermate.com>