



2Mbps 1310nm Single Mode 20km SFP IEEE C37.94 Optical Transceiver with Duplex LC Connector

Model No. CS13-2MF-3C-Tx-L

FEATURES

- IEEE C37.94 application
- RoHS compliant
- Compliant with SFF8472 diagnostic monitoring interface
- Duplex LC connector
- Single power supply 3.3V
- Hot pluggable
- Class 1 laser product compliant with EN 60825-1
- TTL signal detect
- Input/Output: AC/AC

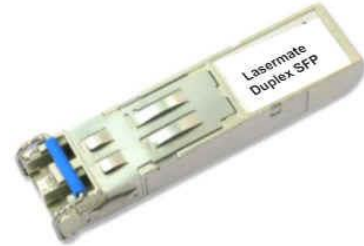

DIAGNOSTICS

PARAMETER	RANGE	ACCURACY	UNIT	CALIBRATION
Temperature	-40 to 85	±3	°C	Internal
Voltage	3.1 to 3.5	±0.1	V	
Bias Current	0 to 60	±10%	mA	
TX Power	-19 to -11	±3db	dBm	
RX Power	-32 to -8	±3db	dBm	

ABSOLUTE MAXIMUM RATINGS

PARAMETER	SYMBOL	MIN	MAX	UNIT	NOTES
Storage Temperature	T _S	-40	85	°C	
Supply Voltage	V _{CC}	-0.5	4.0	V	
Input Voltage	V _{IN}	-0.5	V _{CC}	V	

OPERATING ENVIRONMENT

PARAMETER	SYMBOL	MIN	MAX	UNIT	NOTES
Case Operating Temperature	T _C	0	70	°C	CS13-2MF-3C-TC-L
		-40	85		CS13-2MF-3C-TI-L
Supply Voltage	V _{CC}	3.1	3.5	V	
Supply Current	I _{TX} + I _{RX}	-	250	mA	



TRANSMITTER ELECTRO-OPTICAL CHARACTERISTICS

PARAMETER	SYMBOL	MIN	TYP.	MAX	UNIT	NOTES
Output Optical Power	P _{out}	-19	-	-11	dBm	Average
Extinction Ratio	ER	12	-	-	dB	
Center Wavelength	λ _C	1290	1310	1350	nm	
Max. P _{out} TX-DISABLE Asserted	P _{OFF}	-	-	-45	dBm	
Differential Input Voltage	V _{DIFF}	0.4	-	2.0	V	

RECEIVER ELECTRO-OPTICAL CHARACTERISTICS

PARAMETER	SYMBOL	MIN	TYP.	MAX	UNIT	NOTES
Optical Input Power-Maximum	P _{IN}	-8	-	-	dBm	PRBS7, BER<10 ⁻⁹
Receiver Input Power-Minimum (Sensitivity)	P _{IN}	-	-	-32	dBm	PRBS7, BER<10 ⁻⁹
Operating Center Wavelength	λ _C	1260	-	1360	nm	
LOS-Deasserted	P _A	-	-	-32	dBm	
LOS-Asserted	P _D	-45	-	-	dBm	
Differential Output Voltage	V _{DIFF}	0.6	-	1.8	V	
Receiver Loss of Signal Output Voltage-Low	RX_LOS _L	0	-	0.5	V	
Receiver Loss of Signal Output Voltage-High	RX_LOS _H	2.4	-	V _{CC}	V	

DIMENSIONS

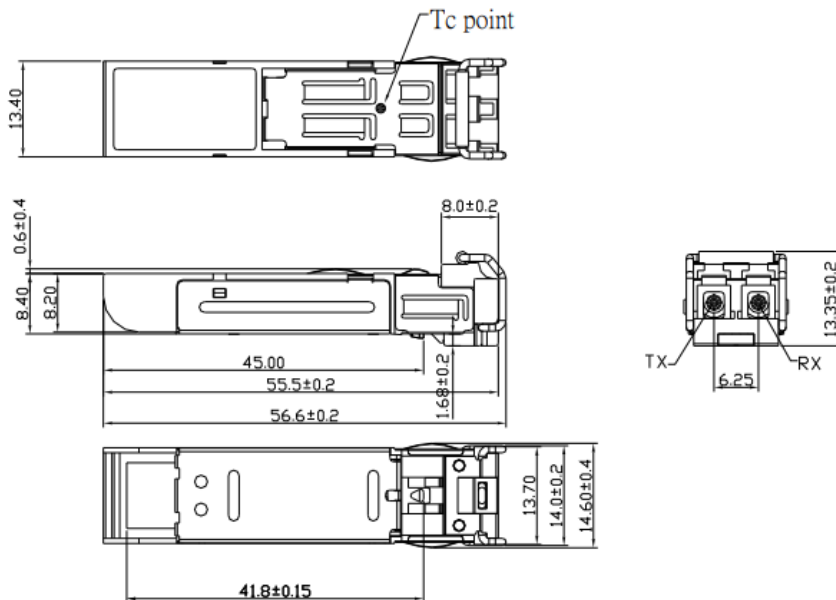

DIMENSIONS ARE IN MILLIMETERS

ALL DIMENSIONS ARE ±0.1mm UNLESS OTHERWISE SPECIFIED

Unit: mm

Lasermate Group, Inc.

19608 Camino De Rosa, Walnut, CA 91789, USA

Tel: (909)718-0999 | Fax: (909)718-0998 | E-mail: info@lasermate.com | URL: <http://www.lasermate.com>



SFP HOST BOARD MECHANICAL LAYOUT

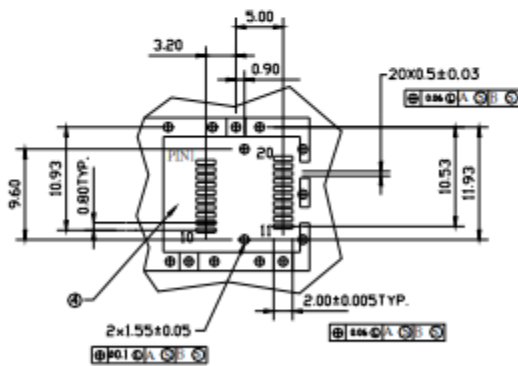
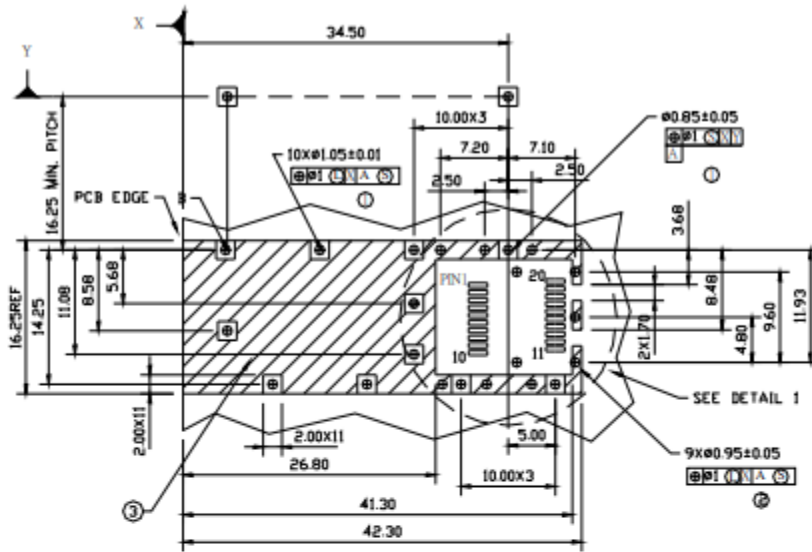

DETAIL 1

LEGEND

1. PADS AND VIAS ARE CHASSIS GROUND
2. THROUGH HOLES, PLATING OPTIONAL
3. HATCHED AREA DENOTES COMPONENT AND TRACE KEEPOUT (EXCEPT CHASSIS GROUND)
4. AREA DENOTES COMPONENT KEEPOUT (TRACES ALLOWED)

DIMENSIONS ARE IN MILLIMETERS

Unit: mm



ASSEMBLY DRAWING

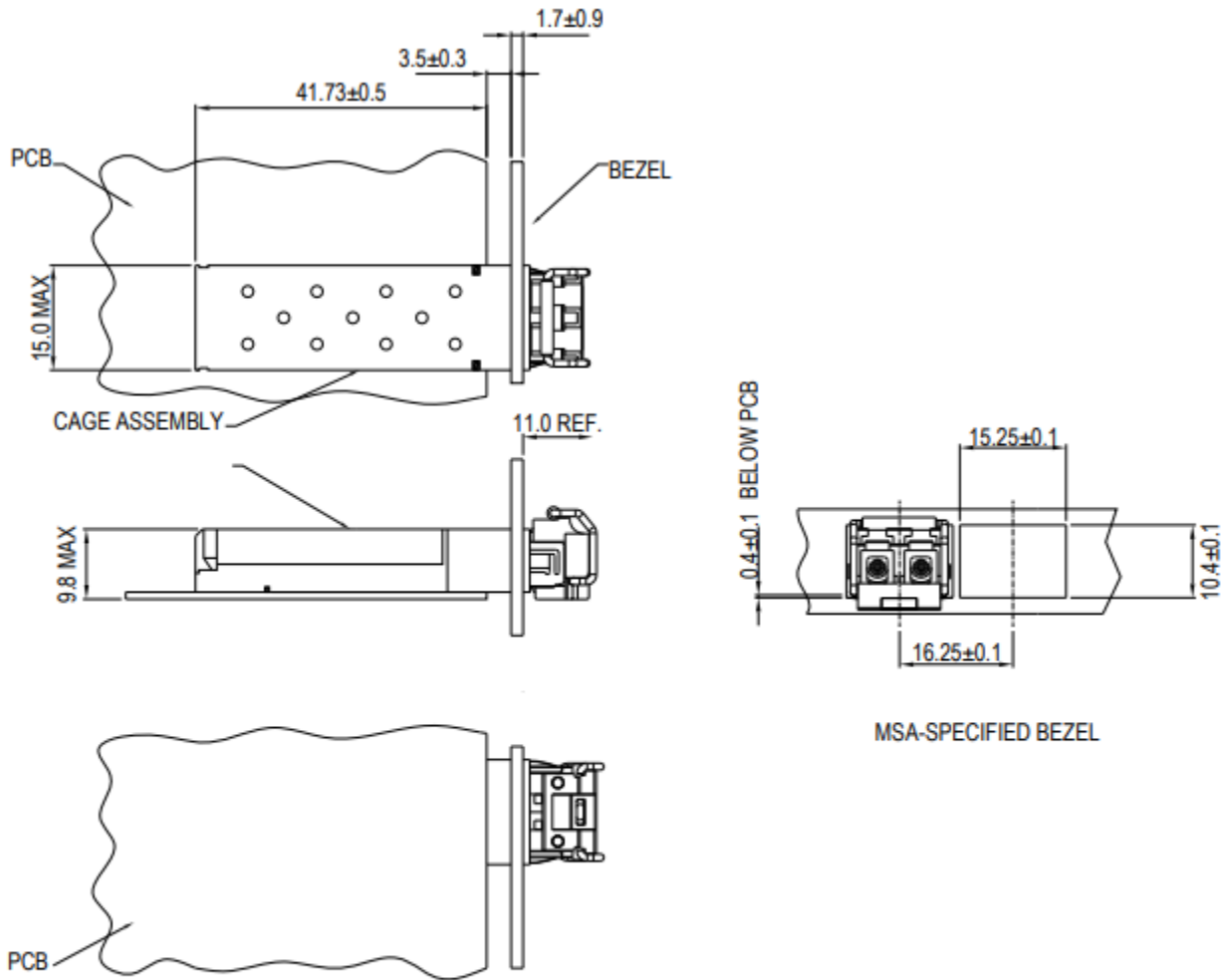

DIMENSIONS ARE IN MILLIMETERS

Unit: mm



PIN ASSIGNMENT

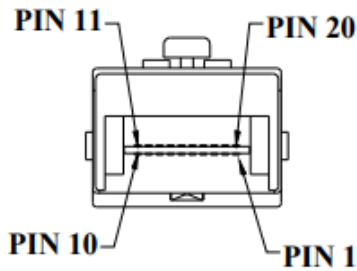

Pin	Signal Name	Description
1	T_{GND}	Transmit Ground
2	TX_FAULT	Transmit Fault
3	$TX_DISABLE$	Transmit Disable
4	$MOD_DEF (2)$	SDA Serial Data Signal
5	$MOD_DEF (1)$	SCL Serial Clock Signal
6	$MOD_DEF (0)$	TTL Low
7	$RATE_SELECT$	Open Circuit
8	RX_LOS	Receiver Loss of Signal, TTL High, open collector
9	R_{GND}	Receiver Ground
10	R_{GND}	Receiver Ground
11	R_{GND}	Receiver Ground
12	$RX-$	Receive Data Bar, Differential , ac coupled
13	$RX+$	Receive Data, Differential , ac coupled
14	R_{GND}	Receiver Ground
15	V_{CCR}	Receiver Power Supply
16	V_{CCT}	Transmitter Power Supply
17	T_{GND}	Transmitter Ground
18	$TX+$	Transmit Data, Differential , ac coupled
19	$TX-$	Transmit Data Bar, Differential , ac coupled
20	T_{GND}	Transmitter Ground

ORDERING INFORMATION

PART NUMBER	OPERATING TEMPERATURE
CS13-2MF-3C-TC-L	0°C to 70°C
CS13-2MF-3C-TI-L	-40°C to 85°C

Note: The specifications subject to change without notice.

Lasermate Group, Inc.

19608 Camino De Rosa, Walnut, CA 91789, USA

Tel: (909)718-0999 | Fax: (909)718-0998 | E-mail: info@lasermate.com | URL: <http://www.lasermate.com>