



25Gbps 850nm MMF 100m SFP28 Optical Transceiver with Duplex LC Connector

Model No. CM85-25GF-3S-Tx-L

FEATURES

- Up to 25.78Gb/s data links
- Hot-pluggable SFP+ footprint
- Compliant with SFP+ MSA SFF-8431
- Compliant with SFF8472 diagnostic monitoring interface
- Duplex LC connector
- 850nm Oxide VCSEL laser transmitter
- RoHS Compliant
- 100m over M5F MMF (50/125um OM4)
- 70m over M5E MMF (50/125um OM3)
- 1W maximum power consumption
- Single power supply 3.3V
- Input/Output: AC/AC



DIAGNOSTICS

PARAMETER	RANGE	ACCURACY	UNIT	CALIBRATION
Internal Transceiver Temperature	-40 to 95	±3	°C	Internal
Internal Transceiver Voltage	3.1 to 3.5	±0.1	V	
Bias Current	0 to 15	±10%	mA	
TX Power	-8.4 to +2.4	±3	dB	
RX Average Power	-10 to +2.4	±3	dB	

ABSOLUTE MAXIMUM RATINGS

PARAMETER	SYMBOL	MIN	MAX	UNIT
Storage Temperature	T _S	-40	85	°C
Supply Voltage	V _{CC}	-0.5	4.0	V
Input Voltage	V _{IN}	-0.5	V _{CC}	V

RECOMMENDED OPERATING CONDITIONS

PARAMETER	SYMBOL	MIN	MAX	UNIT	NOTES
Case Operating Temperature	T _C	0	70	°C	CM85-25GF-3S-TC-L
		-40	85		CM85-25GF-3S-TI-L
Supply Voltage	V _{CC}	3.14	3.46	V	
Supply Current	I _{TX} + I _{RX}		300	mA	
Power Consumption	P	-	1.0	W	

Lasermate Group, Inc.

19608 Camino De Rosa, Walnut, CA 91789, USA

Tel: (909)718-0999 | Fax: (909)718-0998 | E-mail: info@lasermate.com | URL: <http://www.lasermate.com>

**TRANSMITTER ELECTRO-OPTICAL CHARACTERISTICS ($V_{CC} = 3.14V$ to $3.46V$, $T_C = 0^{\circ}C$ to $70^{\circ}C$)**

PARAMETER	SYMBOL	MIN	TYP.	MAX	UNIT
Data Rate	B	25.5	25.78		Gbps
Output Optical Power (50/125um fiber, NA=0.20) (62.5/125um fiber, NA=0.275)	P_{out}	-8.4	-	2.4	dBm
Optical Modulation Amplitude	OMA	-6.4	-1.5	3	dBm
Extinction Ratio	ER	2			dB
Center Wavelength	λ_C	840	850	860	nm
Spectral Width (RMS)	$\Delta\lambda$	-	-	0.6	nm
Transmitter and Dispersion Penalty	TDP			4.3	dB
Max. P_{out} TX-DISABLE Asserted	P_{OFF}	-	-	-35	dBm
Differential Input Impedance	Z_d		100		Ω
Differential Input Voltage Swing	V_{DIFF}	180		700	mV
Transmit Fault Output-Low	TX_FAULT _L	0.0	-	0.8	V
Transmit Fault Output-High	TX_FAULT _H	2.0	-	V_{CC}	V
TX_DISABLE Assert Time	t_{off}	-	-	100	μs
TX_DISABLE Negate Time	t_{on}	-	-	2	ms
Time to Initialize, include reset of TX_FAULT	t_{init}	-	-	300	ms
TX_FAULT from fault to assertion	t_{fault}	-	-	100	μs
TX_DISABLE Time to start reset	t_{reset}	10	-	-	μs

RECEIVER ELECTRO-OPTICAL CHARACTERISTICS ($V_{CC} = 3.14V$ to $3.46V$, $T_C = 0^{\circ}C$ to $70^{\circ}C$)

PARAMETER	SYMBOL	MIN	TYP.	MAX	UNIT	NOTES
Data Rate	B	25.5	25.78		Gbps	
Damage Threshold		3.4	-	-	dBm	
Receiver Overload	P_{IN}	2.4			dBm	BER<5x10 ⁻⁵
Receiver Sensitivity	P_{IN}	-	-	-10.3	dBm	BER<5x10 ⁻⁵
Stressed Receiver Sensitivity (OMA)	P_{IN}	-	-	-5.2	dBm	BER<5x10 ⁻⁵
Operating Center Wavelength	λ_C	840	-	860	nm	
Optical Return Loss	ORL	12	-	-	dB	
Loss of Signal-Asserted	P_A	-30	-	-	dBm	
Loss of Signal-Deasserted	P_D	-	-	-12	dBm	
Differential Output Impedance	Z_d		100		Ω	
Differential Output Voltage	V_{DIFF}	300	-	800	mV	
Receiver Loss of Signal Output Voltage-Low	RX_LOS _L	0	-	0.8	V	
Receiver Loss of Signal Output-High	RX_LOS _H	2.0	-	V_{CC}	V	
Receiver Loss of Signal Assert Time (off to on)	t_{A,RX_LOS}	-	-	100	μs	
Receiver Loss of Signal Assert Time (on to off)	t_{D,RX_LOS}	-	-	100	μs	



DIGITAL DIAGNOSTIC MEMORY MAP

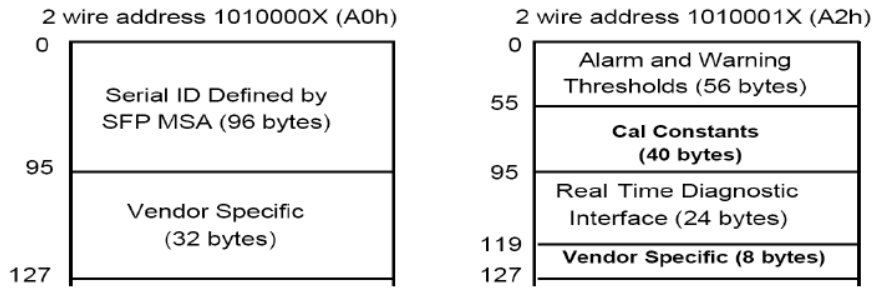

EEPROM Serial ID Memory Contents (A0h)

Address	Hex	Fields	Result
0	03(H)	identifier	SFP or SFP+ or SFP28
1	04(H)	Ext.Identifier	GBIC/SFP function is defined by two-wire interface ID only
2	07(H)	Connector	LC
3	00(H)	Transceiver	Unallocated
4	00(H)		
5	00(H)		
6	00(H)		
7	00(H)		
8	00(H)		
9	04(H)	Transceiver	Multimode;50um(M5;M5E);
10	00(H)	Transceiver	Unallocated
11	06(H)	Encoding	64B/66B
12	FF(H)	BR(Nominal)	25500Mbps
13	00(H)	Rate Identifier	Unspecified
14	00(H)	Length(SMFm)-km	N/A
15	00(H)	Length(SMF)	N/A
16	00(H)	Length(50µm)	N/A
17	00(H)	Length(62.5µm)	N/A
18	0A(H)	Length (50um, OM4)	10(units of 10m)
19	07(H)	Length(OM3)	7(units of 10m)
20	41(H)	Vendor name	A
21	50(H)	Vendor name	P
22	41(H)	Vendor name	A
23	43(H)	Vendor name	C
24	20(H)	Vendor name	
25	4F(H)	Vendor name	O



26	70(H)	Vendor name	p
27	74(H)	Vendor name	t
28	6F(H)	Vendor name	o
29	20(H)	Vendor name	
30	20(H)	Vendor name	
31	20(H)	Vendor name	
32	20(H)	Vendor name	
33	20(H)	Vendor name	
34	20(H)	Vendor name	
35	20(H)	Vendor name	
36	00(H)	Transceiver	Unallocated
37	00(H)	Vendor OUI	0
38	0F(H)	Vendor OUI	0F
39	99(H)	Vendor OUI	99
40	4C(H)	Vendor PN	L
41	45(H)	Vendor PN	E
42	32(H)	Vendor PN	2
43	38(H)	Vendor PN	8
44	2D(H)	Vendor PN	-
45	4A(H)	Vendor PN	J
46	33(H)	Vendor PN	3
47	53(H)	Vendor PN	S
48	2D(H)	Vendor PN	-
49	54(H)	Vendor PN	T
50	43(H)	Vendor PN	C
51	2D(H)	Vendor PN	-
52	4E(H)	Vendor PN	N
53	20(H)	Vendor PN	
54	20(H)	Vendor PN	
55	20(H)	Vendor PN	
56	30(H)	Vendor rev	0
57	30(H)	Vendor rev	0
58	30(H)	Vendor rev	0
59	30(H)	Vendor rev	0
60	03(H)	Wavelength	850nm
61	52(H)	Wavelength	
62	00(H)	Unallocated	Unallocated
63		CC_BASE	
64	08(H)	Options	Retimer or CDR indicator;
65	1A(H)	Options	Loss of Signal;Tx_Fault;Tx_Disable;
66	67(H)	BR(Nominal)	25750M
67	02(H)	BR(Limit Range)	±2%
68	49(H)	Vendor SN	I



69	34(H)		4
70	32(H)		2
71	36(H)		6
72	32(H)		2
73	32(H)		2
74	39(H)		9
75	30(H)		0
76	30(H)		0
77	31(H)		1
78	20(H)		
79	20(H)		
80	20(H)		
81	20(H)		
82	20(H)		
83	20(H)		
84	31(H)	Date code	1
85	38(H)		8
86	30(H)		0
87	34(H)		4
88	32(H)		2
89	36(H)		6
90	20(H)		
91	20(H)		
92	68(H)	Diagnostic Monitoring Type	Received Average Power Measurement Type; Internally Calibrated; Digital diagnostic monitoring implemented;
93	F0(H)	Enhanced Options	Rx_Loss Monitoring; Tx_Fault Monitoring; Tx_Disable Contorl; Alarm/warning Flags;
94	08(H)	SFF-8472 Compliance	includes functionality described in Rev 12.0 of SFF-8472
95		CC_EXT	
96	45(H)	Vendor Specific	E
97	58(H)	Vendor Specific	X
98	54(H)	Vendor Specific	T
99	52(H)	Vendor Specific	R
100	45(H)	Vendor Specific	E
101	4D(H)	Vendor Specific	M
102	45(H)	Vendor Specific	E
103	4C(H)	Vendor Specific	L
104	59(H)	Vendor Specific	Y
105	20(H)	Vendor Specific	
106	43(H)	Vendor Specific	C
107	4F(H)	Vendor Specific	O
108	4D(H)	Vendor Specific	M
109	50(H)	Vendor Specific	P

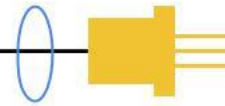

110	41(H)	Vendor Specific	A
111	54(H)	Vendor Specific	T
112	49(H)	Vendor Specific	I
113	42(H)	Vendor Specific	B
114	4C(H)	Vendor Specific	L
115	45(H)	Vendor Specific	E
116	20(H)	Vendor Specific	
117	20(H)	Vendor Specific	
118	20(H)	Vendor Specific	
119	20(H)	Vendor Specific	
120	20(H)	Vendor Specific	
121	20(H)	Vendor Specific	
122	20(H)	Vendor Specific	
123	20(H)	Vendor Specific	
124	20(H)	Vendor Specific	
125	20(H)	Vendor Specific	
126	20(H)	Vendor Specific	
127	20(H)	Vendor Specific	



EEPROM Serial ID Memory Contents (A2h)

For $T_c = 0^\circ\text{C}$ to 70°C

Address(A2h)	Description	Value
00-01	Temp High Alarm	75 Degree C
02-03	Temp Low Alarm	-5 Degree C
04-05	Temp High Warning	70 Degree C
06-07	Temp Low Warning	0 Degree C
08-09	Voltage High Alarm	3.6 V
10-11	Voltage Low Alarm	3.0 V
12-13	Voltage High Warning	3.5 V
14-15	Voltage Low Warning	3.1 V
16-17	Bias High Alarm	10 mA
18-19	Bias Low Alarm	0.1 mA
20-21	Bias High Warning	9 mA
22-23	Bias Low Warning	0.5 mA
24-25	TX Power High Alarm	3.4 dBm
26-27	TX Power Low Alarm	-9.4 dBm
28-29	TX Power High Warning	2.4 dBm
30-31	TX Power Low Warning	-8.4 dBm
32-33	RX Power High Alarm	3.4 dBm
34-35	RX Power Low Alarm	-12 dBm
36-37	RX Power High Warning	2.4 dBm
38-39	RX Power Low Warning	-10 dBm
40-55	Reserved Reserved for future monitored quantities	
56-91	External calibration constant	
92-94	Reserved	
95	Check sum	
96-97	Real Time temperature	
98-99	Real Time supply voltage	
100-101	Real Time TX bias current	
102-103	Real Time TX optical power	
104-105	Real Time RX received power	
106-109	Reserved	
110(bit7)	TX Disable State	
110(bit6)	Soft TX Disable	
110(bit5)	Hard RS(1) State	
110(bit4)	Hard RS(0) State	
110(bit3)	Soft RS(0) Select	
110(bit2)	Digital state of TX fault output pin	
110(bit1)	Digital state of LOS output pin	
110(bit0)	Data Ready Bar State	



111	Reserved	
112(bit7)	Set when internal temperature exceeds high alarm level	
112(bit6)	Set when internal temperature exceeds is below alarm level	
112(bit5)	Set when internal supply voltage exceeds high alarm level	
112(bit4)	Set when internal supply voltage is below alarm level	
112(bit3)	Set when TX bias exceeds high alarm level	
112(bit2)	Set when TX bias voltage is below alarm level	
112(bit1)	Set when TX output power exceeds high alarm level	
112(bit0)	Set when TX output power voltage is below alarm level	
113(bit7)	Set when RX received power exceeds high alarm level	
113(bit6)	Set when RX received power is below alarm level	
113(bit5-0)	Reserved	
114(bit7-0)	INPUT EQUALIZATION (bit7~4 for RS1= H; bit 3~ 0 for RS1= L)	
115(bit 7-0)	OUTPUT EMPHASIS CONTROL (bit7~4 for RS0= H; bit 3~ 0 for RS0=L)	
116(bit7)	Set when internal temperature exceeds high warning level	
116(bit6)	Set when internal temperature exceeds is below warning level	
116(bit5)	Set when internal supply voltage exceeds high warning level	
116(bit4)	Set when internal supply voltage is below warning level	
116(bit3)	Set when TX bias exceeds high warning level	
116(bit2)	Set when TX bias voltage is below warning level	
116(bit1)	Set when TX output power exceeds high warning level	
116(bit0)	Set when TX output power voltage is below warning level	
117(bit7)	Set when RX received power exceeds high warning level	
117(bit6)	Set when RX received power is below warning level	
117(bit5-0)	Reserved	
118(bit7-4)	Reserved	
118(bit3)	Soft RS(1) Select	
118(bit2)	Reserved	
118(bit1)	Power Level Operation State (not complement)	
118(bit0)	Power Level Select (not complement)	
119(bit7-2)	Reserved	
119(bit1)	Tx CDR state (1 for lock, 0 for unlock)	
119(bit0)	Rx CDR state (1 for lock, 0 for unlock)	
120-127	Reserved	



RECOMMENDED INTERFACE CIRCUIT (Part 1)

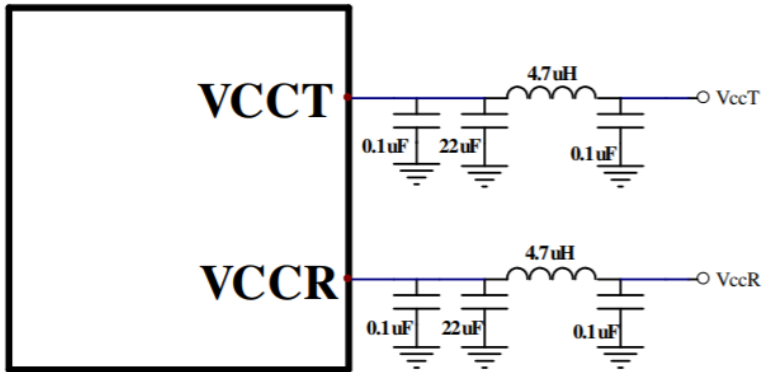

SFP28 module

RECOMMENDED INTERFACE CIRCUIT (Part 2)

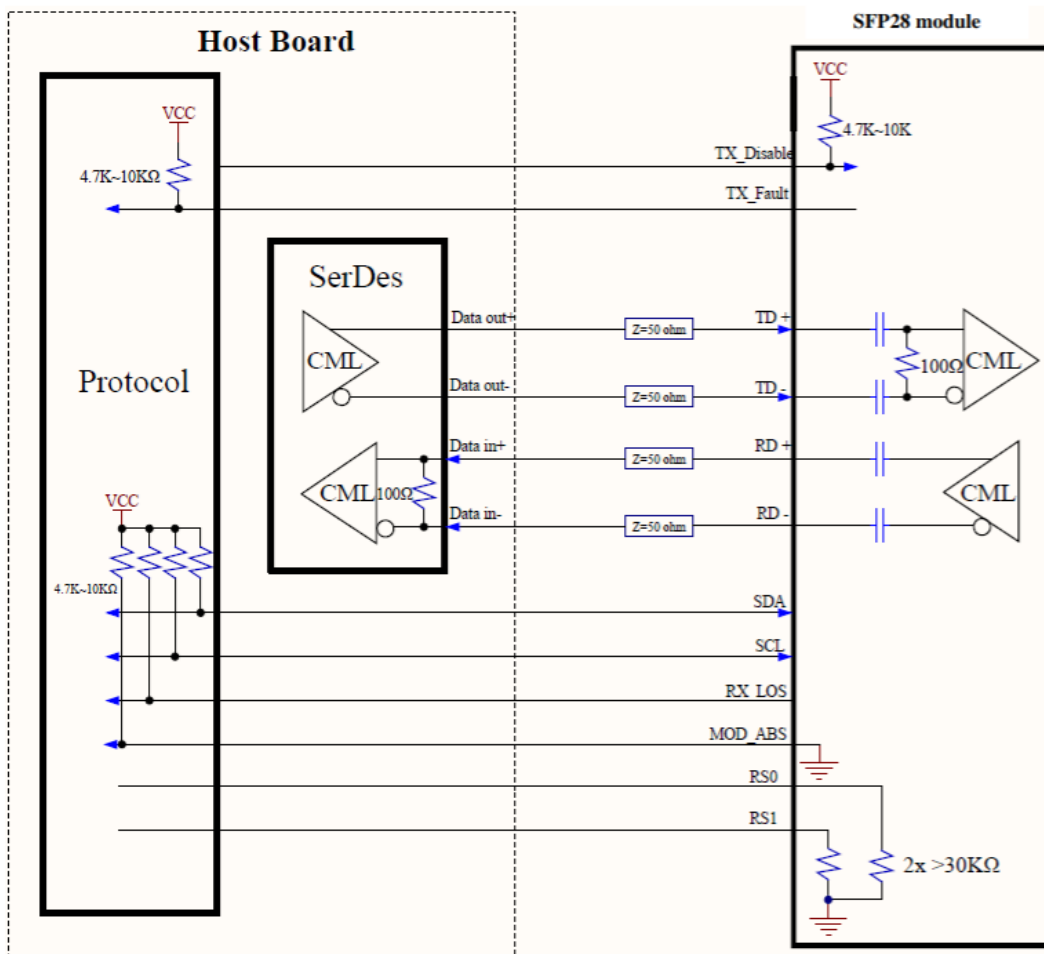



SFP HOST BOARD MECHANICAL LAYOUT

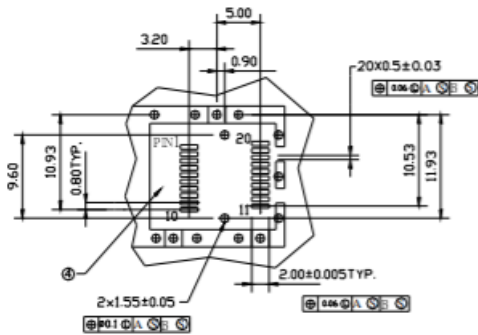
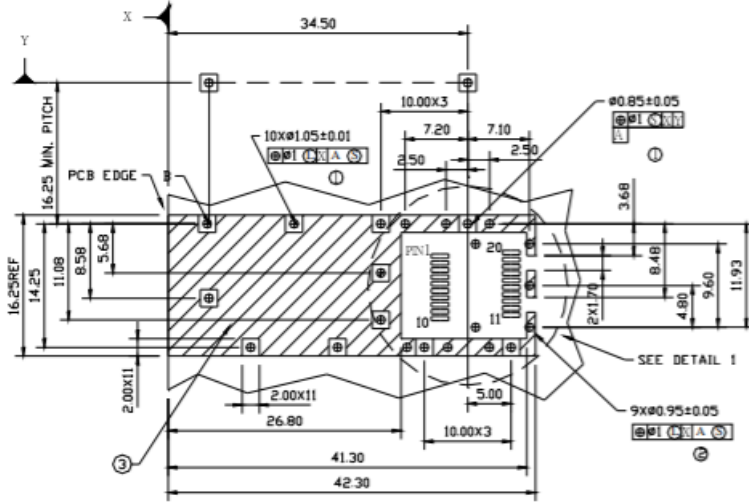

DETAIL 1

LEGEND

- 1. PADS AND VIAS ARE CHASSIS GROUND
- 2. THROUGH HOLES, PLATING OPTIONAL
- 3. HATCHED AREA DENOTES COMPONENT AND TRACE KEEPOUT (EXCEPT CHASSIS GROUND)
- 4. AREA DENOTES COMPONENT KEEPOUT (TRACES ALLOWED)

DIMENSIONS ARE IN MILLIMETERS

Unit: mm

DIMENSIONS (unit: mm)

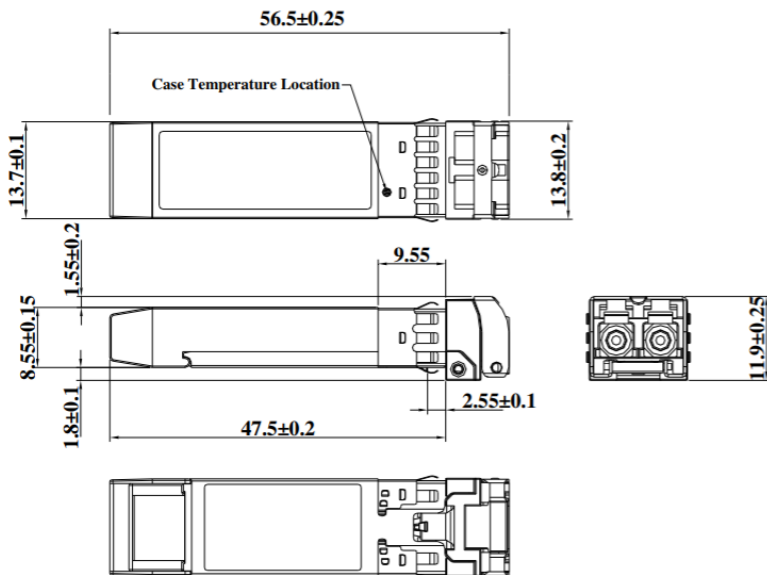



ASSEMBLY DRAWING

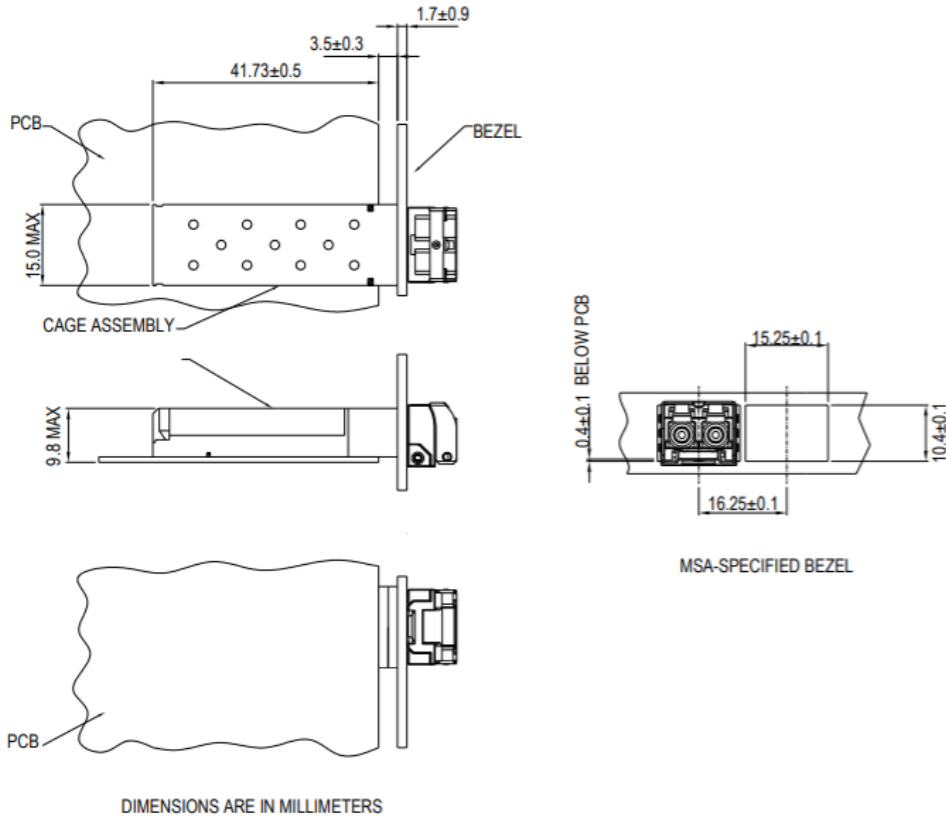

PIN ASSIGNMENT

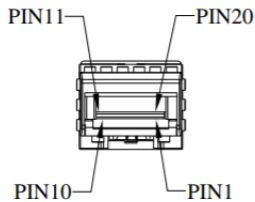

PIN	SIGNAL NAME	DESCRIPTION	PIN	SIGNAL NAME	DESCRIPTION
1	T _{GND}	Transmit Ground	11	R _{GND}	Receiver Ground
2	TX_FAULT	Transmit Fault	12	RX-	Receive Data out Bar, ac coupled
3	TX_DISABLE	Transmit Disable	13	RX+	Receive Data out, ac coupled
4	MOD_DEF (2)	SDA Serial Data Signal	14	R _{GND}	Receiver Ground
5	MOD_DEF (1)	SCL Serial Clock Signal	15	V _{CCR}	Receiver Power Supply
6	MOD_DEF (0)	LVTTTL Low	16	V _{CCT}	Transmitter Power Supply
7	RS0	RX Rate Select, No used	17	T _{GND}	Transmitter Ground
8	RX_LOS	Receiver Loss of Signal, LVTTTL High, open drain	18	TX+	Transmit Data in, ac coupled
9	RS1	TX Rate Select, No used	19	TX-	Transmit Data in Bar, ac coupled
10	R _{GND}	Receiver Ground	20	T _{GND}	Transmitter Ground



ORDERING INFORMATION

PART NUMBER	OPERATING TEMPERATURE
CM85-25GF-3S-TC-L	0°C to 70°C
CM85-25GF-3S-TI-L	-40°C to 85°C

Note: The specifications subject to change without notice.