



## 10GBASE-SW/SR 10G Ethernet 850nm MMF Mini SFF Optical Transceiver

Part No. CM85-10GM-3S-TI

### Features

- Single power supply 3.3V
- Duplex LC optical connection
- Class 1 laser product compliant with EN 60825-1
- Input/Output: AC/AC
- Temperature: -40°C to 85°C
- Transmit distance: 33m (OM1 Fiber), 82m (OM2 Fiber), 300m (OM3 Fiber), 400m (OM4 Fiber)



### Diagnostics

PARAMETER	RANGE	ACCURACY	UNIT	CALIBRATION
Internal Transceiver Temperature	-40 to 95	±3	°C	Internal
Internal Transceiver Voltage	3.0 to 3.6	±0.1	V	
Bias Current	0 to 15	±10%	mA	
TX Power	-8 to 0	±3	dB	
RX Average Power	-14 to 0	±3	dB	

### Absolute Maximum Ratings

PARAMETER	SYMBOL	MIN	MAX	UNIT
Storage Temperature	T <sub>s</sub>	-40	85	°C
Supply Voltage	V <sub>CC</sub>	-0.5	4.0	V
Input Voltage	V <sub>IN</sub>	-0.5	V <sub>CC</sub>	V

### Recommended Operating Conditions

PARAMETER	SYMBOL	MIN	MAX	UNIT
Case Operating Temperature	T <sub>c</sub>	-40	85	°C
Supply Voltage	V <sub>CC</sub>	3.14	3.46	V
Supply Current	I <sub>TX</sub> + I <sub>RX</sub>		300	mA
Power Consumption	P	-	1.0	W

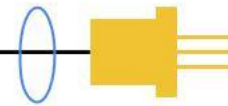

**Transmitter Electro-Optical Characteristics ( $V_{CC} = 3.14V$  to  $3.46V$ ,  $T_C = -40^{\circ}C$  to  $85^{\circ}C$ )**

PARAMETER	SYMBOL	MIN	TYP.	MAX	UNIT
Data Rate	B		10.3125		Gbps
Output Optical Power (50/125um fiber, NA=0.20) (62.5/125um fiber, NA=0.275)	$P_{out}$	-7.1	-	-1	dBm
Optical Modulation Amplitude	OMA	-4.3			dBm
Extinction Ratio	ER	3.5			dB
Center Wavelength	$\lambda_c$	840	850	860	nm
Spectral Width (RMS)	$\Delta\lambda$	-	-	0.45	nm
Transmitter and Dispersion Penalty	TDP			3.9	dB
Relative Intensity Noise	RIN	-	-	-128	dB/Hz
Output Eye		Compliant with IEEE802.3ae			
Max. $P_{out}$ TX-DISABLE Asserted	$P_{OFF}$	-	-	-35	dBm
Differential Input Impedance	$Z_d$	80	100	120	$\Omega$
Differential Input Voltage Swing	$V_{DIFF}$	200		800	mV
TX_DISABLE Assert Time	$t_{off}$	-	-	100	$\mu s$
TX_DISABLE Negate Time	$t_{on}$	-	-	2	ms
Time to Initialize	$t_{init}$	-	-	300	ms
TX_DISABLE Time to start reset	$t_{reset}$	10	-	-	$\mu s$

**Receiver Electro-Optical Characteristics ( $V_{CC} = 3.14V$  to  $3.46V$ ,  $T_C = -40^{\circ}C$  to  $85^{\circ}C$ )**

PARAMETER	SYMBOL	MIN	TYP.	MAX	UNIT	NOTES
Data Rate	B		10.3125		Gbps	
Optical Input Power-Maximum	$P_{IN}$	-1	-	-	dBm	BER<10 <sup>-12</sup>
Receiver Sensitivity (OMA)	$P_{IN}$	-	-	-11.1	dBm	BER<10 <sup>-12</sup>
Operating Center Wavelength	$\lambda_c$	840	-	860	nm	
Optical Return Loss	ORL	12	-	-	dB	
Loss of Signal-Asserted	$P_A$	-30	-	-	dBm	Note 1
Loss of Signal-Deasserted	$P_D$	-	-	-12	dBm	Note 1
Differential Output Impedance	$Z_d$	80	100	120	$\Omega$	
Differential Output Voltage	$V_{DIFF}$	300	-	800	mV	

Note:

1. The LOS state is monitored and defined at SFF-8472 byte 110 bit 1.

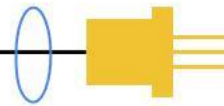

### Digital Diagnostic Memory Map

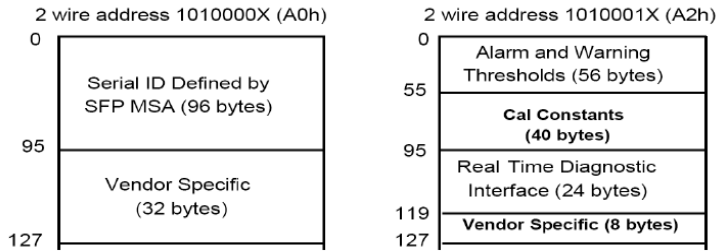

### EEPROM Serial ID Memory Contents (A0h)

Address	Hex	Fields	Result
0	02(H)	identifier	Module soldered to motherboard
1	04(H)	Ext.Identifier	GBIC/SFP function is defined by two-wire interface ID only
2	07(H)	Connector	LC
3	10(H)	Transceiver	10G Base-SR;
4	00(H)	Transceiver	Unallocated
5	00(H)		
6	00(H)		
7	00(H)		
8	00(H)		
9	0C(H)	Transceiver	Multimode;50um(M5;M5E); Multimode; 62.5 um(M6);
10	80(H)	Transceiver	1200MBytes/sec;
11	06(H)	Encoding	64B/66B
12	67(H)	BR(Nominal)	10300Mbps
13	00(H)	Rate Identifier	Unspecified
14	00(H)	Length(SMF)-km	NA
15	00(H)	Length(SMF)	NA
16	08(H)	Length(50um)	8(units of 10m)
17	03(H)	Length(62.5um)	3(units of 10m)
18	00(H)	Length(cable)	NA
19	1E(H)	Length(OM3)	30(units of 10m)
20	41(H)	Vendor name	A
21	50(H)	Vendor name	P
22	41(H)	Vendor name	A
23	43(H)	Vendor name	C
24	20(H)	Vendor name	
25	4F(H)	Vendor name	O
26	70(H)	Vendor name	p

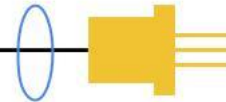

27	74(H)	Vendor name	t
28	6F(H)	Vendor name	o
29	20(H)	Vendor name	
30	20(H)	Vendor name	
31	20(H)	Vendor name	
32	20(H)	Vendor name	
33	20(H)	Vendor name	
34	20(H)	Vendor name	
35	20(H)	Vendor name	
36	00(H)	Transceiver	Unallocated
37	00(H)	Vendor OUI	0
38	0F(H)	Vendor OUI	0F
39	99(H)	Vendor OUI	99
40	4C(H)	Vendor PN	L
41	4D(H)	Vendor PN	M
42	32(H)	Vendor PN	2
43	34(H)	Vendor PN	4
44	2D(H)	Vendor PN	-
45	48(H)	Vendor PN	H
46	33(H)	Vendor PN	3
47	53(H)	Vendor PN	S
48	2D(H)	Vendor PN	-
49	54(H)	Vendor PN	T
50	49(H)	Vendor PN	I
51	2D(H)	Vendor PN	-
52	4E(H)	Vendor PN	N
53	20(H)	Vendor PN	
54	20(H)	Vendor PN	
55	20(H)	Vendor PN	
56	30(H)	Vendor rev	0
57	30(H)	Vendor rev	0
58	30(H)	Vendor rev	0
59	30(H)	Vendor rev	0
60	03(H)	Wavelength	850nm
61	52(H)	Wavelength	
62	00(H)	Unallocated	Unallocated
63		CC_BASE	
64	00(H)	Options	Unallocated
65	10(H)	Options	Tx_Disable;
66	00(H)	BR	max
67	00(H)	BR	min
68		Vendor SN	
69			
70			

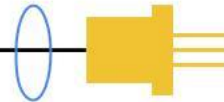

71			
72			
73			
74			
75			
76			
77			
78			
79			
80			
81			
82			
83			
84		Date code	
85			
86			
87			
88			
89			
90			
91			
92	68(H)	Diagnostic Monitoring Type	Received Power Measurement Type; Internally Calibrated; Digital diagnostic monitoring implemented;
93	F0(H)	Enhanced Options	Alarm/warning Flags; TX_DISABLE control and monitoring; TX_FAULT monitoring; RX_LOS monitoring
94	03(H)	SFF-8472 Compliance	includes functionality described in Rev 10.2 of SFF-8472
95		CC_EXT	
96	45(H)	Vendor Specific	E
97	58(H)	Vendor Specific	X
98	54(H)	Vendor Specific	T
99	52(H)	Vendor Specific	R
100	45(H)	Vendor Specific	E
101	4D(H)	Vendor Specific	M
102	45(H)	Vendor Specific	E
103	4C(H)	Vendor Specific	L
104	59(H)	Vendor Specific	Y
105	20(H)	Vendor Specific	
106	43(H)	Vendor Specific	C
107	4F(H)	Vendor Specific	O
108	4D(H)	Vendor Specific	M

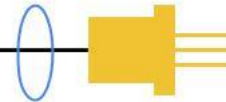

109	50(H)	Vendor Specific	P
110	41(H)	Vendor Specific	A
111	54(H)	Vendor Specific	T
112	49(H)	Vendor Specific	I
113	42(H)	Vendor Specific	B
114	4C(H)	Vendor Specific	L
115	45(H)	Vendor Specific	E
116	20(H)	Vendor Specific	
117	20(H)	Vendor Specific	
118	20(H)	Vendor Specific	
119	20(H)	Vendor Specific	
120	20(H)	Vendor Specific	
121	20(H)	Vendor Specific	
122	20(H)	Vendor Specific	
123	20(H)	Vendor Specific	
124	20(H)	Vendor Specific	
125	20(H)	Vendor Specific	
126	20(H)	Vendor Specific	
127	20(H)	Vendor Specific	

**EEPROM Serial ID Memory Contents (A2h)**

Address (A2h)	Description	Value
00-01	Temp High Alarm	90 Degree C
02-03	Temp Low Alarm	-45 Degree C
04-05	Temp High Warning	85 Degree C
06-07	Temp Low Warning	-40 Degree C
08-09	Voltage High Alarm	3.6 V
10-11	Voltage Low Alarm	3.0 V
12-13	Voltage High Warning	3.5 V
14-15	Voltage Low Warning	3.1 V
16-17	Bias High Alarm	10 mA
18-19	Bias Low Alarm	0.1 mA
20-21	Bias High Warning	9 mA
22-23	Bias Low Warning	0.5 mA
24-25	TX Power High Alarm	0 dBm
26-27	TX Power Low Alarm	-8.1 dBm
28-29	TX Power High Warning	-1 dBm
30-31	TX Power Low Warning	-7.1 dBm
32-33	RX Power High Alarm	0 dBm
34-35	RX Power Low Alarm	-14 dBm
36-37	RX Power High Warning	-1 dBm
38-39	RX Power Low Warning	-12 dBm
40-55	Reserved Reserved for future monitored quantities	
56-91	External calibration constant	

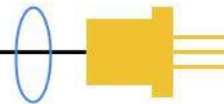

92-94	Reserved	
95	Check sum	
96-97	Real Time temperature	
98-99	Real Time supply voltage	
100-101	Real Time TX bias current	
102-103	Real Time TX optical power	
104-105	Real Time RX received power	
106-109	Reserved	
110(bit7)	NA	
110(bit6)	NA	
110(bit5)	Reserved	
110(bit4)	NA	
110(bit3)	NA	
110(bit2)	Digital state of TX fault output pin	
110(bit1)	Digital state of LOS output pin	
110(bit0)	NA	
111	Reserved	
112(bit7)	Set when internal temperature exceeds high alarm level	
112(bit6)	Set when internal temperature exceeds is below alarm level	
112(bit5)	Set when internal supply voltage exceeds high alarm level	
112(bit4)	Set when internal supply voltage is below alarm level	
112(bit3)	Set when TX bias exceeds high alarm level	
112(bit2)	Set when TX bias voltage is below alarm level	
112(bit1)	Set when TX output power exceeds high alarm level	
112(bit0)	Set when TX output power voltage is below alarm level	
113(bit7)	Set when RX received power exceeds high alarm level	
113(bit6)	Set when RX received power is below alarm level	
113(bit5-0)	Reserved	
114-115	Reserved	
116(bit7)	Set when internal temperature exceeds high warning level	
116(bit6)	Set when internal temperature exceeds is below warning level	
116(bit5)	Set when internal supply voltage exceeds high warning level	
116(bit4)	Set when internal supply voltage is below warning level	
116(bit3)	Set when TX bias exceeds high warning level	
116(bit2)	Set when TX bias voltage is below warning level	
116(bit1)	Set when TX output power exceeds high warning level	
116(bit0)	Set when TX output power voltage is below warning level	
117(bit7)	Set when RX received power exceeds high warning level	
117(bit6)	Set when RX received power is below warning level	
117(bit5-0)	Reserved	
118-119	Reserved	
120-127	Reserved	

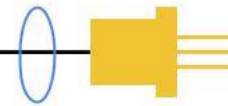

**Recommended Interface Circuit**

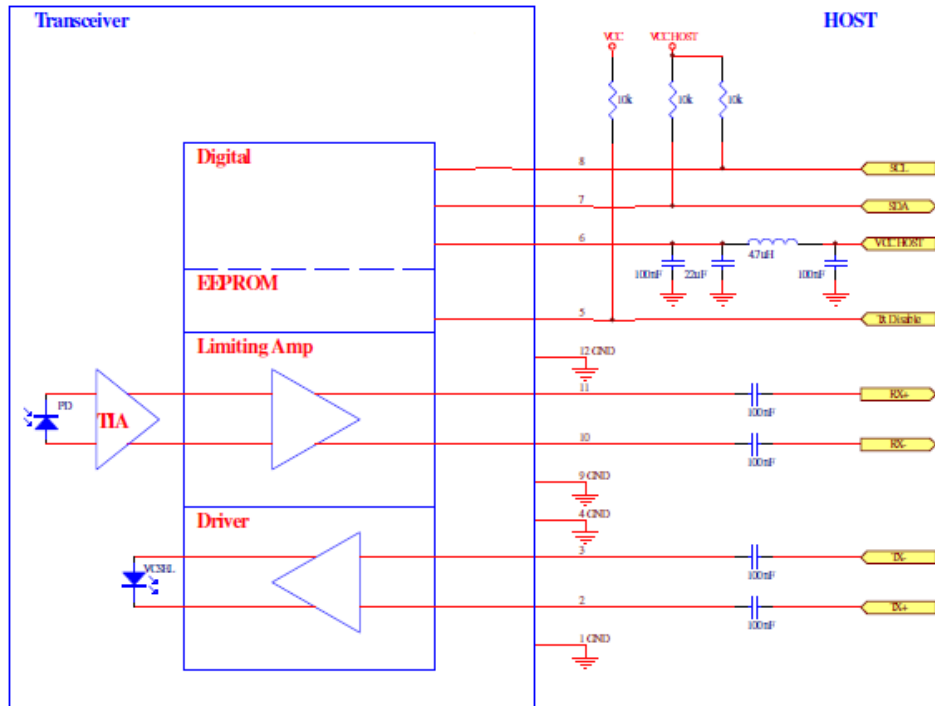

**Recommended Host Board Mechanical Layout**

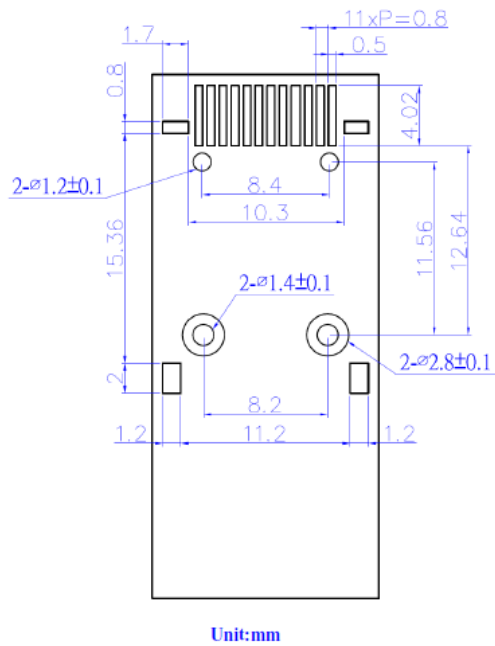



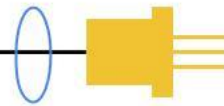

## Dimensions

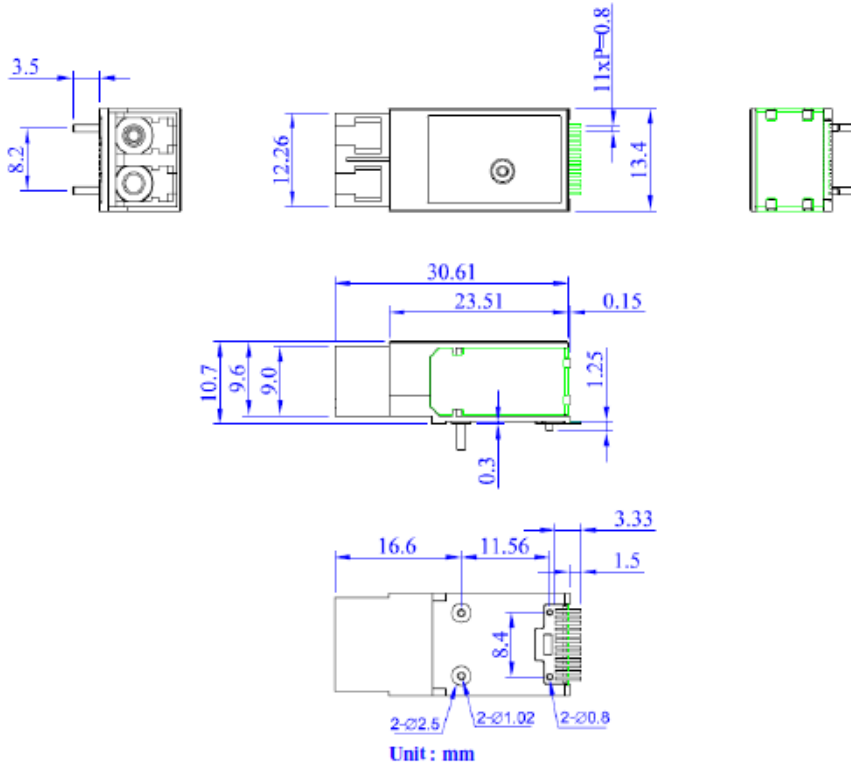

## Pin Assignment

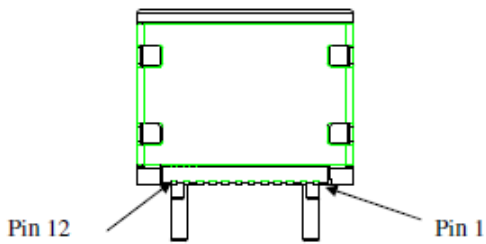

PIN	SIGNAL NAME	DESCRIPTION
1	GND	Ground
2	TX+	Transmit Data in, ac coupled
3	TX-	Transmit Data in Bar, ac coupled
4	GND	Ground
5	TX_DISABLE	Transmit Disable
6	V <sub>cc</sub>	3.3V Power Supply
7	MOD_DEF (2)	SDA Serial Data Signal
8	MOD_DEF (1)	SCL Serial Clock Signal
9	GND	Ground
10	RX-	Receive Data out Bar, ac coupled
11	RX+	Receive Data out, ac coupled
12	GND	Ground

Note: Specifications are subject to change without notice.