

2.5Gbps 1260-1620nm APD plus AGC Pre-amplifier in TO-46 Package

Part No. APD-A13P5-2GA3

Features

- 1310nm/1550nm continuous mode APDTIA TO
- Industry standard TO-46 package with short cap lens and tab-less
- Gigabit-Capable Passive Optical Networks (GPON) application
- Design for long wavelength 2.5Gbps applications
- Supports +3.3V application

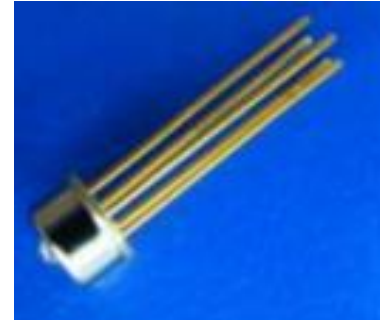

Specifications

Absolute Maximum Ratings				
Parameters	Min.	Max.	Unit	Conditions
Storage temperature	-40	100	°C	
Operating temperature	-40	85	°C	
Lead solder temperature		260	°C	10 seconds

Electro-Optical Characteristics (Typical values are at + 3.3V@25°C)						
Parameters	Symbol	Min.	Typ.	Max.	Unit	Conditions
Power supply	V _{CC}	3.0	3.3	3.6	V	
Supply current	I _{CC}	15	20	24	mA	No loads
APDTIA breakdown voltage	V _{BR}	40		55	V	I _d =10uA, T _A =25°C
Operating voltage	V _{OP}		V _{BR} -3		V	V _{CC} =3.3V
V _{BR} temperature coefficient	γ		0.1		V/°C	
Differential responsivity	R _d	30	48	76	mV/uW	λ=1490nm, R _{load} =100ohm, M=9, P= -30dBm, T _A =25°C, V _{OP} =V _{BR} -2V
Single ended responsivity	R _s	15	24	38	mV/uW	λ=1490nm, R _{load} =50ohm, M=9, P=-30dBm, T _A =25°C, V _{OP} =V _{BR} -2V
Small-signal bandwidth	BW	1.4			GHz	
Low frequency cut off	LF		30		kHz	
Saturation power	P _{sat}	-7			dBm	λ=1490nm, @2488.32Mbps
Single ended output impedance	R _O		50		ohm	
Wavelength	λ	1260		1620	nm	
Sensitivity				-31	dBm	λ=1490nm, @2488.32Mbps, PRBS23, ER=10dB, BER=10 ⁻¹⁰

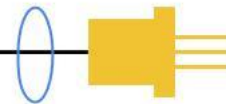

Typical Characteristics

Eye Diagram

R_{load} = 50ohm, P = -30dBm@2488.32Mbps, 1490nm, PRBS 23

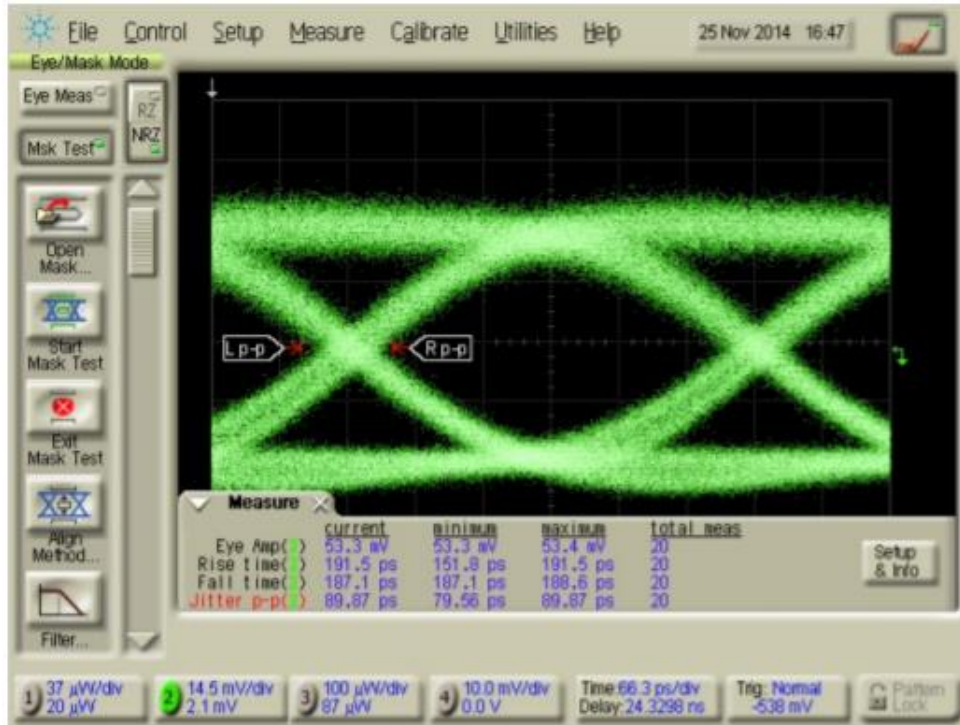

tr=191.5ps, tf=187.1ps, Jitter p-p=89.87ps

Outline Dimensions (unit: mm)

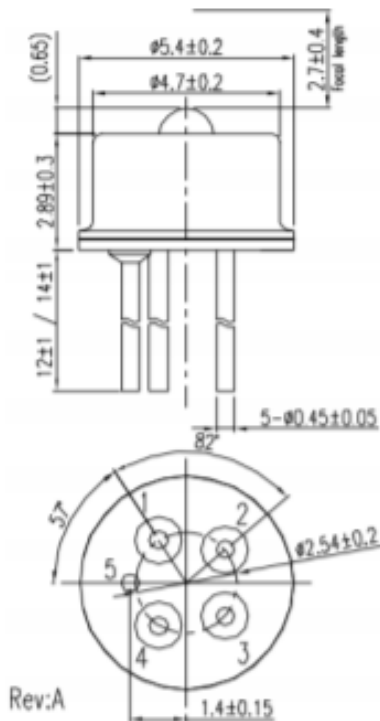

- Pinout:**
1. Dout
 2. Vcc
 3. Vapd
 4. Dout
 5. Gnd

Note: Specifications are subject to change without notice.