

Model No. LED-470P-ALA6M
470nm BLUE FIBER COUPLED LED SYSTEM

The LED-series 470nm blue fiber coupled LED system is constructed with features of stable output intensity, long lifetime and high power. It is widely used in spectroscopy, optogenetics, fluorescence excitation and many other applications.

SPECIFICATIONS

Model No.	LED-470P-ALA6M	
Nominal wavelength (nm)	470	
Color	Blue	
Bandwidth FWHM (nm)	25	
Fiber connector	SMA905	
Numerical aperture (NA)	0.22	
Typical $\phi 600\mu\text{m}$ core fiber output power SMA (mW)	3.2	
Maximum current CW (mA)	1000	
Forward voltage (V)	3.2	
Output power stability	<5%	
LED head	64 (L) x46.5 (W) x30 (H) mm ³	
Power supply	Input voltage	5V DC
	Dimensions	114 (L) x78 (W) x71 (H) mm ³
Operating mode	CW (M=C); CW with TTL modulation: 1Hz-1kHz (M=T1), 1kHz-10kHz (M=T2); CW with Analog modulation: 1Hz-1kHz (M=A1), 1kHz-10kHz (M=A2)	
Operating temperature (°C)	10 to 35 °C	
Typical lifetime (h)	~10,000	

Note: The above specifications are subject to change without notice.

MECHANICAL OUTLINE (unit: mm)

LED Head

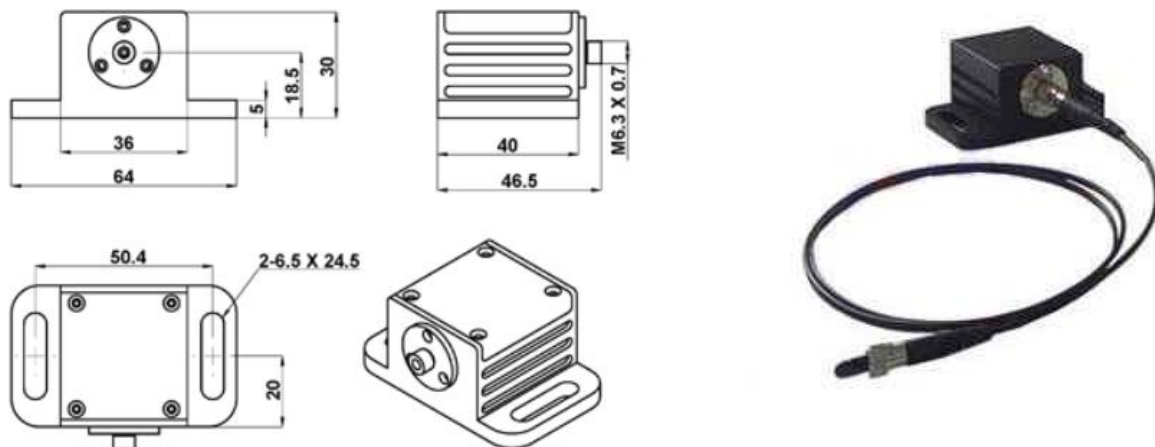



Power Supply

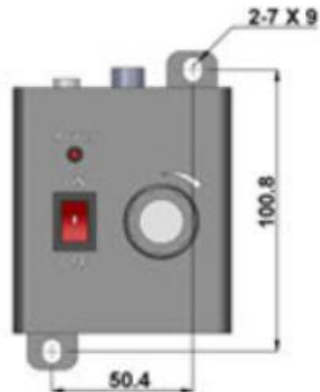
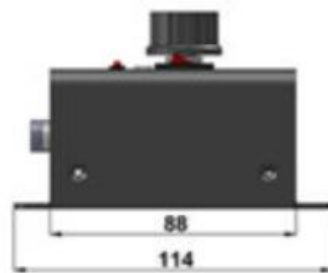
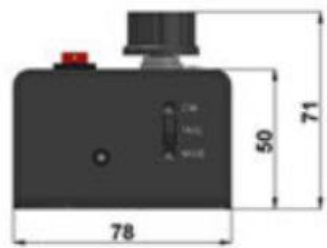

Note: The above specifications are subject to change without notice.