

**Model No. LD650A7C17 (LD-650-7A)  
650nm 7mW 70°C Laser Diode in TO-18  $\Phi$ 5.6mm Package****FEATURES**

- 650nm 7mW AlGaInP Visible Laser Diode
- High operating temperature
- High efficiency
- Low operating current
- Better power budget for optical design
- Package: TO-18 (dia. 5.6mm)

**APPLICATIONS**

- DVD player optical pick up
- DVD-ROM optical pick up
- Combo drive optical pick up
- Bar code scanner
- Printer
- PM2.5 detection (for indoor)

**ABSOLUTE MAXIMUM RATINGS**

PARAMETER	SYMBOL	CONDITION	RATING	UNIT
LIGHT OUTPUT POWER	$P_O$	CW	10	mW
REVERSE VOLTAGE (LD)	$V_{RL}$	-	2	V
REVERSE VOLTAGE (PD)	$V_{RD}$	-	30	V
FORWARD CURRENT (PD)	$I_{FD}$	-	10	mA
CASE TEMPERATURE	$T_C$	-	-10 to +70	°C
STORAGE TEMPERATURE	$T_S$	-	-40 to +85	°C

**ELECTRICAL AND OPTICAL CHARACTERISTICS ( $T_C = 25^\circ\text{C}$ )**

PARAMETER	SYMBOL	MIN.	TYP.	MAX.	UNIT	CONDITIONS
PEAK WAVELENGTH	$\lambda$	645	650	660	nm	$P_O = 7\text{mW}$
THRESHOLD CURRENT	$I_{th}$	-	20	25	mA	
OPERATING CURRENT	$I_{op}$	-	27	35	mA	$P_O = 7\text{mW}$
OPERATING VOLTAGE	$V_{op}$	-	2.2	2.5	V	$P_O = 7\text{mW}$
DIFFERENTIAL EFFICIENCY	$\eta$	0.7	1.0	1.2	mW/mA	$P_O = 3\text{-}5\text{mW}$
MONITOR CURRENT	$I_m$	0.1	0.15	0.3	mA	$P_O = 7\text{mW}$ , $V_{RD} = 5\text{V}$
PARALLEL DIVERGENCE ANGLE	$\Theta_{//}$	6	9	12	deg	
PERPENDICULAR DIVERGENCE ANGLE	$\Theta_{\perp}$	25	28	32	deg	
PARALLEL FFP DEVIATION ANGLE	$\Delta \Theta_{//}$	-3	0	+3	deg	$P_O = 7\text{mW}$
PERPENDICULAR FFP DEVIATION ANGLE	$\Delta \Theta_{\perp}$	-3	0	+3	deg	
EMISSION POINT ACCURACY	$\Delta x \Delta y \Delta z$	-80	0	+80	um	

**Note: The above specifications are subject to change without notice.**



### MECHANICAL OUTLINE (unit: mm)

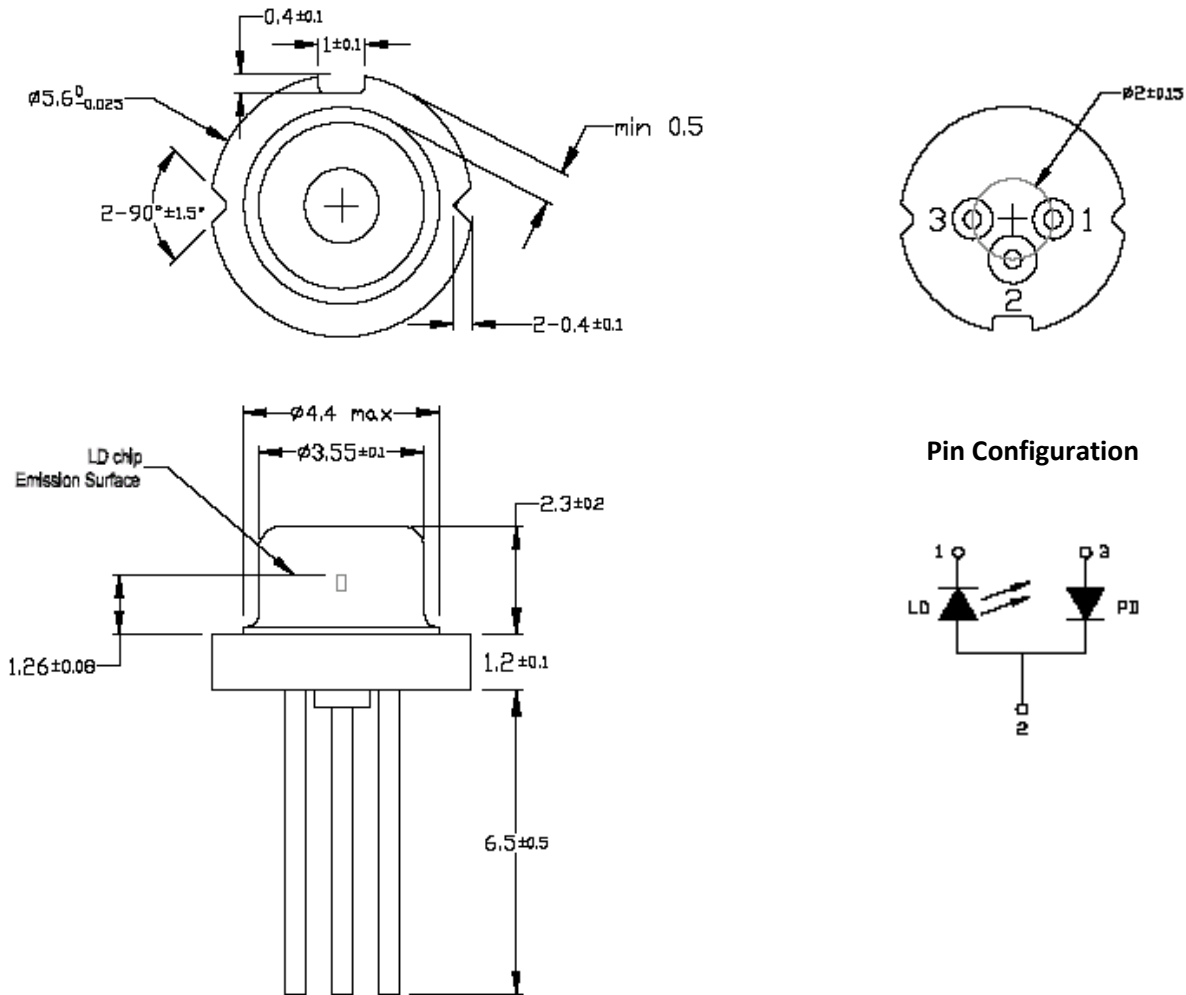

### PRECAUTIONS

- Do not operate the device above maximum ratings. Doing so may cause unexpected and permanent damage to the device.
- Take precautions to avoid electrostatic discharge and/or momentary power spikes. A change in the characteristics of the laser or premature failure may result.
- Proper heat sinking of the device assures stability and lifetime. Always ensure that maximum operating temperatures are not exceeded.
- Observing visible or invisible laser beams with human eye directly, or indirectly, can cause permanent damage. Use a camera to observe the laser.
- No laser device should be used in any application or situation where life or property is at risk in the event of device failure.
- Specifications are subject to change without notice. Ensure that you have the latest specification by contacting us prior to purchase or use of the product.

**Note: The above specifications are subject to change without notice.**





TYPICAL CHARACTERISTICS

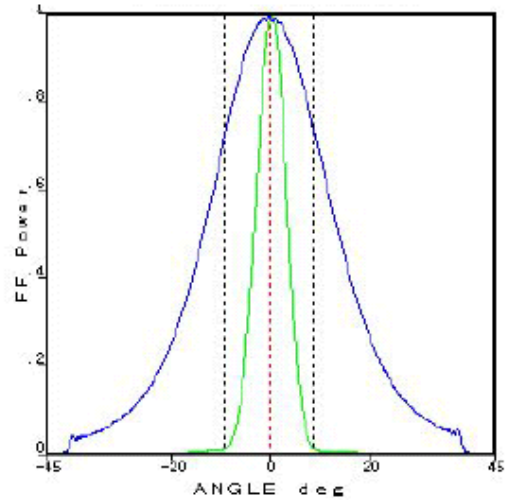
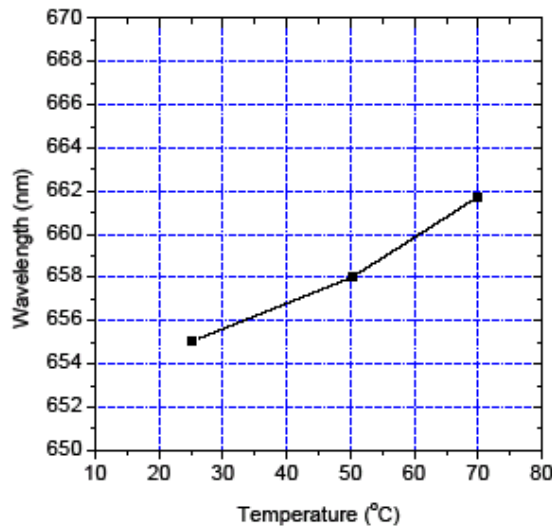
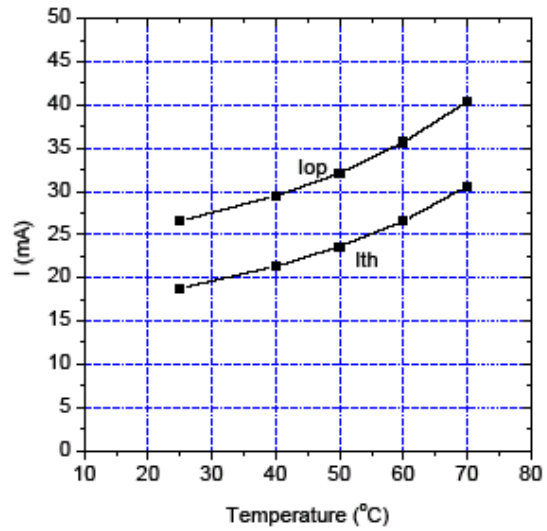
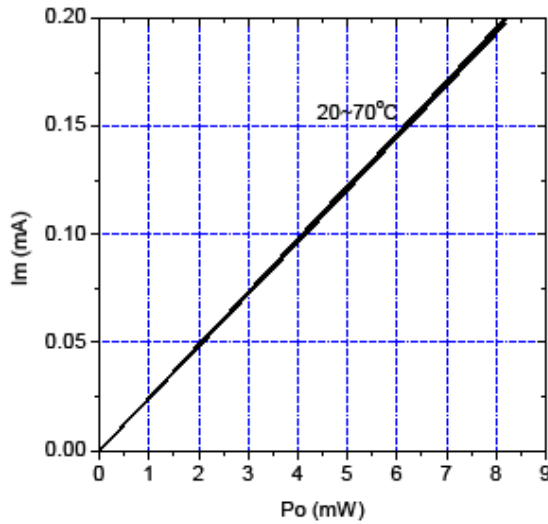
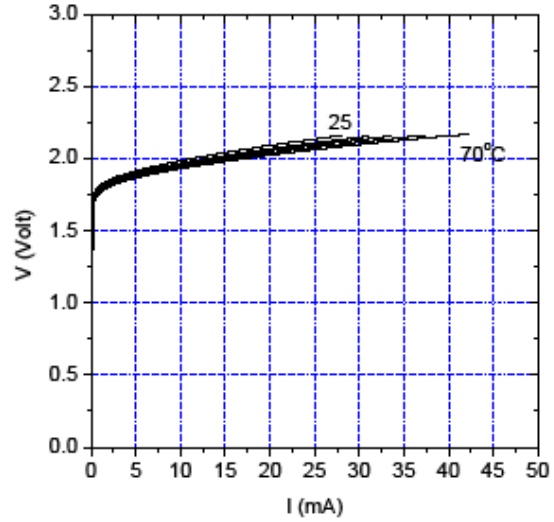
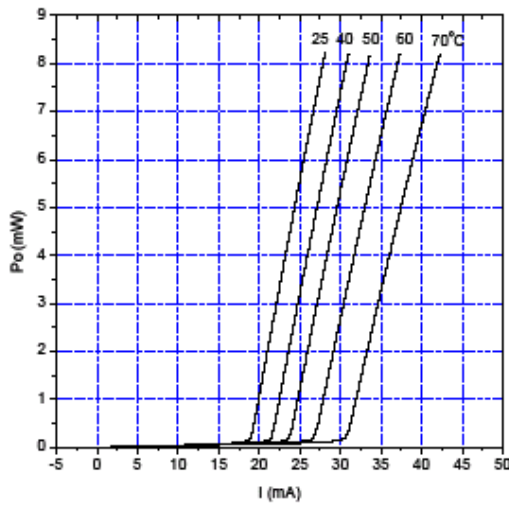

Note: The above specifications are subject to change without notice.

