



10GBASE-ER/EW 1550nm SMF 40km SFP+ Optical Transceiver with Duplex LC Connector

Model No. 10GERSFPx

FEATURES

- Compliant with SFF8472 diagnostic monitoring interface
- Duplex LC connector
- Hot pluggable
- Class 1 laser product compliant with EN 60825-1
- Support CPRI line bit rate option 7: 9830.4 Mbit/s
- Single power supply 3.3V
- Up to 40km transmission on SMF



DIAGNOSTICS

PARAMETER	RANGE	ACCURACY	UNIT	CALIBRATION
Internal Transceiver Temperature	-40 to 95	±3	°C	Internal
Internal Transceiver Voltage	3.14 to 3.46	±0.1	V	
Bias Current	0 to 120	±10%	mA	
TX Power	-4.7 to +4.7	±3	dB	
RX Average Power	-1 to -16	±3	dB	

ABSOLUTE MAXIMUM RATINGS

PARAMETER	SYMBOL	MIN	MAX	UNIT
Storage Temperature	T _S	-40	85	°C
Supply Voltage	V _{CC}	0	3.6	V
Input Voltage	V _{IN}	0	V _{CC}	V
Operating Relative Humidity	RH	0	85	%

RECOMMENDED OPERATING CONDITIONS

PARAMETER	SYMBOL	MIN	MAX	UNIT	Notes
Case Operating Temperature	T _C	0	70	°C	10GERSFPC
		-40	85		10GERSFPI
Supply Voltage	V _{CC}	3.14	3.46	V	
Supply Current	I _{TX} + I _{RX}		450	mA	
Power Consumption	P	-	1.5	W	

**TRANSMITTER ELECTRO-OPTICAL CHARACTERISTICS ($V_{CC} = 3.14V$ to $3.46V$, $T_C = 0^{\circ}C$ to $70^{\circ}C$, $-40^{\circ}C$ to $85^{\circ}C$)**

PARAMETER	SYMBOL	MIN	TYP.	MAX	UNIT
Data Rate	B		10.3125		Gbps
Output Optical Power (Average)	P_{out}	-4.7	-	+4.0	dBm
Output Optical Power (OMA)	P_{out}	-1.7	-	-	dBm
Extinction Ratio	ER	6			dB
Center Wavelength	λ_c	1530	-	1565	nm
Spectral Width (RMS)	$\Delta\lambda$	-	-	1	nm
Side Mode Suppression Ratio	SSR_{min}	30			dB
Transmitter and Dispersion Penalty	TDP			2	dB
Relative Intensity Noise	RIN	-	-	-128	dB/Hz
Optical Return Loss	ORL	21	-	-	dB
Output Eye		Compliant with IEEE802.3ae			
Differential Input Impedance	Z_d		100		Ω
Differential Input Voltage Swing	V_{DIFF}	300		1000	mVpp
Transmit Fault Output-Low	TX_FAULT_L	0.0	-	0.5	V
Transmit Fault Output-High	TX_FAULT_H	2.4	-	V_{CC}	V
TX_DISABLE Assert Time	t_{off}	-	-	100	μs
TX_DISABLE Negate Time	t_{on}	-	-	2	ms
TX_FAULT from fault to assertion	t_{fault}	-	-	50	ms
TX_DISABLE Time to start reset	t_{reset}	10	-	-	μs

RECEIVER ELECTRO-OPTICAL CHARACTERISTICS ($V_{CC} = 3.14V$ to $3.46V$, $T_C = 0^{\circ}C$ to $70^{\circ}C$, $-40^{\circ}C$ to $85^{\circ}C$)

PARAMETER	SYMBOL	MIN	TYP.	MAX	UNIT	NOTES
Data Rate	B		10.3125		Gbps	
Optical Input Power – maximum	P_{IN}	-1.0	-	-	dBm	BER<10 ⁻¹²
Receiver Sensitivity@10.3125 Gbps	P_{IN}	-	-	-15.8	dBm	BER<10 ⁻¹²
Receiver Sensitivity (OMA)	P_{IN}	-	-	-14.1	dBm	BER<10 ⁻¹²
Stressed Receiver Sensitivity (OMA)	P_{IN}	-	-	-11.3	dBm	BER<10 ⁻¹²
Operating Center Wavelength	λ_c	1530	-	1565	nm	
Loss of Signal-Asserted	P_A	-30	-	-	dBm	
Loss of Signal-Deasserted	P_D	-	-	-18	dBm	
Differential Output Impedance	Z_d	-	100	-	Ω	
Differential Output Voltage	V_{DIFF}	300	-	800	mVpp	
Receiver Loss of Signal Output Voltage-Low	RX_LOS_L	0	-	0.5	V	
Receiver Loss of Signal Output Voltage-High	RX_LOS_H	2.4	-	V_{CC}	V	
Receiver Loss of Signal Assert Time (off to on)	t_{A,RX_LOS}	-	-	100	μs	
Receiver Loss of Signal Assert Time (on to off)	t_{D,RX_LOS}	-	-	100	μs	

TIMING PARAMETERS

PARAMETER	SYMBOL	MIN	TYP.	MAX	UNIT	NOTES
Time to Initialize	t_{start_up}			10	s	



DIGITAL DIAGNOSTIC MEMORY MAP

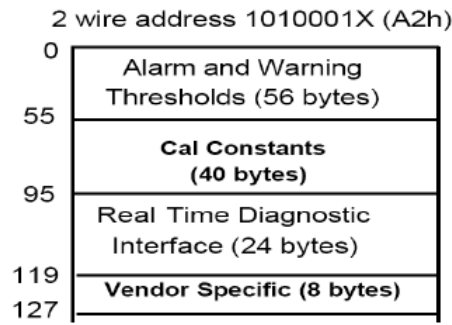
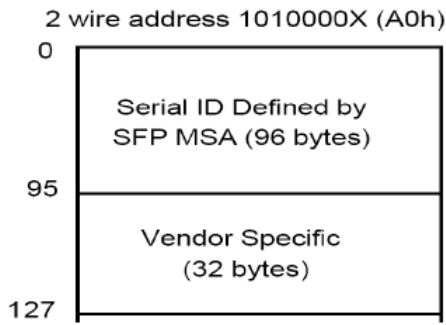

EEPROM Serial ID Memory Contents (A0h)

Address	Hex	Fields	Result
0	03(H)	identifier	SFP or SFP+ or SFP28
1	04(H)	Ext.Identifier	GBIC/SFP function is defined by two-wire interface ID only
2	07(H)	Connector	LC
3	20(H)	Transceiver	10G Base-ER;
4	00(H)	Unallocated	Unallocated
5	00(H)		
6	00(H)		
7	00(H)		
8	00(H)		
9	00(H)		
10	00(H)		
11	06(H)	Encoding	64B/66B
12	67(H)	BR(Nominal)	10300Mbps
13	00(H)	Rate Identifier	Unspecified
14	0A(H)	Length(SMFm)-km	40(units of km)
15	64(H)	Length(SMF)	255(units of 100m)
16	00(H)	Length(50µm)	N/A
17	00(H)	Length(62.5µm)	N/A
18	00(H)	Length(cable)	N/A
19	00(H)	Length(OM3)	N/A
20	4D(H)	Vendor name	A
21	4F(H)	Vendor name	P
22	58(H)	Vendor name	A
23	41(H)	Vendor name	C
24	20(H)	Vendor name	



25	20(H)	Vendor name	O
26	20(H)	Vendor name	p
27	20(H)	Vendor name	t
28	20(H)	Vendor name	o
29	20(H)	Vendor name	
30	20(H)	Vendor name	
31	20(H)	Vendor name	
32	20(H)	Vendor name	
33	20(H)	Vendor name	
34	20(H)	Vendor name	
35	20(H)	Vendor name	
36	00(H)	Transceiver	Unallocated
37	00(H)	Vendor OUI	00
38	00(H)	Vendor OUI	0F
39	00(H)	Vendor OUI	99
40	53(H)	Vendor PN	L
41	46(H)	Vendor PN	E
42	50(H)	Vendor PN	4
43	2D(H)	Vendor PN	8
44	31(H)	Vendor PN	-
45	30(H)	Vendor PN	H
46	47(H)	Vendor PN	3
47	4C(H)	Vendor PN	L
48	52(H)	Vendor PN	-
49	4C(H)	Vendor PN	T
50	43(H)	Vendor PN	C
51	2D(H)	Vendor PN	-
52	54(H)	Vendor PN	N
53	20(H)	Vendor PN	
54	20(H)	Vendor PN	
55	20(H)	Vendor PN	
56	30(H)	Vendor rev	0
57	30(H)	Vendor rev	0
58	30(H)	Vendor rev	0
59	30(H)	Vendor rev	0
60	05(H)	Wavelength	1550nm
61	1E(H)	Wavelength	
62	00(H)	Unallocated	Unallocated
63		CC_BASE	E5
64	00(H)	Options	Cooled Transceiver Declaration
65	1A(H)	Options	Loss of Signal;Tx_Fault;Tx_Disable;
66	00(H)	BR	Max
67	00(H)	BR	Min
68		Vendor SN	0



69			1
70			2
71			3
72			4
73			5
74			6
75			7
76			8
77			9
78			A
79			B
80			C
81			D
82			E
83			F
84		Date code	0
85			7
86			0
87			1
88			0
89			1
90			
91			
92	68(H)	Diagnostic Monitoring Type	Received Average Power Measurement Type; Internally Calibrated; Digital diagnostic monitoring implemented;
93	B0(H)	Enhanced Options	Rx_Loss Monitoring; Tx_Fault Monitoring; Tx_Disable Contorl; Alarm/warning Flags;
94	03(H)	SFF-8472 Compliance	includes functionality described in Rev 11.0 of SFF-8472
95		CC_EXT	86
96	4D(H)	Vendor Specific	E
97	6F(H)	Vendor Specific	X
98	78(H)	Vendor Specific	T
99	61(H)	Vendor Specific	R
100	6E(H)	Vendor Specific	E
101	65(H)	Vendor Specific	M
102	74(H)	Vendor Specific	E
103	20(H)	Vendor Specific	L



104	53(H)	Vendor Specific	Y
105	46(H)	Vendor Specific	
106	50(H)	Vendor Specific	C
107	2D(H)	Vendor Specific	O
108	31(H)	Vendor Specific	M
109	30(H)	Vendor Specific	P
110	47(H)	Vendor Specific	A
111	4C(H)	Vendor Specific	T
112	52(H)	Vendor Specific	I
113	4C(H)	Vendor Specific	B
114	43(H)	Vendor Specific	L
115	2D(H)	Vendor Specific	E
116	54(H)	Vendor Specific	E
117	00(H)	Vendor Specific	X
118	00(H)	Vendor Specific	T
119	00(H)	Vendor Specific	R
120	00(H)	Vendor Specific	E
121	00(H)	Vendor Specific	M
122	00(H)	Vendor Specific	E
123	00(H)	Vendor Specific	
124	00(H)	Vendor Specific	
125	00(H)	Vendor Specific	
126	00(H)	Vendor Specific	
127	00(H)	Vendor Specific	



EEPROM Serial ID Memory Contents (A2h)

For $T_c = -40^{\circ}\text{C}$ to 85°C

Address(A2h)	Description	Value
00-01	Temp High Alarm	80 Degree C
02-03	Temp Low Alarm	-10 Degree C
04-05	Temp High Warning	75 Degree C
06-07	Temp Low Warning	-5 Degree C
08-09	Voltage High Alarm	3.6 V
10-11	Voltage Low Alarm	3.0 V
12-13	Voltage High Warning	3.5 V
14-15	Voltage Low Warning	3.1 V
16-17	Bias High Alarm	100 mA
18-19	Bias Low Alarm	30 mA
20-21	Bias High Warning	90 mA
22-23	Bias Low Warning	40 mA
24-25	TX Power High Alarm	+3 dBm
26-27	TX Power Low Alarm	-2 dBm
28-29	TX Power High Warning	+2 dBm
30-31	TX Power Low Warning	-1 dBm
32-33	RX Power High Alarm	0 dBm
34-35	RX Power Low Alarm	-17 dBm
36-37	RX Power High Warning	-1 dBm
38-39	RX Power Low Warning	-16 dBm
40-55	Reserved Reserved for future monitored quantities	
56-91	External calibration constant	
92-94	Reserved	
95	Check sum	
96-97	Real Time temperature	
98-99	Real Time supply voltage	
100-101	Real Time TX bias current	
102-103	Real Time TX optical power	
104-105	Real Time RX received power	
106-109	Reserved	
110(bit7)	NA	
110(bit6)	NA	
110(bit5)	Reserved	
110(bit4)	NA	
110(bit3)	NA	
110(bit2)	Digital state of TX fault output pin	
110(bit1)	Digital state of LOS output pin	
110(bit0)	NA	

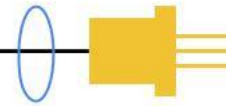

111	Reserved	
112(bit7)	Set when internal temperature exceeds high alarm level	
112(bit6)	Set when internal temperature exceeds is below alarm level	
112(bit5)	Set when internal supply voltage exceeds high alarm level	
112(bit4)	Set when internal supply voltage is below alarm level	
112(bit3)	Set when TX bias exceeds high alarm level	
112(bit2)	Set when TX bias voltage is below alarm level	
112(bit1)	Set when TX output power exceeds high alarm level	
112(bit0)	Set when TX output power voltage is below alarm level	
113(bit7)	Set when RX received power exceeds high alarm level	
113(bit6)	Set when RX received power is below alarm level	
113(bit5-0)	Reserved	
114-115	Reserved	
116(bit7)	Set when internal temperature exceeds high warning level	
116(bit6)	Set when internal temperature exceeds is below warning level	
116(bit5)	Set when internal supply voltage exceeds high warning level	
116(bit4)	Set when internal supply voltage is below warning level	
116(bit3)	Set when TX bias exceeds high warning level	
116(bit2)	Set when TX bias voltage is below warning level	
116(bit1)	Set when TX output power exceeds high warning level	
116(bit0)	Set when TX output power voltage is below warning level	
117(bit7)	Set when RX received power exceeds high warning level	
117(bit6)	Set when RX received power is below warning level	
117(bit5-0)	Reserved	
118-119	Reserved	
120-127	Reserved	

DIMENSIONS (unit: mm)

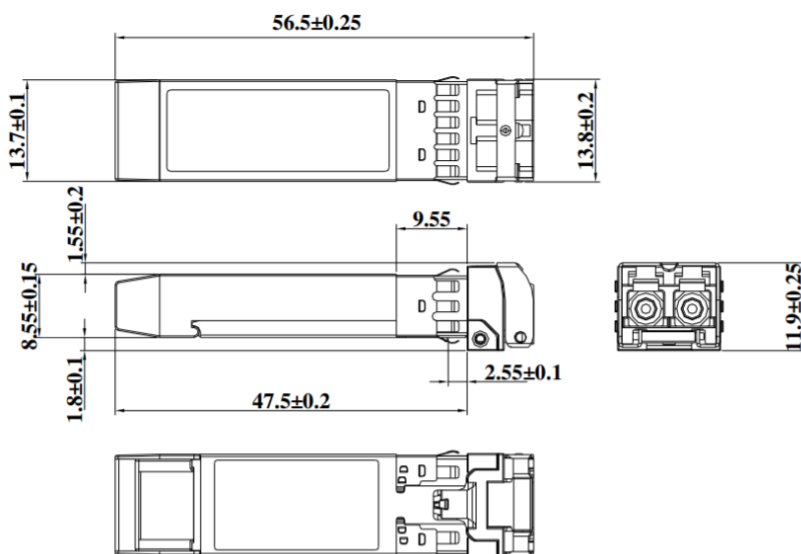



SFP HOST BOARD MECHANICAL LAYOUT (unit: mm)

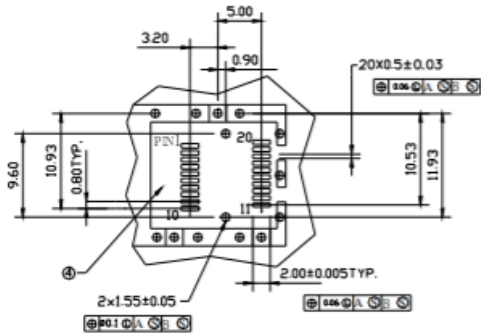
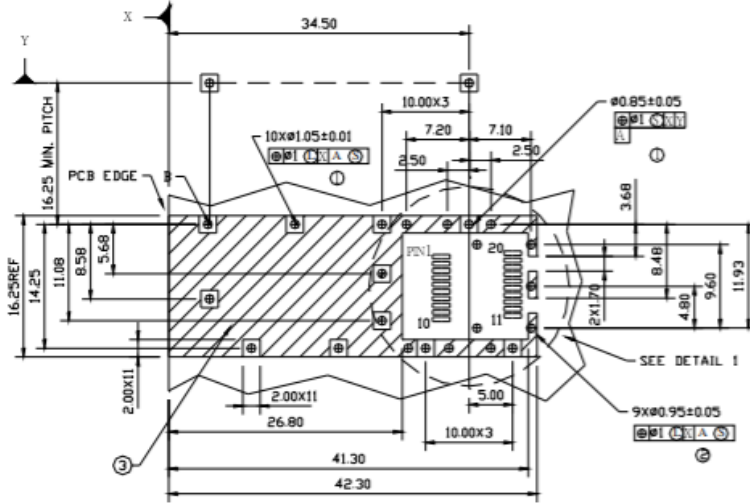

LEGEND

- 1.PADS AND VIAS ARE CHASSIS GROUND
- 2.THROUGH HOLES, PLATING OPTIONAL
- 3.HATCHED AREA DENOTES COMPONENT AND TRACE KEEPOUT(EXCEPT CHASSIS GROUND)
- 4.AREA DENOTES COMPONENT KEEPOUT (TRACES ALLOWED)

DIMENSIONS ARE IN MILLIMETERS

ASSEMBLY DRAWING

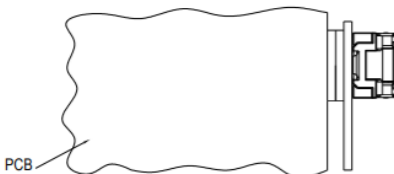
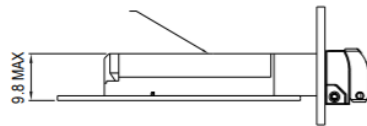
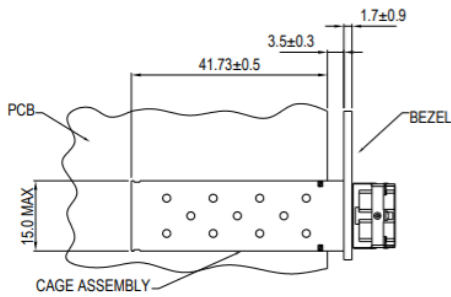

DIMENSIONS ARE IN MILLIMETERS

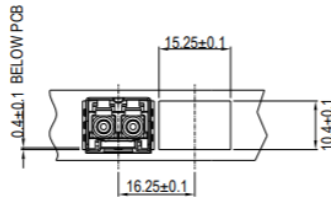

MSA-SPECIFIED BEZEL

Lasermate Group, Inc.

19608 Camino De Rosa, Walnut, CA 91789, USA

Tel: (909)718-0999 | Fax: (909)718-0998 | E-mail: info@lasermate.com | URL: <http://www.lasermate.com>



RECOMMENDED INTERFACE CIRCUIT

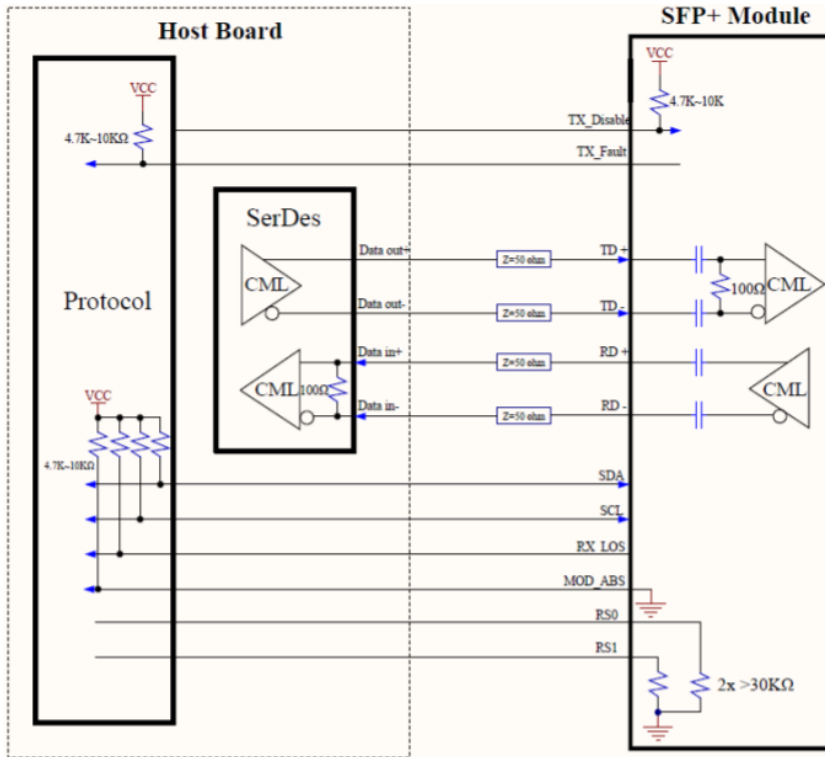

PIN ASSIGNMENT

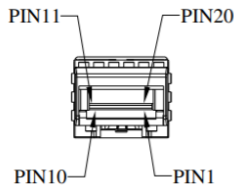

PIN	SIGNAL NAME	DESCRIPTION	PIN	SIGNAL NAME	DESCRIPTION
1	T _{GND}	Transmit Ground	11	R _{GND}	Receiver Ground
2	TX_FAULT	Transmit Fault	12	RX-	Receive Data out Bar, ac coupled
3	TX_DISABLE	Transmit Disable	13	RX+	Receive Data out, ac coupled
4	MOD_DEF (2)	SDA Serial Data Signal	14	R _{GND}	Receiver Ground
5	MOD_DEF (1)	SCL Serial Clock Signal	15	V _{CCR}	Receiver Power Supply
6	MOD_DEF (0)	TTL Low	16	V _{CCT}	Transmitter Power Supply
7	RS0	RX Rate Select, no function implemented	17	T _{GND}	Transmitter Ground
8	RX_LOS	Receiver Loss of Signal, TTL High, open collector	18	TX+	Transmit Data in, ac coupled
9	RS1	TX Rate Select, no function implemented	19	TX-	Transmit Data in Bar, ac coupled
10	R _{GND}	Receiver Ground	20	T _{GND}	Transmitter Ground

Lasermate Group, Inc.

19608 Camino De Rosa, Walnut, CA 91789, USA

Tel: (909)718-0999 | Fax: (909)718-0998 | E-mail: info@lasermate.com | URL: <http://www.lasermate.com>



Lasermate Group, Inc.

The Friend of Lasers



ORDERING INFORMATION

PART NUMBER	OPERATING TEMPERATURE
10GERSFPC	0°C to 70°C
10GERSFPI	-40°C to 85°C

Note: The specifications subject to change without notice.

Lasermate Group, Inc.

19608 Camino De Rosa, Walnut, CA 91789, USA

Tel: (909)718-0999 | Fax: (909)718-0998 | E-mail: info@lasermate.com | URL: <http://www.lasermate.com>