



10GBASE-BX TX:1270nm/RX:1330nm SMF 60km BiDi SFP+ LC Optical Transceiver

Model No. 10G2T3-USFPC-L

FEATURES

- 10.3125Gbps application
- Compliant with SFF 8432 SFP+ Module
- Simplex LC connector
- Single power supply 3.3V
- LVTTTL signal detect indicator
- Hot Pluggable
- Class 1 laser product compliant with EN 60825-1
- Reliability compliant with Telcordia (Bellcore) GR-468-CORE
- Temperature: 0°C to 70°C
- Distance: 60km (Note: Attenuation of 0.35dB/km @1270nm is used for the link length calculations.)



DIAGNOSTICS

PARAMETER	RANGE	ACCURACY	UNIT	CALIBRATION
Internal Transceiver Temperature	-10 to 95	±3	°C	Internal
Internal Transceiver Voltage	3.1 to 3.5	±0.1	V	
Bias Current	0 to 100	±10%	mA	
TX Power	+2.5 to +7	±3	dB	
RX Average Power	-21.5 to -7	±3	dB	

ABSOLUTE MAXIMUM RATINGS

PARAMETER	SYMBOL	MIN	MAX	UNIT
Storage Temperature	T _S	-40	85	°C
Supply Voltage	V _{CC}	-0.5	4.0	V
Input Voltage	V _{IN}	-0.5	V _{CC}	V

RECOMMENDED OPERATING CONDITIONS

PARAMETER	SYMBOL	MIN	MAX	UNIT	NOTES
Case Operating Temperature	T _C	0	70	°C	
Supply Voltage	V _{CC}	3.14	3.46	V	
Supply Current	I _{TX} + I _{RX}		350	mA	
Dispersion Penalty			1	dB	@60km

Lasermate Group, Inc.

19608 Camino De Rosa, Walnut, CA 91789, USA

Tel: (909)718-0999 | Fax: (909)718-0998 | E-mail: info@lasermate.com | URL: <http://www.lasermate.com>

**TRANSMITTER ELECTRO-OPTICAL CHARACTERISTICS ($V_{CC} = 3.14V$ to $3.46V$, $T_C = 0^{\circ}C$ to $70^{\circ}C$)**

PARAMETER	SYMBOL	MIN	TYP.	MAX	UNIT	NOTES
Bit Rate	B	-	10.3125	-	Gbps	
Output Optical Power	P_{out}	+2.5	-	+7	dBm	Average
Extinction Ratio	ER	6	-	-	dB	
Center Wavelength	λ_C	1260	1270	1280	nm	
Spectral Width (-20dB)	$\Delta\lambda$	-	-	0.5	nm	
Side Mode Suppression Ratio	SMSR	30			dB	
Max. P_{out} TX-DISABLE Asserted	P_{OFF}	-	-	-45	dBm	
Differential Input Voltage	V_{DIFF}	180		850	mV	
Transmit Fault Output-Low	TX_FAULT _L	0.0	-	0.5	V	
Transmit Fault Output-High	TX_FAULT _H	2.4	-	V_{CC}	V	
TX_DISABLE Assert Time	t_{off}	-	-	100	μs	
TX_DISABLE Negate Time	t_{on}	-	-	2	ms	
Time to Initialize, include reset of TX_FAULT	t_{init}	-	-	300	ms	
TX_FAULT from fault to assertion	t_{fault}	-	-	1	ms	
TX_DISABLE Time to start reset	t_{reset}	10	-	-	μs	

RECEIVER ELECTRO-OPTICAL CHARACTERISTICS ($V_{CC} = 3.14V$ to $3.46V$, $T_C = 0^{\circ}C$ to $70^{\circ}C$)

PARAMETER	SYMBOL	MIN	TYP.	MAX	UNIT	NOTES
Bit Rate	B	-	10.3125	-	Gbps	
Optical Input Power-Maximum	P_{IN}	-7	-	-	dBm	BER<10 ⁻¹²
Optical Input Power-Minimum (Sensitivity)	P_{IN}	-	-	-21.5	dBm	BER<10 ⁻¹²
Operating Center Wavelength	λ_C	1320	-	1340	nm	
Optical Return Loss	ORL	14	-	-	dB	
Loss of Signal-Asserted	P_A	-35	-	-	dBm	
Loss of Signal-Deasserted	P_D	-	-	-21.5	dBm	
Differential Output Voltage	V_{DIFF}	350	-	850	mV	
Receiver Loss of Signal Output Voltage-Low	RX_LOS _L	0	-	0.5	V	
Receiver Loss of Signal Output Voltage-High	RX_LOS _H	2.4	-	V_{CC}	V	
Receiver Loss of Signal Assert Time (off to on)	t_{A,RX_LOS}	-	-	100	us	
Receiver Loss of Signal Assert Time (on to off)	t_{D,RX_LOS}	-	-	100	us	



BLOCK DIAGRAM OF TRANSCEIVER

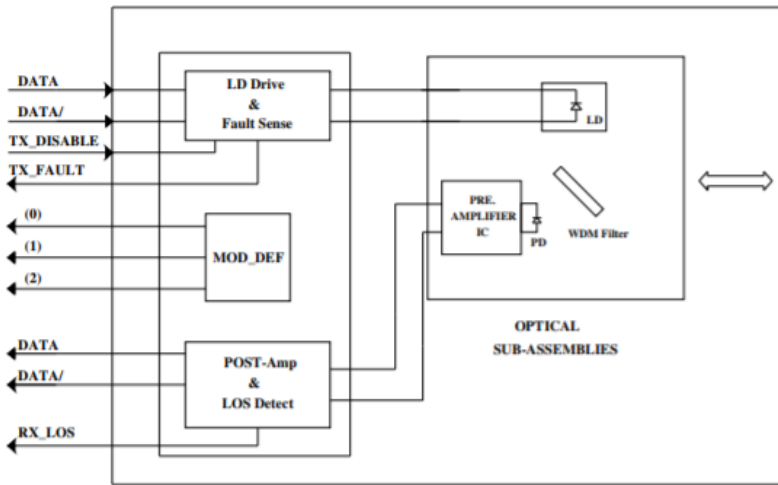

Transmitter and Receiver Optical Sub-assembly Section - A 1270 nm InGaAsP laser and an InGaAs Avalanche photodiode integrate with an WDM filter to form a bi-directional single fiber optical subassembly (OSA). The laser of OSA is driven by a LD driver IC which converts differential input LVPECL logic signals into an analog laser driving current. And, The photodiode of OSA is connected to a circuit providing post-amplification quantization, and optical signal detection.

TX_DISABLE - The TX_DISABLE signal is high (LVTTTL logic "1") to turn off the laser output.

Receive Loss (RX_LOS) - The RX_LOS is high (logic "1") when there is no incoming light from the companion transceiver. This signal is normally used by the system for the diagnostic purpose. The signal is operated in LVTTTL level.

DIMENSIONS

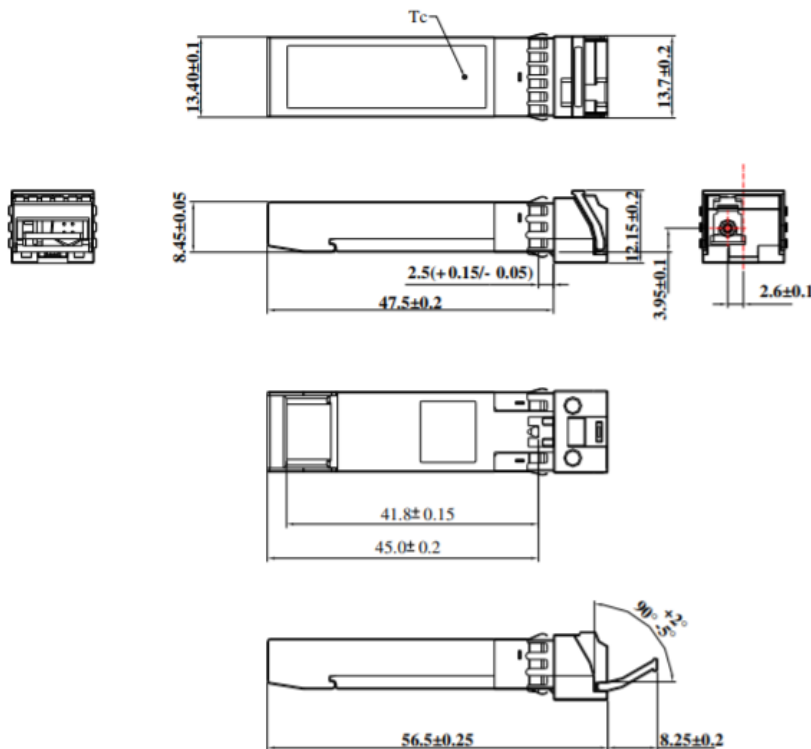

Lasermate Group, Inc.

19608 Camino De Rosa, Walnut, CA 91789, USA

Tel: (909)718-0999 | Fax: (909)718-0998 | E-mail: info@lasermate.com | URL: <http://www.lasermate.com>



SFP HOST BOARD MECHANICAL LAYOUT

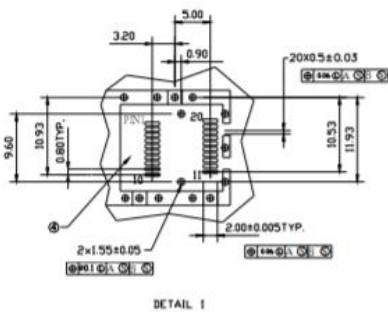
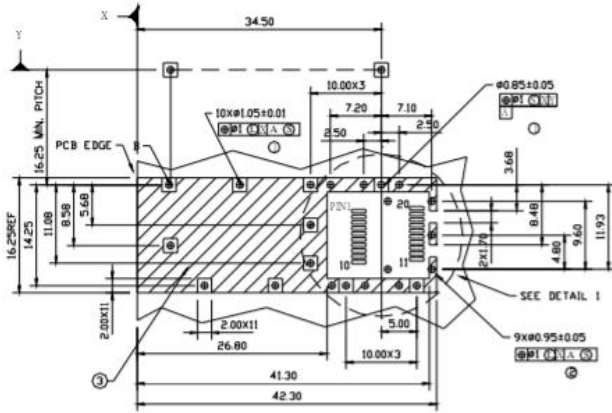

LEGEND

1. PADS AND VIAS ARE CHASSIS GROUND
2. THROUGH HOLES, PLATING OPTIONAL
3. HATCHED AREA DENOTES COMPONENT AND TRACE KEEPOUT (EXCEPT CHASSIS GROUND)
4. AREA DENOTES COMPONENT KEEPOUT (TRACES ALLOWED)

DIMENSIONS ARE IN MILLIMETERS

Unit: mm

ASSEMBLY DRAWING

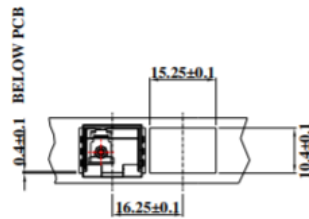
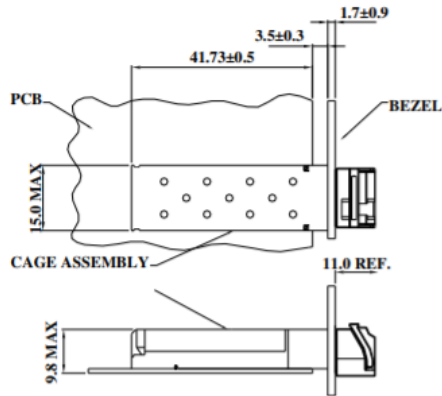

MSA-SPECIFIED BEZEL

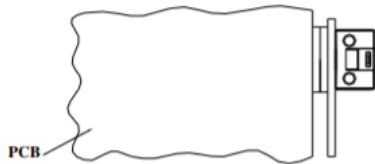

DIMENSIONS ARE IN MILLIMETERS

Unit: mm

Lasermate Group, Inc.

19608 Camino De Rosa, Walnut, CA 91789, USA

Tel: (909)718-0999 | Fax: (909)718-0998 | E-mail: info@lasermate.com | URL: <http://www.lasermate.com>



PIN ASSIGNMENT

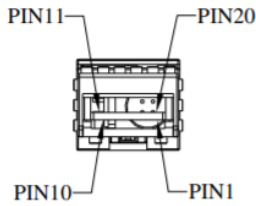

Pin	Signal Name	Description
1	T_{GND}	Transmit Ground
2	TX_FAULT	Transmit Fault
3	$TX_DISABLE$	Transmit Disable
4	SDA	SDA Serial Data Signal
5	SCL	SCL Serial Clock Signal
6	MOD_ABS	Internal connected to ground
7	$RS0$	Rate select 0, not used
8	RX_LOS	Receiver Loss of Signal, LVTTTL High, open collector
9	$RS1$	Rate select 1, not used
10	R_{GND}	Receiver Ground
11	R_{GND}	Receiver Ground
12	$RX-$	Receive Data Bar, ac coupled
13	$RX+$	Receive Data, ac coupled
14	R_{GND}	Receiver Ground
15	V_{CCR}	Receiver Power Supply
16	V_{CCT}	Transmitter Power Supply
17	T_{GND}	Transmitter Ground
18	$TX+$	Transmit Data, ac coupled
19	$TX-$	Transmit Data Bar, ac coupled
20	T_{GND}	Transmitter Ground

Note: The specifications subject to change without notice.