



100GBASE-SR4 850nm MMF 100m QSFP28 Optical Transceiver with Duplex MPO Connector

Model No. 100GSRSFPCM

DESCRIPTION

The QSFP28 100GBASE-SR4 Transceiver product is a new high-speed module with a MPO connector. This interconnecting module offers 4 channels and maximum bandwidth of 100Gbps. The TRxs utilize multimode fiber with 850-nm VCSELs and PIN PDs. This module provides high performance and excellent efficiency in the optical communication.

FEATURES

- Compliant with 100G Ethernet IEEE 802.3bm 100GBASE-SR4 standards
- Compliant to SFF-8636 QSFP28 MSA
- QSFP footprint (Quad small form-factor, pluggable)
- Power consumption <3.5W
- Full Digital Diagnostics Monitor Interface
- Case Temperature Operating Range: 0°C to 70°C
- Hot pluggable electrical interface
- RoHS-6 Compliant
- Distance: OM3=70m/OM4=100m



APPLICATION

- 100GBASE-SR4 Ethernet links
- Infiniband EDR, FDR & QDR interconnects

ABSOLUTE MAXIMUM RATINGS

PARAMETER	SYMBOL	MIN	MAX	UNIT
Storage Temperature	T _s	-40	85	°C
3.3V Power Supply Voltage	V _{CC}	-0.5	3.6	V
Data Input Voltage – Single Ended		-0.5	V _{CC} +0.5	V
Relative Humidity	RH	5	85	%

Note: Exceeding these values may cause permanent damage. Function operation under these conditions is not implied.

**RECOMMENDED OPERATING CONDITIONS**

PARAMETER	SYMBOL	MIN	TYP.	MAX	UNIT
Case Operating Temperature	T _c	0		70	°C
3.3V Power Supply Voltage	V _{CC}	3.14	3.3	3.46	V
Signal Rate per Channel	B		25.78125		Gb/s
Control Input Voltage High	V _{ih}	2		V _{CC} +0.3	V
Control Input Voltage Low	V _{il}	-0.3		0.8	V
Two Wire Serial (TWS) Interface Clock Rate				400	KHz
Receiver Differential Data Output Load	Z _d		100		Ohms
Power Supply Current	I _{CC}			1060	mA
Power Consumption	P	-		3.5	W

TRANSMITTER ELECTRO-OPTICAL CHARACTERISTICS

PARAMETER	SYMBOL	MIN	TYP.	MAX	UNIT	NOTES
Center Wavelength	λ _c	840		860	nm	
Spectral Width (RMS)	Δλ			0.6	nm	
Average Output Power, each lane	P _{out}	-8.4		+2.4	dBm	
Optical Modulation Amplitude (OMA)	POMA	-6.4		+3	dBm	
Launch power in OMA minus TDEC, each lane		-7.3			dBm	
Transmitter and dispersion eye closure (TDEC), each lane	TDEC			4.3	dB	
Optical Extinction Ratio	ER	2			dB	
Disabled Output Optical Power	PO_OFF			-30	dBm	
Eye Mask Coordinates: X1, X2, X3; Y1, Y2, Y3		0.3, 0.38, 0.45, 0.35, 0.41, 0.5			UI	(1)
Optical Return Loss Tolerance				12	dB	
Differential Data Input Voltage	V _{DIFF}	300		900	mV	

RECEIVER ELECTRO-OPTICAL CHARACTERISTICS

PARAMETER	SYMBOL	MIN	TYP.	MAX	UNIT	NOTES
Center Wavelength, each lane	λ _c	840	850	860	nm	
Damage Threshold	DTH	3.4			dBm	
Average Receiver Power, each lane	PIN_AVG	-10.3		+2.4	dBm	(2)
Stressed Sensitivity (OMA)	PIN_s-oma			-5.2	dBm	(3)
LOS Assert	P _A	-30			dBm	
LOS De-Assert	P _D			-11	dBm	
LOS Hysteresis		0.5			dBm	
Rise & Fall Time (20%~80%)	Tr/Tf			35	ps	
Differential Data Output Voltage	V _{out,pp}	300		900	mV	

Notes:

1. Hit ratio = 5x10⁻⁵ per sample
2. Average receive power, each lane (min) is informative and not the principal indicator of signal strength.
3. Measured with conformance test signal for BER=5x10⁻⁵



PAD ASSIGNMENT AND DESCRIPTION

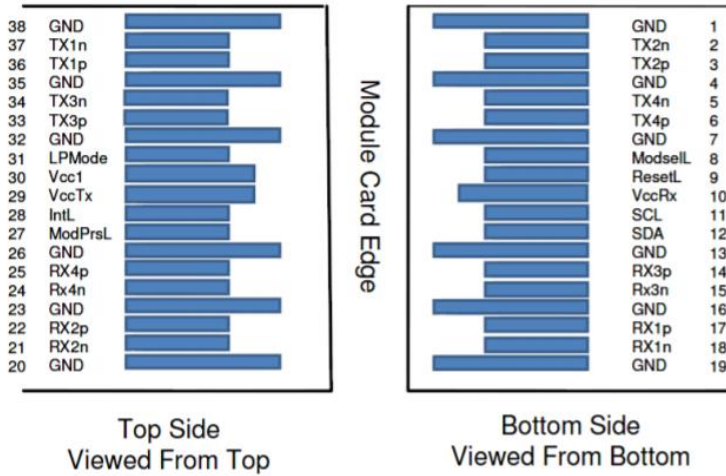

PIN	LOGIC	SYMBOL	DESCRIPTION	PLUG SEQUENCE	NOTE
1		GND	Ground	1	Note 1
2	CML-I	Tx2n	Transmitter Inverted Data Input	3	
3	CML-I	Tx2p	Transmitter Non-Inverted Data Input	3	
4		GND	Ground	1	Note 1
5	CML-I	Tx4n	Transmitter Inverted Data Input	3	
6	CML-I	Tx4p	Transmitter Non-Inverted Data Input	3	
7		GND	Ground	1	Note 1
8	LVTTL-I	ModSelL	Module Select	3	
9	LVTTL-I	ResetL	Module Reset	3	
10		Vcc Rx	+3.3V Power Supply Receiver	2	Note 2
11	LVCMOS-I/O	SCL	2-wire serial interface clock	3	
12	LVCMOS-I/O	SDA	2-wire serial interface data	3	
13		GND	Ground	1	Note 2
14	CML-O	Rx3p	Receiver Non- Inverted Data Output	3	
15	CML-O	Rx3n	Receiver Inverted Data Output	3	
16		GND	Ground	1	Note 1
17	CML-O	Rx1p	Receiver Non- Inverted Data Output	3	



PIN	LOGIC	SYMBOL	DESCRIPTION	PLUG SEQUENCE	NOTE
18	CML-O	Rx1n	Receiver Inverted Data Output	3	
19		GND	Ground	1	Note 1
20		GND	Ground	1	Note 1
21	CML-O	Rx2n	Receiver Inverted Data Output	3	
22	CML-O	Rx2P	Receiver Non- Inverted Data Output	3	
23		GND	Ground	1	Note 1
24	CML-O	Rx4n	Receiver Inverted Data Output	3	
25	CML-O	Rx4p	Receiver Non- Inverted Data Output	3	
26		GND	Ground	1	Note 1
27	LVTTL-O	ModPrsL	Module Present	3	
28	LVTTL-O	IntL	Interrupt	3	
29	LVC MOS-I/O	Vcc Tx	+3.3V Power Supply transmitter	2	Note 2
30		Vcc1	+3.3V Power Supply	2	Note 2
31	LVTTL-I	LPMODE	Low Power Mode	3	
32		GND	Ground	1	Note 1
33	CML-I	Tx3p	Transmitter Non- Inverted Data Input	3	
34	CML-I	Tx3n	Transmitter Inverted Data Input	3	
35		GND	Ground	1	Note 1
36	CML-I	Tx1p	Transmitter Non- Inverted Data Input	3	
37	CML-I	Tx1n	Transmitter Inverted Data Input	3	
38		GND	Ground	1	Note 1

Note 1: GND is the symbol for signal and supply (power) common for the QSFP module. All are common within the QSFP+ module and all module voltages are referenced to this potential unless otherwise noted. Connect these directly to the host board signal-common ground plane.

Note 2: Vcc Rx, Vcc1 and Vcc Tx are the receiver and transmitter power supplies and shall be applied concurrently. Requirements defined for the host side of the Host Edge Card Connector are listed in Table. Recommended host board power supply filtering is shown in Host board power supply circuit. Vcc Rx Vcc1 and Vcc Tx may be internally connected within the QSFP+ module in any combination. The connector pins are each rated for a maximum current of 500 mA.



HOST BOARD POWER SUPPLY CIRCUIT

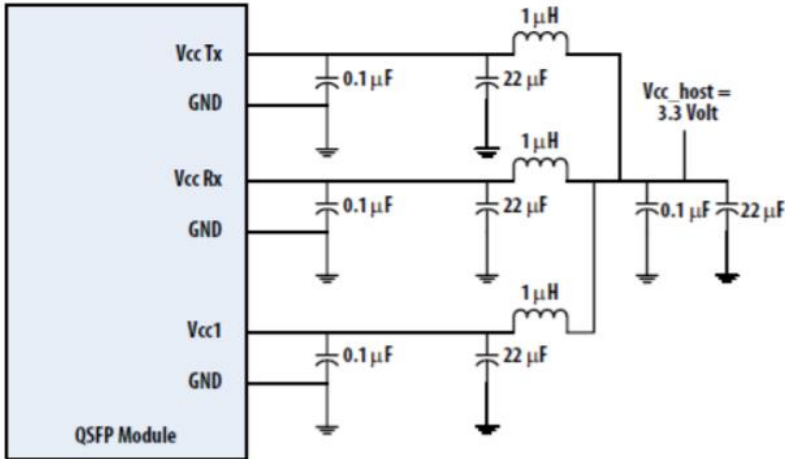

RECOMMENDED INTERFACE CIRCUIT

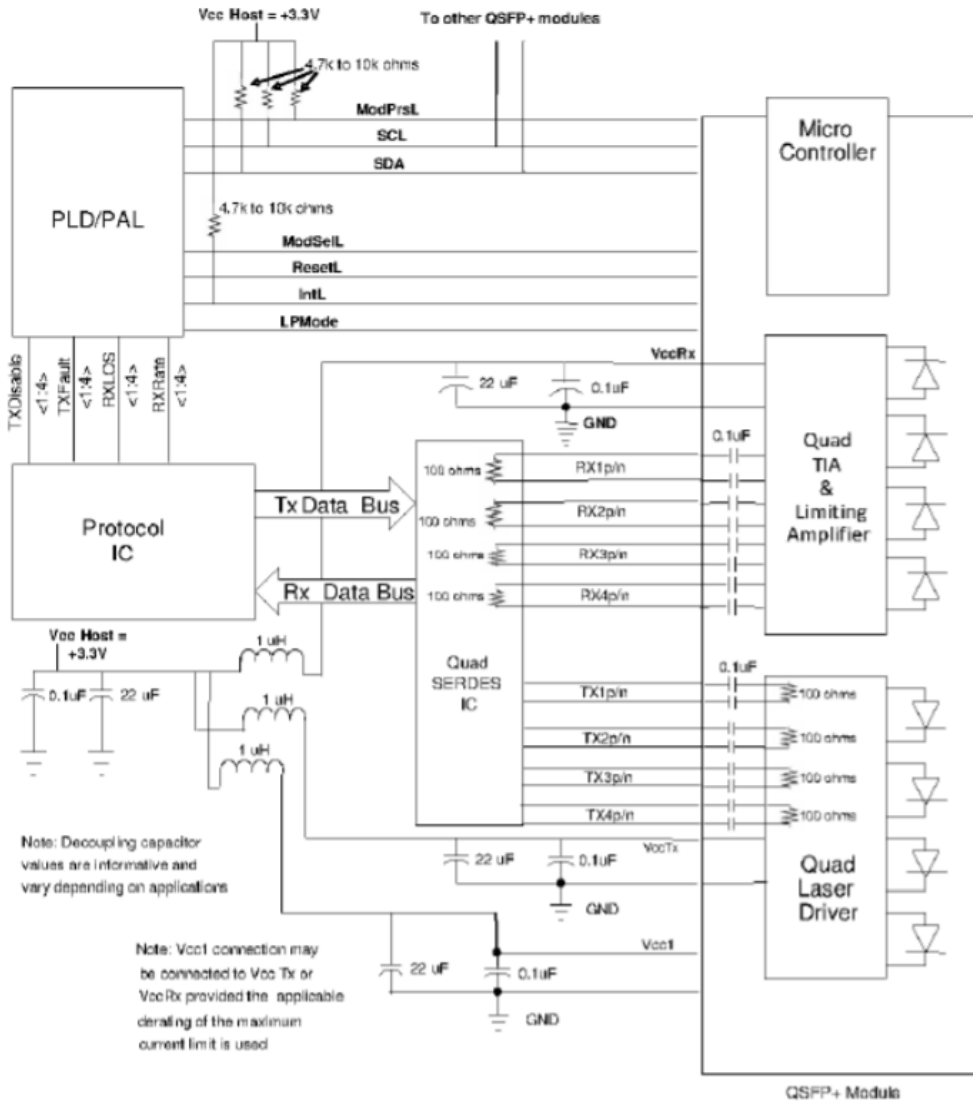

Note: Decoupling capacitor values are informative and vary depending on applications

Note: Vcc1 connection may be connected to Vcc Tx or Vcc Rx provided the applicable derating of the maximum current limit is used



DIMENSIONS (unit: mm)

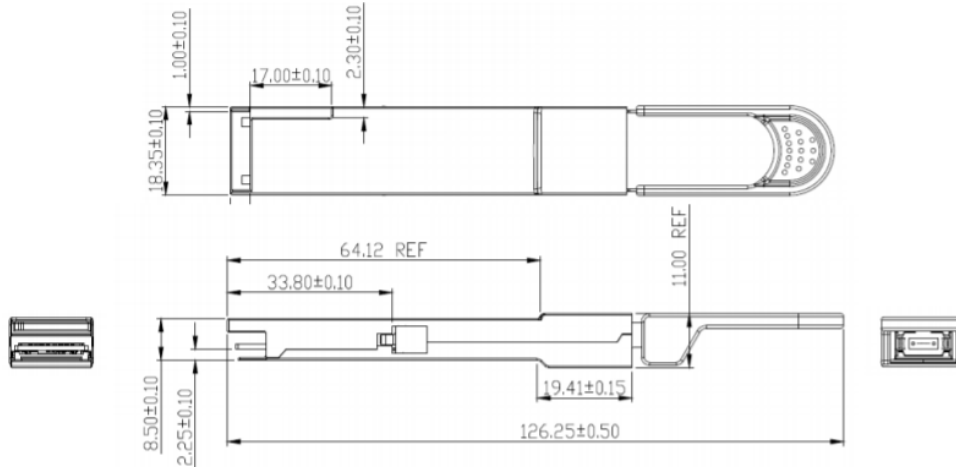

MEMORY MAP

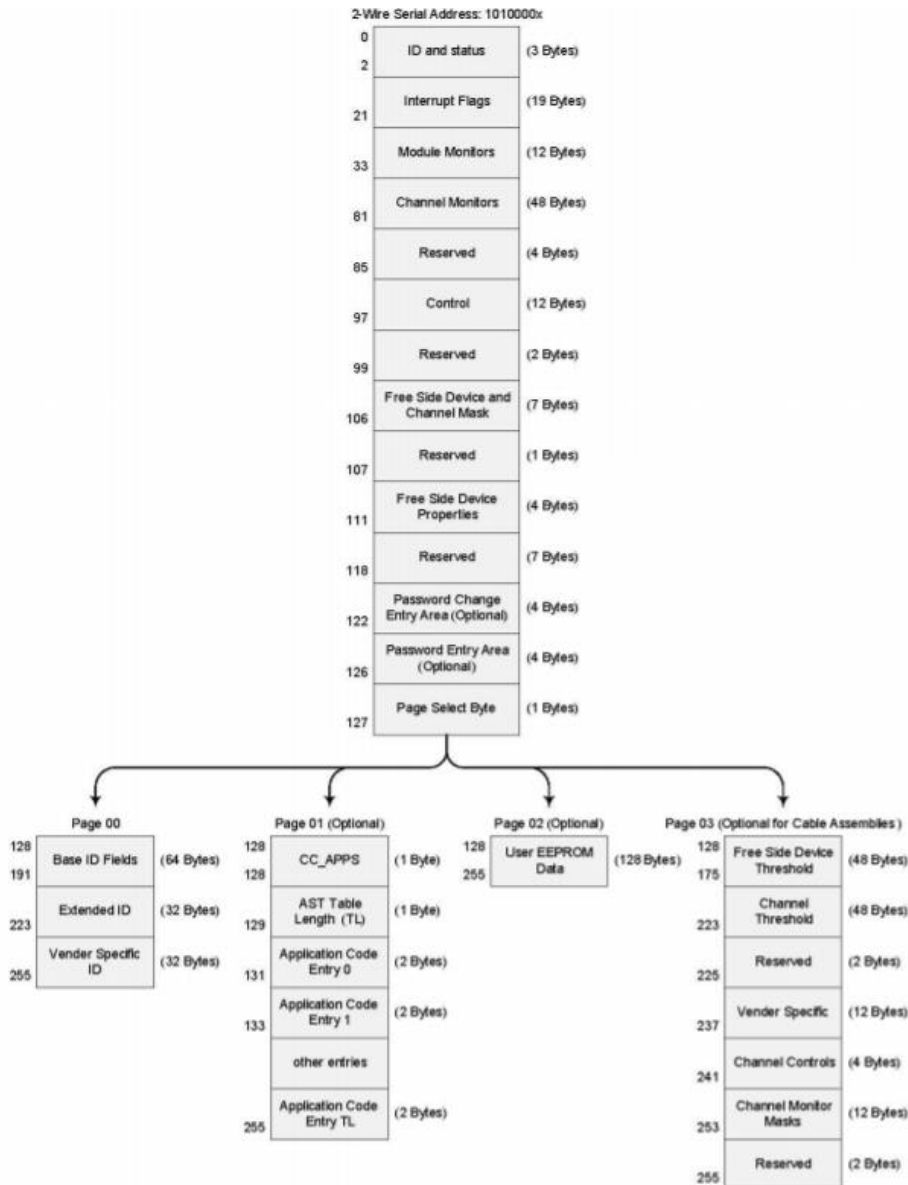



EYE SAFETY MARK

The multimode transceiver is a class 1M laser product. It complies with EN 60825-1:2007 and FDA 21 CFR 1040.10 and 1040.11. In order to meet laser safety requirements, the transceiver shall be operated within the Absolute Maximum Ratings.

Required Mark

**Class 1M Laser Product
Complies with
21 CFR 1040.10 and 1040.11**

[CAUTION]

All adjustments have been done at the factory before the shipment of the devices. No maintenance and user serviceable part is required. Tampering with and modifying the performance of the device will result in voided product warranty.

Use of controls or adjustment or performance of procedures other than those specified herein may result in hazardous radiation exposure.

Complies with FDA performance standards for laser products except for deviations pursuant to Laser Notice No. 50.

Note: The specifications subject to change without notice.